

FLENDER CLAMPING ELEMENTS
CATALOG **FLE 10.8**
EDITION 2023.1 EN



CLAMPING ELEMENTS
FASTEX

CLAMPING ELEMENTS



Catalog FLE 10.8 Edition 2023 EN

Introduction

FASTEX I internal clamping sets

FASTEX E external clamping sets

Appendix

E

1

2

A

The products and systems described in this catalog are manufactured/distributed under application of a certified quality management system in accordance with DIN EN ISO 9001 (Certified Registration No. 01 100 000708). The certificate is recognized by all IQNet countries.

FLE 10 CATALOG GROUP



Product catalog FLE 10.1
FLEX-C10001-00-7600
Torsionally Rigid Couplings



Product catalog FLE 10.3
FLEX-C10003-00-7600
Highly Flexible Couplings



Product catalog FLE 10.2
FLEX-C10001-00-7600
Flexible Couplings



Product catalog FLE 10.4
FLEX-C10004-00-7600
Fluid Couplings

For further coupling catalogs, see page A/2

FLENDER COUPLINGS
CATALOG **FLE 10.5**
EDITION EN

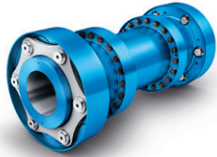

HIGH PERFORMANCE COUPLINGS
ARPEX

flender.com

FLENDER

Product catalog FLE 10.5
FLEX-C10120-00-7600
High Performance Couplings

FLENDER-COUPLINGS
CATALOG **FLE 10.7**
EDITION EN



SAFETY COUPLINGS
ARPEX

flender.com

FLENDER

Product catalog FLE 10.7
FLEX-C10122-00-7600
Safety couplings

FLENDER COUPLINGS
CATALOG **FLE 10.6**
EDITION EN

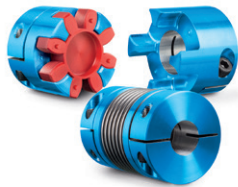

BACKLASH-FREE COUPLINGS
SIPEX AND BIPEX-S

flender.com

FLENDER

Product catalog FLE 10.6
FLEX-C10121-00-7600
Backlash-free couplings

FLENDER CLAMPING ELEMENTS
CATALOG **FLE 10.8**
EDITION EN



CLAMPING ELEMENTS
FASTEX

flender.com

FLENDER

Product catalog FLE 10.8
FLEX-C10152-00
Clamping elements

GENERAL

E

Shaft-hub connections play an important role in mechanical engineering. Countless variations exist to ensure the safe transmission of torques. They are split into the following categories:

- interlocking connections
- firmly bonded connections
- frictionally engaged connections

FASTEX clamping elements are frictionally engaged connections that enable quick installation and removal thanks to their simple design.

Compared to conventional key connections, clamping elements have a significantly higher power density and are capable of a safer and more reliable transmission of torques, axial forces and bending moments.

As a result, the clamping elements and components to be connection can be more compact, permitting the use of less materials and simpler processing through the use of shafts without grooves, which in turn improves efficiency.

Depending on the respective application, the FASTEX clamping elements can be selected as either an interior or exterior clamping set. This allows the range of Flender couplings to benefit from an additional quick and effective connection option for shafts and hubs.

The primary function of clamping elements is to push one or more conical thrust rings onto a conical clamping hub using clamping screws. The resulting radial extension produces radial forces inwards and outwards on the contact surfaces and ensures the frictional connection between the parts involved in the transmission of torques and forces.

Benefits

- Clearance free, easy to adjust
- High power density
- Easy to install in Flender couplings
- Compact design, high concentricity
- Low surface pressure
- Transmission of torques, axial and transverse forces, bending moments
- Quick installation and removal
- Detachable connection, reusable
- Perfectly suited for reversing operation

Application

Exemplary applications for FASTEX clamping elements

- | | | | |
|------------------|--------------------------|--------------------------|---------------------|
| • Chain drives | • Mills | • Crushers | • Paper industry |
| • Belt drives | • Forklifts | • Macerators | • Reactors |
| • Elevators | • Mixers | • Packaging machines | • Marine technology |
| • Cranes | • Pumps | • Cable winding machines | • Textile plants |
| • Sawmills | • Agricultural machinery | • Paternoster elevators | • Fans |
| • Conveyor belts | • Compressors | • Industrial furnaces | • Dryers |
| • Mining | • Presses | • Extruders | • Printing machines |

Design and configurations

FASTEX internal clamping sets

The internal clamping sets consist of a conical inner ring (clamping hub) and a conical outer ring (clamping bush).

One or several conical outer rings are pushed onto a conical inner ring using clamping screws. The resulting radial extension produces radial forces inwards and outwards on the contact surfaces. This ensures the frictional connection between the parts involved in the transmission of torques and forces.

The internal clamping sets are therefore located in the power train.

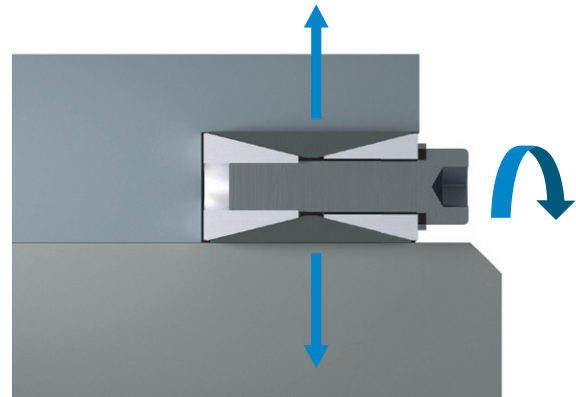

FASTEX external clamping sets

The external clamping sets consist of a conical inner ring (clamping hub) and a conical outer ring (clamping bush).

With the external clamping sets, one or several conical outer rings are also pushed onto a conical inner ring using clamping screws. The resulting radial extension produces radial forces inwards on the contact surfaces. This ensures the frictional connection between the parts involved in the transmission of torques and forces.

The external clamping sets are therefore not directly located in the power train, but instead transmit the forces from outside to the shaft via the hub.

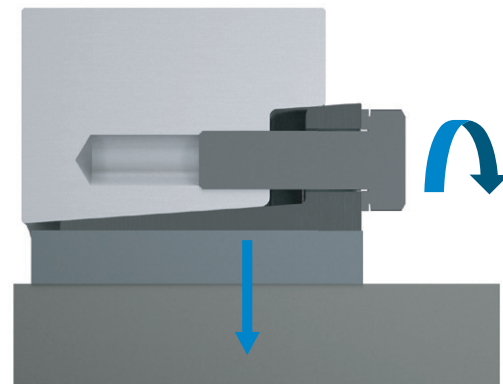

TECHNICAL INFORMATION

E

Required clamping element properties

In principle, clamping elements are selected according to the required torque and axial force transmission in a predefined assembly space. In addition, they are classified according to the following properties:

- Internal clamping set: The clamping set is located in the power train between the shaft and hub
- External clamping set: The clamping set is position externally on the hub and is not directly located in the power train

Following this, a distinction is made regarding the centering properties:

- Self-centering clamping sets: The shaft and hub are centric to one another through the clamping set
- Non-self-centering clamping sets: The shaft and hub are not centric to one another through the clamping set

Once the centering properties have been selected, the classification takes place according to the hub displacement during assembly:

- Axial hub displacement is permissible during assembly
- Axial hub displacement is not permissible during assembly

You can find a summary of the key properties and dimensions in the overview on [pages E/8 and E/9](#), an in Sections 1 and 2 after [page 1/1](#).

Calculating the hub and hollow shaft wall thickness

The walls of the hub and hollow shaft need to be adequately thick for the use of clamping elements. The corresponding calculation bases for the minimal hub external diameter and the required

You can find the hollow shaft diameter in the section "Clamping element design" [page E/11](#).

Clamping element under bending load

Bending loads lead to increased tension on the loaded side of the clamping element. By contrast, the tension on the unloaded side of the clamping element reduces.

This results in edge pressure on the loaded sides and a reduced surface pressure on the unloaded side of the clamping element. Information on the permitted limit bending moments can be requested from Flender GmbH.

Fit classification and surface roughness

The recommended fit classification and required surface roughness for the shaft-hub connections can be found of the corresponding pages for the designs and in the overview on [pages E/8 and E/9](#).

Note: If the fitting clearance listed in the catalogue is increased, the transmissible torque will reduce. The fit classifications stated in the catalogue are expressly recommended.

Use of the clamping elements in potentially explosive atmospheres

The component supplier is responsible for the system design of the clamping element and all related components in compliance with the relevant directives.

The labelling and information on operating conditions can be found in the overriding operating instructions provided by the component supplier.

Concentricity

The concentricity of the self-centering internal clamping sets is between 0.02 mm and 0.10 mm. The listed measurements solely serve as design aids for the slotted versions of the self-centering internal clamping set and cannot be replicated.

If high requirements apply in terms of balance, the entire assembly should be balanced.

Peripheral speeds

The following maximum peripheral speeds are permitted:

- Internal clamping sets from the IC and IN series: ≤ 30 m/s
- External clamping sets from the EC210 series: ≤ 40 m/s
- External clamping sets from the EC220 series: ≤ 30 m/s

In the case of higher peripheral speeds, please get in touch with Flender GmbH.

Temperature range

The clamping elements can be used in a temperature range from -20 °C to $+160$ °C. In the case of deviating temperatures, please get in touch with Flender GmbH.

CLAMPING ELEMENTS FASTEX

E

Internal clamping sets

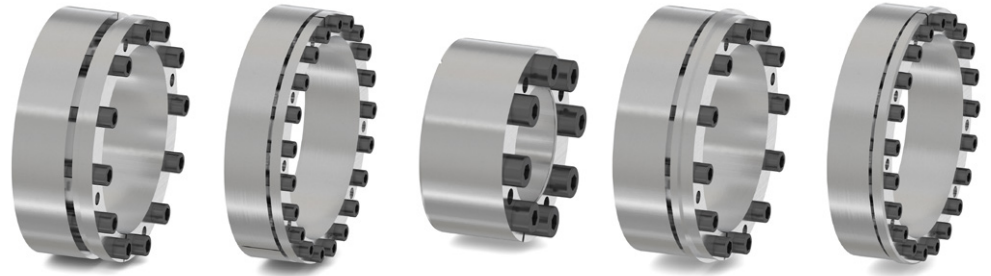

IC110

IC120

IC130

IC210

IC220

Shaft diameter	19 ... 220 mm	18 ... 400 mm	5 ... 50 mm	19 ... 330 mm	18 ... 400 mm
Transmissible torque T_{CL}	530 ... 82 000 Nm	370 ... 487 000 Nm	5 ... 1 900 Nm	300 ... 59 000 Nm	290 ... 342 000 Nm
Maximal peripheral speed	≤ 30 m/s	≤ 30 m/s	≤ 30 m/s	≤ 30 m/s	≤ 30 m/s
Self-centering	■	■	■	■	■
With axial displacement of the hub	■	■	■	-	-
Shaft dimensional tolerance	h8	h8	h8	h8	h8
Hub dimensional tolerance	H8	H8	H8	H8	H8
Shaft surface quality	$R_a \leq 3,2 \mu\text{m}$	$R_a \leq 3,2 \mu\text{m}$	$R_a \leq 3,2 \mu\text{m}$	$R_a \leq 3,2 \mu\text{m}$	$R_a \leq 3,2 \mu\text{m}$
Hub surface quality	$R_a \leq 3,2 \mu\text{m}$	$R_a \leq 3,2 \mu\text{m}$	$R_a \leq 3,2 \mu\text{m}$	$R_a \leq 3,2 \mu\text{m}$	$R_a \leq 3,2 \mu\text{m}$

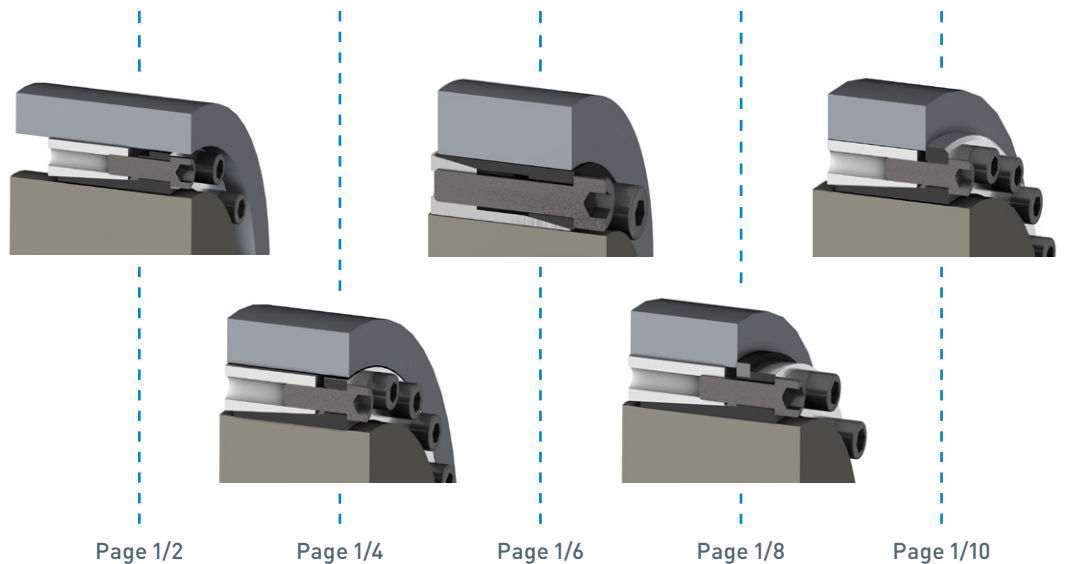

Page 1/2

Page 1/4

Page 1/6

Page 1/8

Page 1/10

External clamping sets



IC230

IC240

IC250

IN110

IN220

EC210

EC220

14 ... 50 mm

24 ... 600 mm

6 ... 130 mm

6 ... 500 mm

17 ... 520 mm

16 ... 500 mm

14 ... 500 mm

287 ... 1 796 Nm

730 ... 164 000 Nm

11 ... 25 000 Nm

2 ... 278 000 Nm

260 ... 861 000 Nm

70 ... 1 915 000 Nm

28 ... 1 460 000 Nm

≤30 m/s

≤30 m/s

≤30 m/s

≤30 m/s

≤30 m/s

≤40 m/s

≤30 m/s



h8

h8

h8, j7, k6, m6

h6 (D1 ≤ 38 mm)
h8 (D1 > 38 mm)

k11 - h11

h6 (DS ≤ 160 mm)
g6 (DS > 160 mm)

j6 (DS 10 - 30 mm)
h6 (DS 31 - 50 mm)
g6 (DS 51 - 80 mm)
g6 (DS 81 - 500 mm)

H8

H8

H7

H7 (D1 ≤ 38 mm)
H8 (D1 > 38 mm)

N11 - H11

H7

H6 (DS 10 - 30 mm)
H6 (DS 31 - 50 mm)
H6 (DS 51 - 80 mm)
H7 (DS 81 - 500 mm)

Ra ≤ 3,2 µm

Ra ≤ 3,2 µm

Ra ≤ 3,2 µm

Ra ≤ 1 µm

Ra ≤ 3,2 µm

Ra ≤ 3,2 µm

Ra ≤ 3,2 µm

Ra ≤ 3,2 µm

Ra ≤ 3,2 µm

Ra ≤ 3,2 µm

Ra ≤ 1 µm

Ra ≤ 3,2 µm

Ra ≤ 3,2 µm

Ra ≤ 3,2 µm

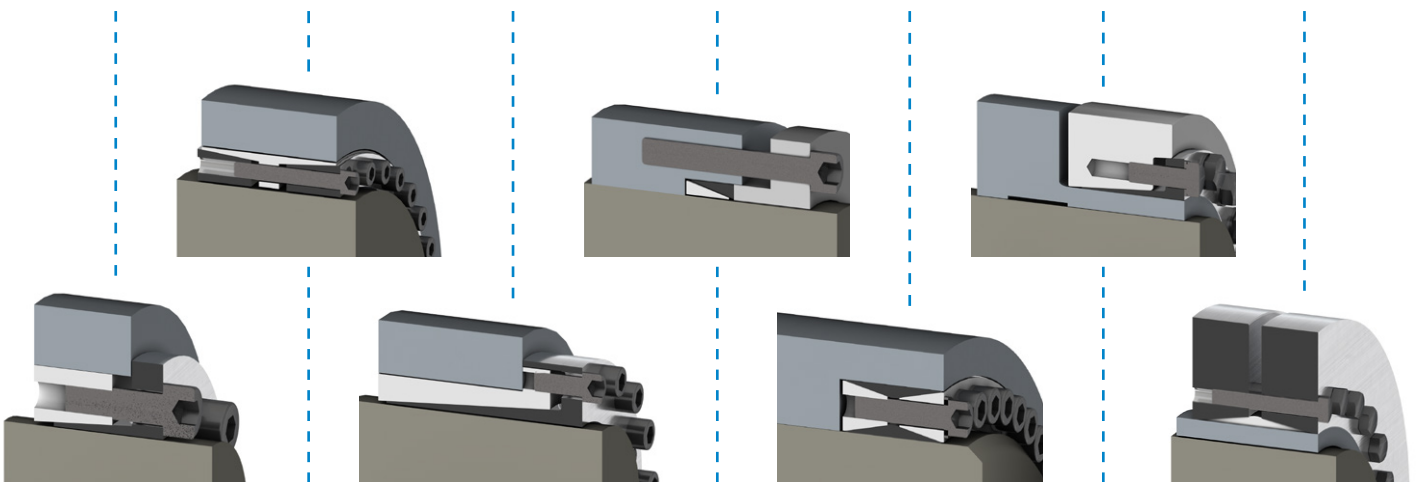

Page 1/12

Page 1/14

Page 1/16

Page 1/18

Page 1/22

Page 2/2

Page 2/8

GENERAL

E

Key to symbols

Name	Symbols	Unit	Explanation
Tightening torque	T_A	Nm	Tightening torque of the cylinder screws
Transmissible torque	T_{CL}	Nm	Transmissible torque at tightening torque T_A
Rated torque	T_N	Nm	Rated torque of the machine
Peak torque	T_S	Nm	Peak rated torque of the machine achieved
Transmissible axial force	F_a	kN	Transmissible axial force of the clamping element at tightening torque T_A
Axial force of the machine	F_N	kN	Axial forces achieved by the machine when operated at rated load
Maximum axial force	F_S	kN	Maximum axial forces achieved by the machine
Inner diameter	D1	mm	Inner diameter of the clamping element
Outer diameter	D2	mm	Outer diameter of the clamping element
Hub external diameter	D_N	mm	
Inner diameter of the hollow shaft	D_{iW}	mm	
Hub length	L	mm	
Clamping element length	L1	mm	
Clamping element length	L2	mm	
Clamping element length	L3	mm	
Adjustment value	x		
Hub formers	C		
Clamping element/hub surface pressure	P_{SN}	N/mm ²	Surface pressure arising between the clamping element and hub
Clamping element/shaft surface pressure	P_{SW}	N/mm ²	Surface pressure arising between the clamping element and shaft
Clamping element/hollow shaft surface pressure	P_{SH}	N/mm ²	Surface pressure arising between the clamping element and hollow shaft
Yield strength of the hub material	$\sigma_{N0,2}$	N/mm ²	
Yield strength of the shaft material	$\sigma_{W0,2}$	N/mm ²	
Tangential load	σ_{iN}	N/mm ²	Tangential load of the hub's inner diameter
Tangential stress	σ_{iW}	N/mm ²	Tangential stress on the inner diameter of the hollow shaft
Setting force	P_0	kN	Setting force
Clamping force	P_S	kN	Clamping force
Total force	P_A	kN	Total force

Clamping element design

Transmissible torque T_{CL}

$$T_{CL} \geq \sqrt{T_S^2 + \left(F_N \cdot \frac{D1}{2}\right)^2}$$

The transmissible torque T_{CL} must always exceed the highest torque peak T_S . In addition, the axial forces F_N that arise must be taken into account.

Transmissible axial force F_a

$$F_a = 2 \cdot \frac{T_{CL}}{D1}$$

The maximum transmissible force F_a listed in the tables must be correspondingly reduced in the event of additional torque transmission.

Calculating the outer diameter of the hub D_N

$$D_N \geq D2 \cdot x$$

$$x = \sqrt{\frac{\sigma_{N0,2} + (C \cdot P_{SN})}{\sigma_{N0,2} - (C \cdot P_{SN})}}$$

The required hub outer diameter D_N depends on the hub geometry, the yield strength of the hub material and the surface pressure between the clamping element and the hub. The adjustment value x can be found in the table on [page E/12](#).

Adjustment values that are not included in the table can be calculated using the formula on the left.

Calculating the tangential stress on the inner diameter of the hub σ_{tiN}

$$\sigma_{tiN} \approx P_{SN} \cdot \frac{1 + \left(\frac{D2}{D_N}\right)^2}{1 - \left(\frac{D2}{D_N}\right)^2} \cdot C$$

The tangential stress σ_{tiN} on the inner diameter of the hub depends on the surface pressure between the clamping element and hub, the ratio between the outer diameter of the clamping element and the hub, and the hub geometry.

Calculating the required inner diameter of the hollow shaft D_{iW}

$$D_{iW} \leq D1 \cdot \sqrt{\frac{\sigma_{W0,2} - 2 \cdot P_{SW} \cdot 0,8}{\sigma_{W0,2}}}$$

The required inner diameter of the hollow shaft D_{iW} depends on the yield strength of the hollow shaft and the surface pressure between the clamping element and shaft.

Calculating the tangential stress on the inner diameter of the hollow shaft σ_{tiW}

$$\sigma_{tiW} \approx \frac{2 \cdot P_{SW}}{\left(\frac{D_{iW}}{D_N}\right)^2 - 1}$$

The tangential stress σ_{tiW} on the inner diameter of the hollow shaft depends on the surface pressure between the clamping element and shaft, and the ratio between the outer diameter of the clamping element and the hollow shaft.

Recommended safety factors

$$T_{CL} \geq 1,5 \cdot T_S$$

$$F_a \geq 1,5 \cdot F_S$$

$$T_{CL} \geq 2 \cdot T_N$$

$$F_a \geq 2 \cdot F_N$$

A safety factor of at least 1.5 is recommended between the peak torque of the machine and the transmissible torque as well as between the maximum achieved axial force and the transmissible axial force. A safety factor of 2 is recommended for the rated load range.

GENERAL

E

Determining adjustment value x in order to calculate the outer diameter of the hub D_N

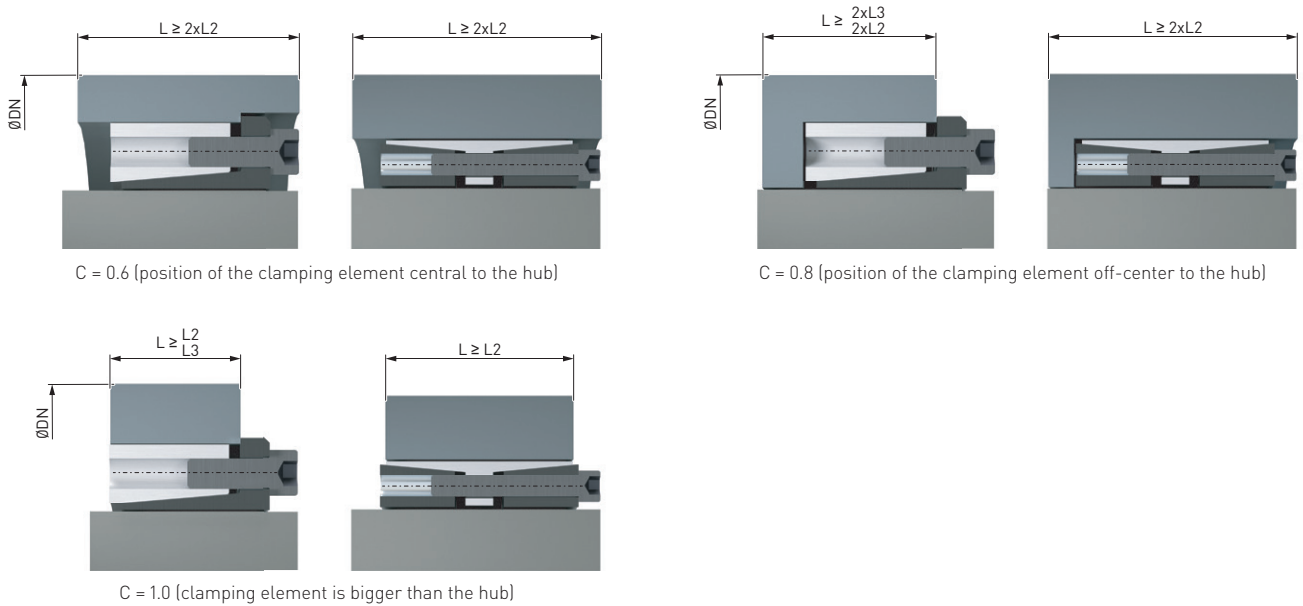

Adjustment value x												
Surface pressure P_{SN} N/mm ²	Hub shape	Average yield strength of the hub material ¹⁾ $\sigma_{No,2}$ in N/mm ²										
		150	180	200	220	250	270	300	350	400	450	600
		Hub material										Quenched and tempered steel
		GJL 200	GJL 250 GE 200	GJL 300 GJMB-350	GE 240	GJS 400-15 GE 260 AW-2007	E295 C 35	GJS 500-7 GE 300	GJS 600-3 C 45	GJS 700-2 C 60		
60	C = 0.6	1.28	1.22	1.20	1.18	1.16	1.14	1.13	1.11	1.09	1.08	1.06
	C = 0.8	1.39	1.31	1.28	1.25	1.21	1.20	1.18	1.15	1.13	1.11	1.08
	C = 1.0	1.53	1.41	1.36	1.32	1.28	1.25	1.22	1.19	1.16	1.14	1.11
65	C = 0.6	1.30	1.25	1.22	1.20	1.17	1.16	1.14	1.12	1.10	1.09	1.07
	C = 0.8	1.44	1.35	1.30	1.27	1.24	1.22	1.19	1.16	1.14	1.12	1.09
	C = 1.0	1.59	1.46	1.40	1.36	1.30	1.28	1.25	1.21	1.18	1.16	1.11
70	C = 0.6	1.33	1.27	1.24	1.21	1.18	1.17	1.15	1.13	1.11	1.10	1.07
	C = 0.8	1.48	1.38	1.33	1.30	1.26	1.23	1.21	1.18	1.15	1.13	1.10
	C = 1.0	1.66	1.51	1.44	1.39	1.33	1.30	1.27	1.22	1.19	1.17	1.12
75	C = 0.6	1.36	1.29	1.26	1.23	1.20	1.18	1.16	1.14	1.12	1.11	1.08
	C = 0.8	1.53	1.41	1.36	1.32	1.28	1.25	1.22	1.19	1.16	1.14	1.11
	C = 1.0	1.73	1.56	1.48	1.43	1.36	1.33	1.29	1.24	1.21	1.18	1.13
80	C = 0.6	1.39	1.31	1.28	1.25	1.21	1.20	1.18	1.15	1.13	1.11	1.08
	C = 0.8	1.58	1.45	1.39	1.35	1.30	1.27	1.24	1.20	1.18	1.15	1.11
	C = 1.0	1.81	1.61	1.53	1.46	1.39	1.36	1.31	1.26	1.22	1.20	1.14
85	C = 0.6	1.42	1.34	1.30	1.27	1.23	1.21	1.19	1.16	1.14	1.12	1.09
	C = 0.8	1.63	1.49	1.42	1.38	1.32	1.29	1.26	1.22	1.19	1.16	1.12
	C = 1.0	1.90	1.67	1.57	1.50	1.42	1.39	1.34	1.28	1.24	1.21	1.15
90	C = 0.6	1.46	1.36	1.32	1.28	1.25	1.22	1.20	1.17	1.15	1.13	1.09
	C = 0.8	1.69	1.53	1.46	1.40	1.34	1.31	1.28	1.23	1.20	1.18	1.13
	C = 1.0	2.00	1.73	1.62	1.54	1.46	1.41	1.36	1.30	1.26	1.22	1.16

¹⁾ Exact stiffness value depending on the diameter stipulated in the manufacturer information

Adjustment value x												
Surface pressure P_{SN} N/mm ²	Hub shape	Average yield strenght of the hub material ¹⁾ $\sigma_{No.2}$ in N/mm ²										
		150	180	200	220	250	270	300	350	400	450	600
		Hub material										
		GJL 200	GJL 250 GE 200	GJL 300 GJMB-350	GE 240	GJS 400-15 GE 260 AW-2007	E295 C 35	GJS 500-7 GE 300	GJS 600-3 C 45	GJS 700-2 C 60	Quenched and tem- pered steel	Quenched and tem- pered steel
95	C = 0.6	1.49	1.39	1.34	1.30	1.26	1.24	1.21	1.18	1.15	1.14	1.10
	C = 0.8	1.75	1.57	1.49	1.43	1.37	1.34	1.30	1.25	1.21	1.19	1.14
	C = 1.0	2.11	1.80	1.68	1.59	1.49	1.44	1.39	1.32	1.27	1.24	1.17
100	C = 0.6	1.53	1.41	1.36	1.32	1.28	1.25	1.22	1.19	1.16	1.14	1.11
	C = 0.8	1.81	1.61	1.53	1.46	1.39	1.36	1.31	1.26	1.22	1.20	1.14
	C = 1.0	2.24	1.87	1.73	1.63	1.53	1.48	1.41	1.34	1.29	1.25	1.18
105	C = 0.6	1.56	1.44	1.39	1.34	1.29	1.27	1.24	1.20	1.17	1.15	1.11
	C = 0.8	1.88	1.66	1.56	1.50	1.42	1.38	1.33	1.28	1.24	1.21	1.15
	C = 1.0	2.38	1.95	1.79	1.68	1.56	1.51	1.44	1.36	1.31	1.27	1.19
110	C = 0.6	1.60	1.47	1.41	1.36	1.31	1.28	1.25	1.21	1.18	1.16	1.12
	C = 0.8	1.96	1.71	1.60	1.53	1.44	1.40	1.35	1.29	1.25	1.22	1.16
	C = 1.0	2.55	2.04	1.86	1.73	1.60	1.54	1.47	1.38	1.33	1.28	1.20
115	C = 0.6	1.64	1.50	1.43	1.38	1.33	1.30	1.26	1.22	1.19	1.17	1.12
	C = 0.8	2.04	1.76	1.64	1.56	1.47	1.43	1.37	1.31	1.26	1.23	1.17
	C = 1.0	2.75	2.13	1.93	1.79	1.64	1.58	1.50	1.41	1.34	1.30	1.21
120	C = 0.6	1.69	1.53	1.46	1.40	1.34	1.31	1.28	1.23	1.20	1.18	1.13
	C = 0.8	2.13	1.81	1.69	1.60	1.50	1.45	1.39	1.33	1.28	1.24	1.18
	C = 1.0	3.00	2.24	2.00	1.84	1.69	1.61	1.53	1.43	1.36	1.31	1.22
125	C = 0.6	1.73	1.56	1.48	1.43	1.36	1.33	1.29	1.24	1.21	1.18	1.13
	C = 0.8	2.24	1.87	1.73	1.63	1.53	1.48	1.41	1.34	1.29	1.25	1.18
	C = 1.0	3.32	2.35	2.08	1.91	1.73	1.65	1.56	1.45	1.38	1.33	1.24
130	C = 0.6	1.78	1.59	1.51	1.45	1.38	1.35	1.30	1.25	1.22	1.19	1.14
	C = 0.8	2.35	1.93	1.78	1.67	1.56	1.50	1.44	1.36	1.30	1.27	1.19
	C = 1.0	3.74	2.49	2.17	1.97	1.78	1.69	1.59	1.48	1.40	1.35	1.25
135	C = 0.6	1.83	1.62	1.54	1.47	1.40	1.36	1.32	1.27	1.23	1.20	1.15
	C = 0.8	2.48	2.00	1.83	1.71	1.59	1.53	1.46	1.38	1.32	1.28	1.20
	C = 1.0	4.36	2.65	2.27	2.04	1.83	1.73	1.62	1.50	1.42	1.36	1.26
140	C = 0.6	1.88	1.66	1.56	1.50	1.42	1.38	1.33	1.28	1.24	1.21	1.15
	C = 0.8	2.63	2.07	1.88	1.75	1.62	1.55	1.48	1.39	1.33	1.29	1.21
	C = 1.0	5.39	2.83	2.38	2.12	1.88	1.78	1.66	1.53	1.44	1.38	1.27
145	C = 0.6	1.94	1.69	1.59	1.52	1.44	1.40	1.35	1.29	1.25	1.22	1.16
	C = 0.8	2.80	2.15	1.94	1.80	1.65	1.58	1.50	1.41	1.35	1.30	1.22
	C = 1.0	7.68	3.05	2.50	2.21	1.94	1.82	1.69	1.55	1.46	1.40	1.28
150	C = 0.6	2.00	1.73	1.62	1.54	1.46	1.41	1.36	1.30	1.26	1.22	1.16
	C = 0.8	3.00	2.24	2.00	1.84	1.69	1.61	1.53	1.43	1.36	1.31	1.22
	C = 1.0	-	3.32	2.65	2.30	2.00	1.87	1.73	1.58	1.48	1.41	1.29
155	C = 0.6	2.06	1.77	1.65	1.57	1.48	1.43	1.38	1.31	1.27	1.23	1.17
	C = 0.8	3.25	2.33	2.06	1.89	1.72	1.64	1.55	1.45	1.38	1.33	1.23
	C = 1.0	-	3.66	2.81	2.40	2.06	1.92	1.77	1.61	1.51	1.43	1.30
160	C = 0.6	2.13	1.81	1.69	1.60	1.50	1.45	1.39	1.33	1.28	1.24	1.18
	C = 0.8	3.55	2.43	2.13	1.94	1.76	1.67	1.58	1.47	1.39	1.34	1.24
	C = 1.0	-	4.12	3.00	2.52	2.13	1.98	1.81	1.64	1.53	1.45	1.31
165	C = 0.6	2.21	1.86	1.72	1.62	1.52	1.47	1.41	1.34	1.29	1.25	1.18
	C = 0.8	3.96	2.55	2.21	2.00	1.80	1.71	1.60	1.49	1.41	1.35	1.25
	C = 1.0	-	4.80	3.23	2.65	2.21	2.04	1.86	1.67	1.55	1.47	1.33

¹⁾ Exact stiffness value depending on the diameter stipulated in the manufacturer information

CLAMPING ELEMENTS

FASTEX INTERNAL CLAMPING SETS



FASTEX IC110	self-centering with axial hub displacement	1/2
FASTEX IC120	self-centering with axial hub displacement	1/4
FASTEX IC130	self-centering with axial hub displacement	1/6
FASTEX IC210	self-centering without axial hub displacement	1/8
FASTEX IC220	self-centering without axial hub displacement	1/10
FASTEX IC230	self-centering without axial hub displacement	1/12
FASTEX IC240	self-centering without axial hub displacement	1/14
FASTEX IC250	self-centering without axial hub displacement	1/16
FASTEX IN110	non-self-centering with axial hub displacement, for shaft diameters from 6 to 80 mm	1/18
FASTEX IN110	non-self-centering with axial hub displacement, for shaft diameters from 85 to 500 mm	1/20
FASTEX IN220	non-self-centering without axial hub displacement	1/22

FASTEX IC110

self-centering with axial hub displacement

1

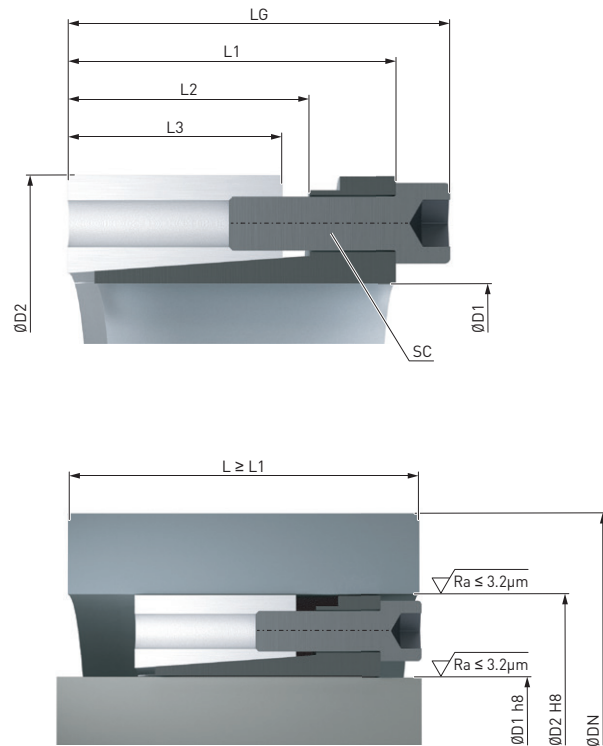
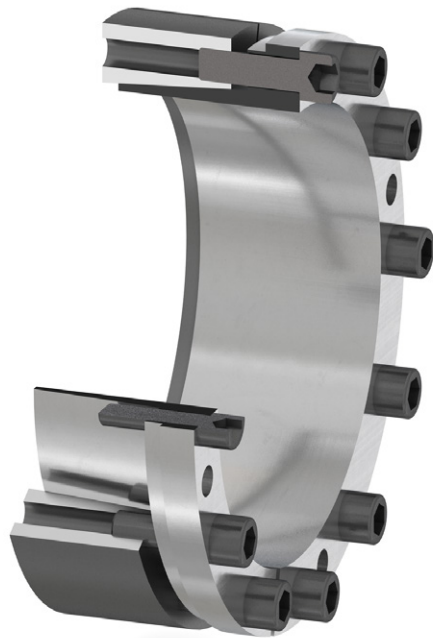

Hub exemplary applications

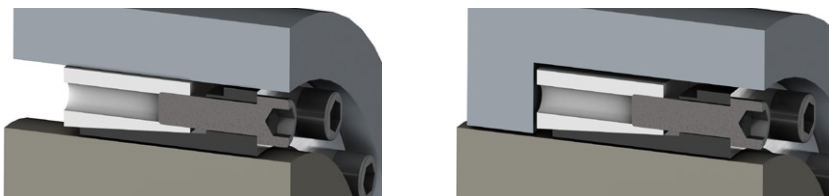

Notes

- Temperature range -20 to 160 °C
- Recommended shaft tolerances h8 with a surface quality of $Ra \leq 3.2 \mu m$
- Recommended bore tolerance H8 with a surface quality of $Ra \leq 3.2 \mu m$

Ordering example

- FASTEX IC110 internal clamping set, size 38 x 65

Article no.: FFA:F2E01133797

Size D1 × D2 mm	Dimensions				Screw DIN EN ISO 4762 – 12.9				Surface pressure		Weight m kg	↗ Article no. ²⁾
	LG	L1 mm	L2 mm	L3 mm	SC	T _A ¹⁾ Nm	T _{CL} Nm	F _a kN	P _{SN} N/mm ²	P _{SW} N/mm ²		
19 × 47	48	42	31	26	M6	17	500	52	110	200	0.43	FFA:F2E01133788
20 × 47	48	42	31	26	M6	17	530	52	110	192	0.41	FFA:F2E01133789
22 × 47	48	42	31	26	M6	17	580	52	110	174	0.38	FFA:F2E01133790
24 × 50	48	42	31	26	M6	17	630	52	100	158	0.42	FFA:F2E01133791
25 × 50	48	42	31	26	M6	17	660	52	100	151	0.41	FFA:F2E01133792
28 × 55	48	42	31	26	M6	17	740	52	100	135	0.5	FFA:F2E01133793
30 × 55	48	42	31	26	M6	17	790	52	100	127	0.47	FFA:F2E01133794
32 × 60	48	42	31	26	M6	17	1 150	70	120	161	0.56	FFA:F2E01133795
35 × 60	48	42	31	26	M6	17	1 300	70	120	152	0.53	FFA:F2E01133796
38 × 65	48	42	31	26	M6	17	1 300	70	110	131	0.62	FFA:F2E01133797
40 × 65	48	42	31	26	M6	17	1 400	70	110	127	0.57	FFA:F2E01133798
42 × 75	59	51	35	30	M8	41	2 000	100	120	132	1.01	FFA:F2E01133799
45 × 75	59	51	35	30	M8	41	2 200	100	120	126	0.98	FFA:F2E01133800
48 × 80	59	51	35	30	M8	41	3 200	130	150	161	1.09	FFA:F2E01133801
50 × 80	59	51	35	30	M8	41	3 300	130	150	152	1.07	FFA:F2E01133802
55 × 85	59	51	35	30	M8	41	3 600	130	140	139	1.15	FFA:F2E01133803
60 × 90	59	51	35	30	M8	41	3 900	130	130	126	1.23	FFA:F2E01133804
65 × 95	59	51	35	30	M8	41	4 300	130	120	119	1.32	FFA:F2E01133805
70 × 110	71	61	46	40	M10	83	7 500	210	130	147	2.18	FFA:F2E01133806
75 × 115	71	61	46	40	M10	83	8 000	210	130	138	2.3	FFA:F2E01133827
80 × 120	71	61	46	40	M10	83	8 500	210	120	129	2.44	FFA:F2E01133828
85 × 125	71	61	46	40	M10	83	11 400	270	150	153	2.55	FFA:F2E01133829
90 × 130	71	61	46	40	M10	83	12 000	270	140	144	2.67	FFA:F2E01133830
95 × 135	71	61	46	40	M10	83	12 600	280	135	135	2.8	FFA:F2E01133831
100 × 145	80	68	52	45	M12	145	15 000	300	130	131	3.9	FFA:F2E01133832
110 × 155	80	68	52	45	M12	145	16 500	300	120	119	4.2	FFA:F2E01133833
120 × 165	80	68	52	45	M12	145	22 500	370	140	136	4.5	FFA:F2E01133834
130 × 180	80	68	52	45	M12	145	29 000	450	150	149	5.5	FFA:F2E01133835
140 × 190	90	76	58	50	M14	210	32 000	460	130	128	6.6	FFA:F2E01133836
150 × 200	90	76	58	50	M14	210	41 000	550	150	143	6.9	FFA:F2E01133837
160 × 210	90	76	58	50	M14	210	44 000	550	140	134	7.4	FFA:F2E01133838
170 × 225	90	76	58	50	M14	210	54 500	640	160	148	8.6	FFA:F2E01133839
180 × 235	90	76	58	50	M14	210	57 500	640	150	140	9.1	FFA:F2E01133840
190 × 250	90	76	58	50	M14	210	65 000	689	146	141	10.6	FFA:F2E01133841
200 × 260	90	76	58	50	M14	210	68 000	689	141	133	11.2	FFA:F2E01133842
220 × 285	114	98	72	64	M16	325	82 000	747	109	100	17	FFA:F2E01133843

¹⁾ The specified tightening torques T_A are the maximum values. The tightening torque can be reduced by max. 40% to proportionally reduce the transmissible torque T_{CL}, the transmissible axial force F_a and the surface pressures P_{SN} and P_{SW}.

↗ For online configuration on flender.com, click on the item no.

FASTEX IC120

self-centering with axial hub displacement

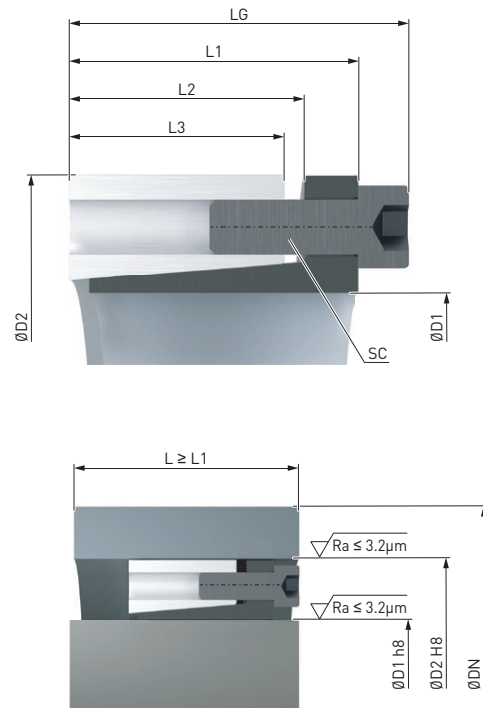

Hub exemplary applications

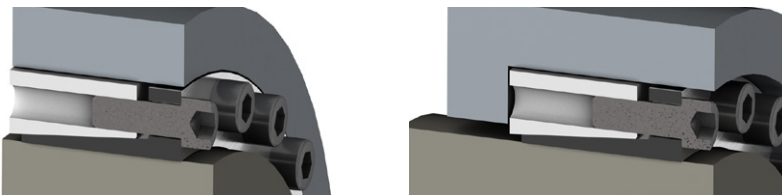

Notes

- Temperature range -20 to 160 °C
- Recommended shaft tolerances h8 with a surface quality of $Ra \leq 3.2 \mu\text{m}$
- Recommended bore tolerance H8 with a surface quality of $Ra \leq 3.2 \mu\text{m}$

Ordering example

- FASTEX IC120 internal clamping set, size 35 x 60

Article no.: FFA:F2E01133777

Size D1 × D2 mm	Dimensions				Screw DIN EN ISO 4762 – 12.9				Surface pressure		Weight m kg	↗ Article no. ²⁾
	L _G mm	L ₁ mm	L ₂ mm	L ₃ mm	SC	T _A ¹⁾ Nm	T _{CL} Nm	F _a kN	P _{SN} N/mm ²	P _{SW} N/mm ²		
18 × 47	34	28	22	17	M6	14	370	41	140	246	0.28	FFA:F2E01133768
19 × 47	34	28	22	17	M6	14	390	41	140	233	0.27	FFA:F2E01133769
20 × 47	34	28	22	17	M6	14	410	41	140	221	0.26	FFA:F2E01133770
22 × 47	34	28	22	17	M6	14	450	41	140	201	0.25	FFA:F2E01133771
24 × 50	34	28	22	17	M6	14	490	41	130	184	0.28	FFA:F2E01133772
25 × 50	34	28	22	17	M6	14	510	41	130	177	0.27	FFA:F2E01133773
28 × 55	34	28	22	17	M6	14	570	41	120	158	0.32	FFA:F2E01133774
30 × 55	34	28	22	17	M6	14	610	41	120	148	0.3	FFA:F2E01133775
32 × 60	34	28	22	17.5	M6	14	880	55	145	184	0.37	FFA:F2E01133776
35 × 60	34	28	22	17.5	M6	14	960	55	145	169	0.34	FFA:F2E01133777
38 × 65	34	28	22	17.5	M6	14	1 000	55	135	155	0.41	FFA:F2E01133778
40 × 65	34	28	22	17.5	M6	14	1 100	55	135	148	0.38	FFA:F2E01133779
42 × 75	41	33	25	20	M8	35	2 200	105	190	220	0.63	FFA:F2E01133780
45 × 75	41	33	25	20	M8	35	2 400	105	190	210	0.63	FFA:F2E01133781
48 × 80	41	33.5	24	20	M8	35	2 500	105	175	184	0.69	FFA:F2E01133782
50 × 80	41	33.5	24	20	M8	35	2 600	105	175	176	0.68	FFA:F2E01133783
55 × 85	41	33.5	24	20	M8	35	2 900	105	165	162	0.73	FFA:F2E01133784
60 × 90	41	33.5	24	20	M8	35	3 100	105	155	147	0.78	FFA:F2E01133785
65 × 95	41	33.5	24	20	M8	35	3 400	105	150	136	0.84	FFA:F2E01133786
70 × 110	50	40	29	24	M10	70	6 000	170	175	176	1.53	FFA:F2E01133847
75 × 115	50	40	29	24	M10	70	6 400	170	170	164	1.63	FFA:F2E01133848
80 × 120	50	40	29	24	M10	70	6 800	170	160	154	1.72	FFA:F2E01133849
85 × 125	50	40	29	24	M10	70	9 000	210	190	179	1.83	FFA:F2E01133850
90 × 130	50	40	29	24	M10	70	9 600	210	185	171	1.9	FFA:F2E01133851
95 × 135	50	40	29	24	M10	70	10 200	210	185	163	2	FFA:F2E01133852
100 × 145	56	44	31	25.5	M12	115	12 000	235	170	160	2.6	FFA:F2E01133853
110 × 155	56	44	31	25.5	M12	115	13 000	260	160	144	2.8	FFA:F2E01133854
120 × 165	56	44	31	26	M12	115	16 000	270	165	148	3.6	FFA:F2E01133855
130 × 180	64	52	39	34	M12	115	23 000	350	155	151	4.4	FFA:F2E01133856
140 × 190	68	54	39	34	M14	185	25 000	360	150	138	4.9	FFA:F2E01133857
150 × 200	68	54	39	34	M14	185	30 000	400	155	143	5.2	FFA:F2E01133858
160 × 210	68	54	39	34	M14	185	38 800	480	170	161	5.6	FFA:F2E01133859
170 × 225	78	64	49	44	M14	185	41 300	480	130	126	6.9	FFA:F2E01133860
180 × 235	78	64	49	44	M14	185	43 700	480	125	119	8.5	FFA:F2E01133861
190 × 250	78	64	49	43.5	M14	185	57 700	600	145	141	9	FFA:F2E01133862
200 × 260	78	64	49	43.5	M14	185	60 700	600	140	134	9.6	FFA:F2E01133863
220 × 285	88	72	57	50	M16	290	78 100	710	132	131	13.42	FFA:F2E01133864
240 × 305	88	72	57	50	M16	290	106 500	848	154	150	14.46	FFA:F2E01133865
260 × 325	88	72	57	50	M16	290	138 500	1017	174	167	16.11	FFA:F2E01133866
280 × 355	102	84	66	60	M18	400	160 300	1094	143	141	23.44	FFA:F2E01133867
300 × 375	102	84	66	60	M18	400	193 200	1230	152	148	25.28	FFA:F2E01133868
320 × 405	121	101	81	74	M20	580	272 700	1627	151	152	36.94	FFA:F2E01133869
340 × 425	121	101	81	74	M20	580	338 000	1899	168	167	39	FFA:F2E01133870
360 × 455	138	116	93	86	M22	780	375 700	1994	142	144	54	FFA:F2E01133871
380 × 475	138	116	93	86	M22	780	462 700	2326	158	160	56.2	FFA:F2E01133872
400 × 495	138	116	93	86	M22	780	487 000	2326	152	152	58.85	FFA:F2E01133873

¹⁾ The specified tightening torques T_A are the maximum values. The tightening torque can be reduced by max. 40% to proportionally reduce the transmissible torque T_{CL}, the transmissible axial force F_a and the surface pressures P_{SN} and P_{SW}.

↗ For online configuration on flender.com, click on the item no.

FASTEX IC130

self-centering with axial hub displacement

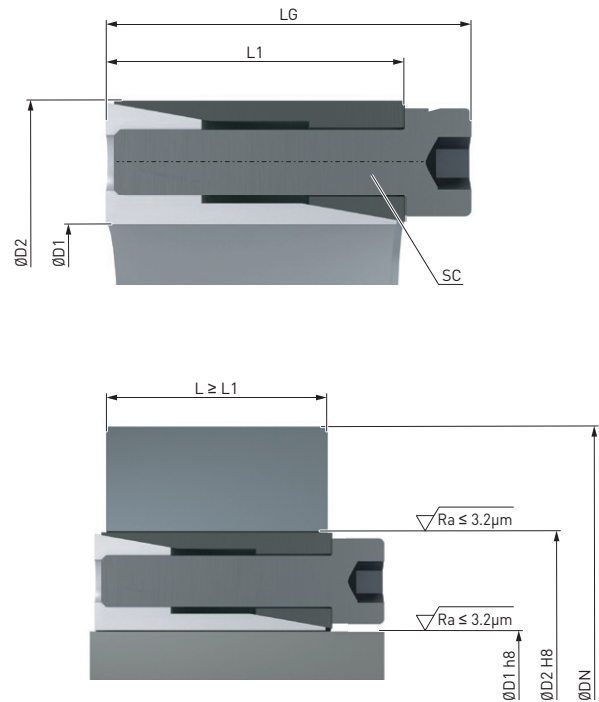
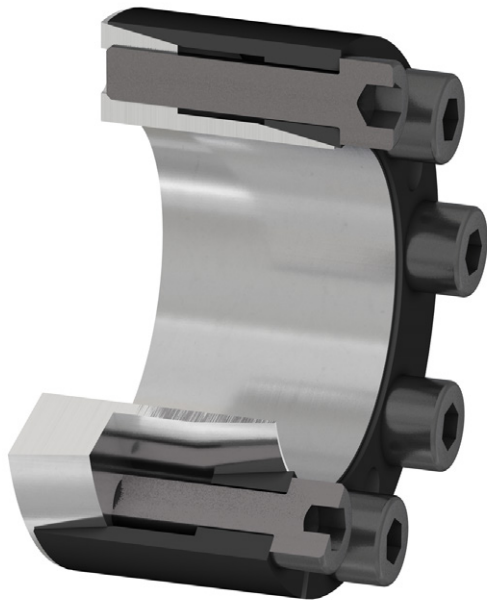

Hub exemplary applications

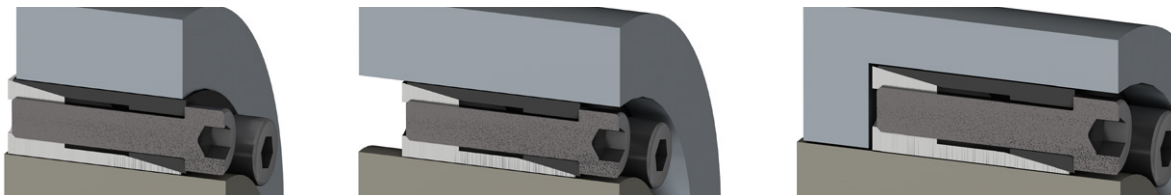

Notes

- Temperature range -20 to 160 °C
- Recommended shaft tolerances h8 with a surface quality of $Ra \leq 3.2 \mu\text{m}$
- Recommended bore tolerance H8 with a surface quality of $Ra \leq 3.2 \mu\text{m}$

Ordering example

- FASTEX IC130 internal clamping set, size 12 x 22

Article no.: FFA:F2E01133816

Size D1 × D2 mm	Dimensions		Screw DIN EN ISO 4762 – 12.9				Surface pressure		Weight m kg	↗ Article no. ²⁾
	LG mm	L1 mm	SC	T_A ¹⁾ Nm	T_{CL} Nm	F_a kN	P_{SN} N/mm ²	P_{SW} N/mm ²		
5 × 16	13.5	11	M2,5	1.2	5	2	55	174	0.01	FFA:F2E01133808
6 × 16	13.5	11	M2,5	1.2	6	2	55	146	0.012	FFA:F2E01133809
6.35 × 16	13.5	11	M2,5	1.2	6	2	55	138	0.012	FFA:F2E01133810
7 × 17	13.5	11	M2,5	1.2	8	2	55	125	0.013	FFA:F2E01133811
8 × 18	13.5	11	M2,5	1.2	10	2.5	50	109	0.015	FFA:F2E01133812
9 × 20	15.5	13	M2,5	1.2	15	3	55	127	0.02	FFA:F2E01133813
10 × 20	15.5	13	M2,5	1.2	15	3	55	114	0.019	FFA:F2E01133814
11 × 22	15.5	13	M2,5	1.2	18	3	50	104	0.024	FFA:F2E01133815
12 × 22	15.5	13	M2,5	1.2	20	3	50	95	0.022	FFA:F2E01133816
14 × 26	20	17	M3	2.1	35	5	55	89	0.039	FFA:F2E01133817
15 × 28	20	17	M3	2.1	40	5	50	84	0.044	FFA:F2E01133818
16 × 32	21	17	M4	4.9	70	8	65	140	0.067	FFA:F2E01133819
17 × 35	25	21	M4	4.9	75	8	60	111	0.09	FFA:F2E01133820
18 × 35	25	21	M4	4.9	80	8	60	104	0.087	FFA:F2E01133821
19 × 35	25	21	M4	4.9	85	8	60	99	0.083	FFA:F2E01133822
20 × 38	26	21	M5	9.7	150	15	75	151	0.1	FFA:F2E01133823
22 × 40	26	21	M5	9.7	160	14	70	138	0.11	FFA:F2E01133824
24 × 47	32	26	M6	16.5	250	20	75	143	0.2	FFA:F2E01133825
25 × 47	32	26	M6	16.5	260	20	75	138	0.19	FFA:F2E01133826
28 × 50	32	26	M6	16.5	440	30	100	189	0.22	FFA:F2E01133887
30 × 55	32	26	M6	16.5	470	30	95	176	0.27	FFA:F2E01133888
32 × 55	32	26	M6	16.5	500	30	95	165	0.25	FFA:F2E01133889
35 × 60	37	31	M6	16.5	730	40	95	161	0.36	FFA:F2E01133890
38 × 65	37	31	M6	16.5	800	40	90	148	0.43	FFA:F2E01133891
40 × 65	37	31	M6	16.5	840	40	90	141	0.4	FFA:F2E01133892
42 × 75	44	36	M8	40	1 600	75	120	213	0.68	FFA:F2E01133893
45 × 75	44	36	M8	40	1 700	75	120	199	0.63	FFA:F2E01133894
48 × 80	44	36	M8	40	1 850	75	115	186	0.73	FFA:F2E01133895
50 × 80	44	36	M8	40	1 900	75	115	178	0.7	FFA:F2E01133896

¹⁾ The specified tightening torques T_A are the maximum values. The tightening torque can be reduced by max. 40% to proportionally reduce the transmissible torque T_{CL} , the transmissible axial force F_a and the surface pressures P_{SN} and P_{SW} .

↗ For online configuration on fletcher.com, click on the item no.

FASTEX IC210

self-centering without axial hub displacement

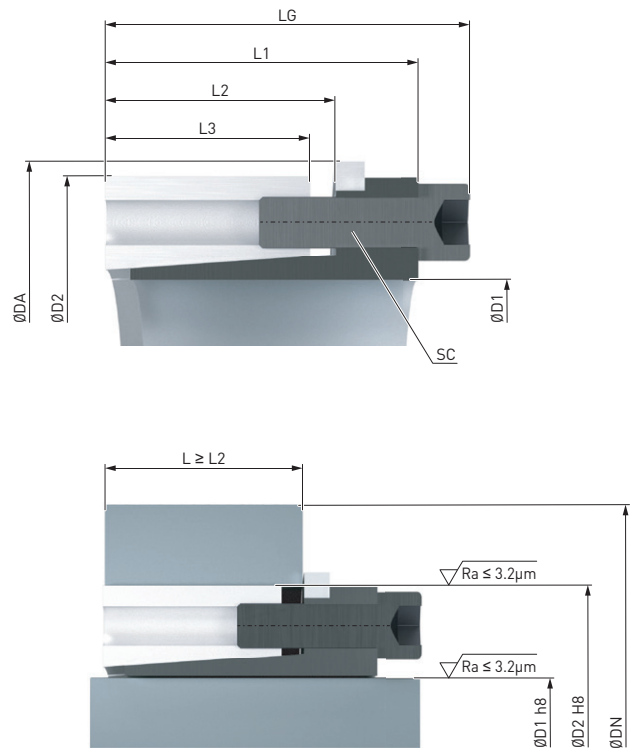

Hub exemplary applications

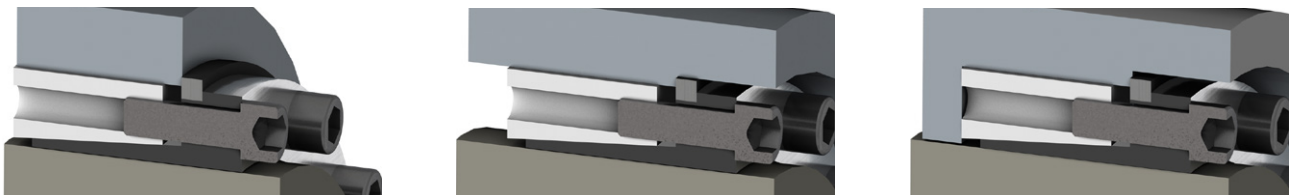

Notes

- Temperature range -20 to 160 °C
- No axial displacement due to fixed backstop point
- Recommended shaft tolerances h8 with a surface quality of $Ra \leq 3.2 \mu\text{m}$
- Recommended bore tolerance H8 with a surface quality of $Ra \leq 3.2 \mu\text{m}$

Ordering example

- FASTEX IC210 internal clamping set, size 35 x 60

Article no.: FFA:F2E01133912

Size D1 × D2 mm	Dimensions					Screw DIN EN ISO 4762 – 12.9				Surface pressure		Weight m kg	↗ Article no. ²⁾
	DA mm	LG mm	L1 mm	L2 mm	L3 mm	SC	T _A ¹⁾ Nm	T _{CL} Nm	F _a kN	P _{SN} N/mm ²	P _{SW} N/mm ²		
19 × 47	53	48	42	31	26	M6	17	300	33	70	124	0.44	FFA:F2E01133844
20 × 47	53	48	42	31	26	M6	17	320	33	70	118	0.42	FFA:F2E01133845
22 × 47	53	48	42	31	26	M6	17	360	33	70	107	0.39	FFA:F2E01133846
24 × 50	56	48	42	31	26	M6	17	390	33	70	98	0.43	FFA:F2E01133907
25 × 50	56	48	42	31	26	M6	17	400	33	70	94	0.42	FFA:F2E01133908
28 × 55	61	48	42	31	26	M6	17	450	33	60	85	0.51	FFA:F2E01133909
30 × 55	61	48	42	31	26	M6	17	490	33	60	79	0.48	FFA:F2E01133910
32 × 60	66	48	42	31	26	M6	17	690	43	70	98	0.57	FFA:F2E01133911
35 × 60	66	48	42	31	26	M6	17	750	43	70	90	0.54	FFA:F2E01133912
38 × 65	71	48	42	31	26	M6	17	820	43	70	83	0.63	FFA:F2E01133913
40 × 65	71	48	42	31	26	M6	17	860	43	70	79	0.58	FFA:F2E01133914
42 × 75	81	59	51	35	30	M8	41	1 300	60	70	85	1.02	FFA:F2E01133915
45 × 75	81	59	51	35	30	M8	41	1 400	60	70	80	0.99	FFA:F2E01133916
48 × 80	86	59	51	35	30	M8	41	1 900	80	90	96	1.1	FFA:F2E01133917
50 × 80	86	59	51	35	30	M8	41	2 000	80	90	93	1.08	FFA:F2E01133918
55 × 85	91	59	51	35	30	M8	41	2 200	80	90	84	1.16	FFA:F2E01133919
60 × 90	96	59	51	35	30	M8	41	2 400	80	80	78	1.24	FFA:F2E01133920
65 × 95	101	59	51	35	30	M8	41	2 600	80	70	71	1.33	FFA:F2E01133921
70 × 110	119	71	61	46	40	M10	83	4 600	130	80	91	2.29	FFA:F2E01133922
75 × 115	124	71	61	46	40	M10	83	5 000	130	80	86	2.41	FFA:F2E01133923
80 × 120	129	71	61	46	40	M10	83	5 200	130	70	79	2.56	FFA:F2E01133924
85 × 125	134	71	61	46	40	M10	83	7 000	170	90	93	2.67	FFA:F2E01133925
90 × 130	139	71	61	46	40	M10	83	7 400	170	80	88	2.8	FFA:F2E01133926
95 × 135	144	71	61	46	40	M10	83	7 800	170	80	83	2.93	FFA:F2E01133927
100 × 145	155	80	68	52	45	M12	145	9 800	190	80	85	4.1	FFA:F2E01133928
110 × 155	165	80	68	52	45	M12	145	10 700	190	70	77	4.4	FFA:F2E01133929
120 × 165	175	80	68	52	45	M12	145	14 600	240	90	88	4.72	FFA:F2E01133930
130 × 180	188	80	68	52	45	M12	145	19 000	300	100	98	5.74	FFA:F2E01133931
140 × 190	199	90	76	58	50	M14	230	23 000	330	90	92	6.92	FFA:F2E01133932
150 × 200	209	90	76	58	50	M14	230	30 000	400	100	104	7.24	FFA:F2E01133933
160 × 210	219	90	76	58	50	M14	230	32 000	400	100	98	7.76	FFA:F2E01133934
170 × 225	234	90	76	58	50	M14	230	39 000	460	110	106	8.98	FFA:F2E01133935
180 × 235	244	90	76	58	50	M14	230	41 000	460	100	99	9.5	FFA:F2E01133936
190 × 250	259	90	76	58	50	M14	230	46 400	488	104	101	11.1	FFA:F2E01133937
200 × 260	269	90	76	58	50	M14	230	48 800	488	100	96	11.7	FFA:F2E01133938
220 × 285	294	114	98	72	64	M16	360	59 900	544	79	73	17.5	FFA:F2E01133939

¹⁾ The specified tightening torques T_A are the maximum values. The tightening torque can be reduced by max. 40% to proportionally reduce the transmissible torque T_{CL}, the transmissible axial force F_a and the surface pressures P_{SN} and P_{SW}.

↗ For online configuration on flender.com, click on the item no.

FASTEX IC220

self-centering without axial hub displacement

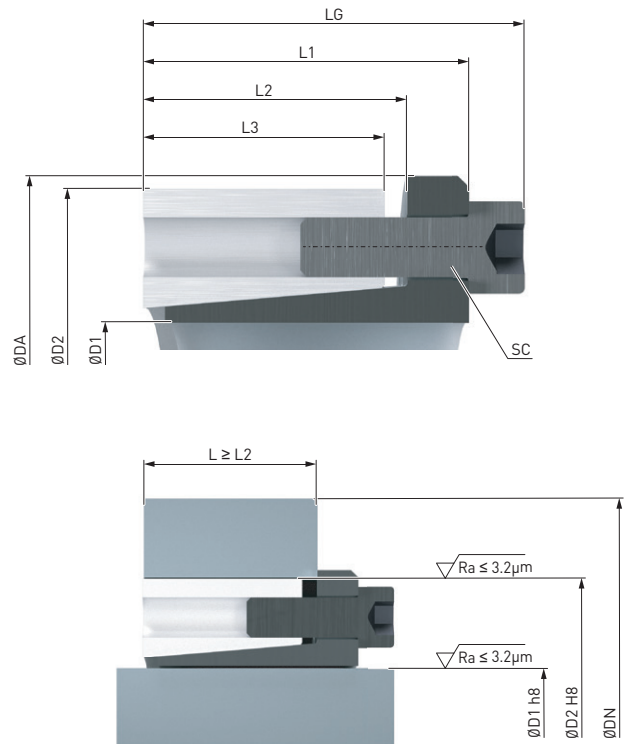

Hub exemplary applications

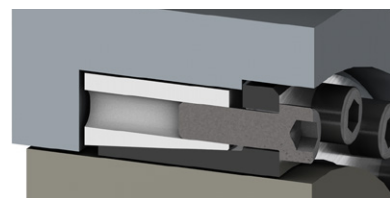
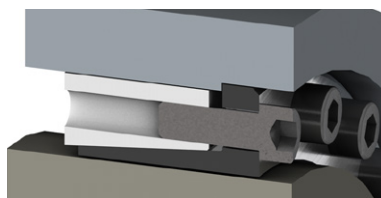
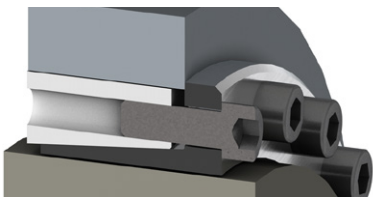

Notes

- Temperature range -20 to 160 °C
- No axial displacement due to fixed backstop point
- Recommended shaft tolerances h8 with a surface quality of $Ra \leq 3.2 \mu m$
- Recommended bore tolerance H8 with a surface quality of $Ra \leq 3.2 \mu m$

Ordering example

- FASTEX IC220 internal clamping set, size 40 x 65

Article no.: FFA:F2E01133885

Size D1 × D2 mm	Dimensions					Screw DIN EN ISO 4762 – 12.9				Surface pressure		Weight m kg	↗ Article no. ²⁾
	DA mm	LG mm	L1 mm	L2 mm	L3 mm	SC	T _A ¹⁾ Nm	T _{CL} Nm	F _a kN	P _{SN} N/mm ²	P _{SW} N/mm ²		
18 × 47	53	34	28	22	17	M6	17	290	32	100	190	0.28	FFA:F2E01133874
19 × 47	53	34	28	22	17	M6	17	300	32	100	180	0.28	FFA:F2E01133875
20 × 47	53	34	28	22	17	M6	17	320	32	100	171	0.28	FFA:F2E01133876
22 × 47	53	34	28	22	17	M6	17	350	32	100	155	0.27	FFA:F2E01133877
24 × 50	56	34	28	22	17	M6	17	390	32	100	142	0.31	FFA:F2E01133878
25 × 50	56	34	28	22	17	M6	17	400	32	100	137	0.30	FFA:F2E01133879
28 × 55	61.4	34	28	22	17	M6	17	450	32	90	122	0.36	FFA:F2E01133880
30 × 55	61.4	34	28	22	17	M6	17	490	32	90	114	0.34	FFA:F2E01133881
32 × 60	67	34	28	22	17.5	M6	17	700	43	110	145	0.34	FFA:F2E01133882
35 × 60	67	34	28	22	17.5	M6	17	760	43	110	133	0.39	FFA:F2E01133883
38 × 65	72	34	28	22	17.5	M6	17	820	43	100	122	0.45	FFA:F2E01133884
40 × 65	72	34	28	22	17.5	M6	17	870	43	100	116	0.44	FFA:F2E01133885
42 × 75	84	41	33	25	20	M8	41	1 700	80	140	171	0.68	FFA:F2E01133886
45 × 75	84	41	33	25	20	M8	41	1 800	80	140	160	0.70	FFA:F2E01133947
48 × 80	89	41	33.5	24	20	M8	41	1 900	80	130	143	0.80	FFA:F2E01133948
50 × 80	89	41	33.5	24	20	M8	41	2 000	80	130	137	0.75	FFA:F2E01133949
55 × 85	94	41	33.5	24	20	M8	41	2 200	80	120	124	0.85	FFA:F2E01133950
60 × 90	99	41	33.5	24	20	M8	41	2 400	80	120	114	0.90	FFA:F2E01133951
65 × 95	104	41	33.5	24	20	M8	41	2 600	80	110	105	0.93	FFA:F2E01133952
70 × 110	119	50	40	29	24	M10	83	4 600	130	130	135	1.60	FFA:F2E01133953
75 × 115	124	50	40	29	24	M10	83	5 000	130	130	129	1.70	FFA:F2E01133954
80 × 120	129	50	40	29	24	M10	83	5 300	130	120	119	1.85	FFA:F2E01133955
85 × 125	134	50	40	29	24	M10	83	7 000	160	150	139	1.96	FFA:F2E01133956
90 × 130	139	50	40	29	24	M10	83	7 400	160	140	131	2.00	FFA:F2E01133957
95 × 135	144	50	40	29	24	M10	83	7 800	160	130	124	2.30	FFA:F2E01133958
100 × 145	154	56	44	31	25.5	M12	145	9 700	200	140	129	2.80	FFA:F2E01133959
110 × 155	164	56	44	31	25.5	M12	145	10 700	200	130	118	3.10	FFA:F2E01133960
120 × 165	174	56	44	31	26	M12	145	13 100	220	150	121	3.20	FFA:F2E01133961
130 × 180	189	64	52	39	34	M12	145	19 000	290	130	124	4.60	FFA:F2E01133962
140 × 190	199	68	54	39	34	M14	230	20 500	300	140	111	4.98	FFA:F2E01133963
150 × 200	209	68	54	39	34	M14	230	24 500	330	130	115	5.20	FFA:F2E01133964
160 × 210	219	68	54	39	34	M14	230	31 300	390	150	130	5.60	FFA:F2E01133965
170 × 225	234	78	64	49	44	M14	230	33 200	390	110	102	6.50	FFA:F2E01133966
180 × 235	244	78	64	49	44	M14	230	35 000	390	100	96	8.50	FFA:F2E01133967
190 × 250	259	78	64	49	43.5	M14	230	46 500	500	120	114	9.00	FFA:F2E01133968
200 × 260	269	78	64	49	43.5	M14	230	49 000	500	110	108	9.60	FFA:F2E01133969
220 × 285	294	88	72	57	50	M16	360	57 100	519	97	95	14.02	FFA:F2E01133970
240 × 305	314	88	72	57	50	M16	360	77 800	649	113	109	15.12	FFA:F2E01133971
260 × 325	334	88	72	57	50	M16	360	101 200	778	127	120	16.18	FFA:F2E01133972
280 × 355	364	102	84	66	60	M18	480	113 300	808	101	99	25.57	FFA:F2E01133973
300 × 375	384	102	84	66	60	M18	480	136 500	910	107	104	25.50	FFA:F2E01133974
320 × 405	414	121	101	81	74	M20	690	191 000	1193	106	105	37.94	FFA:F2E01133975
340 × 425	434	121	101	81	74	M20	690	237 000	1393	118	115	38.28	FFA:F2E01133976
360 × 455	464	138	116	93	86	M22	930	264 000	1465	99	100	53.30	FFA:F2E01133977
380 × 475	484	138	116	93	86	M22	930	325 000	1709	111	111	57.55	FFA:F2E01133978
400 × 495	504	138	116	93	86	M22	930	342 000	1709	107	105	60.25	FFA:F2E01133979

¹⁾ The specified tightening torques T_A are the maximum values. The tightening torque can be reduced by max. 40% to proportionally reduce the transmissible torque T_{CL}, the transmissible axial force F_a and the surface pressures P_{SN} and P_{SW}.

↗ For online configuration on flender.com, click on the item no.

FASTEX IC230

self-centering without axial hub displacement

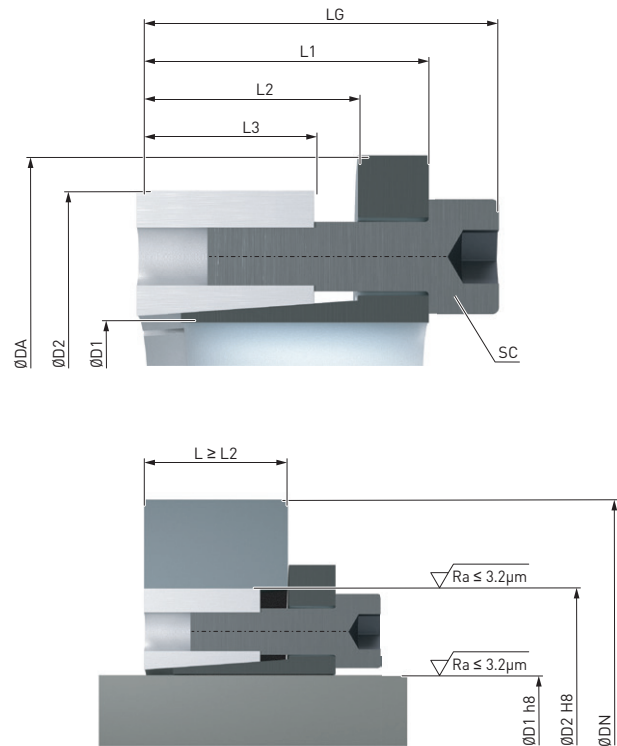
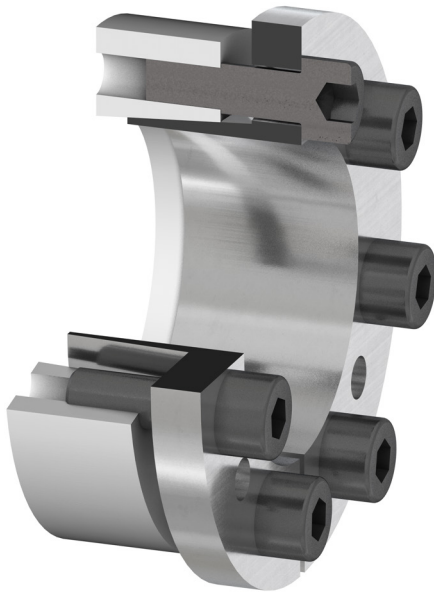

Hub exemplary applications

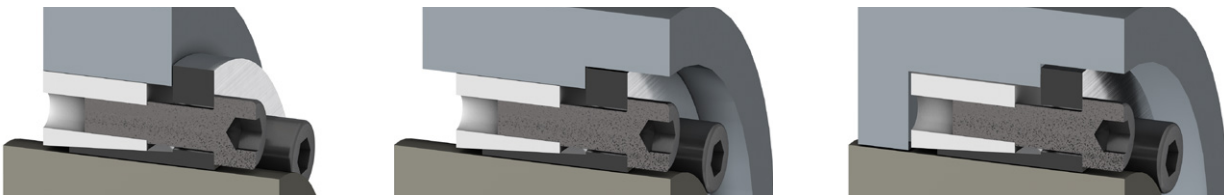

Notes

- Temperature range -20 to 160 °C
- No axial displacement due to fixed backstop point
- Recommended shaft tolerances h8 with a surface quality of $Ra \leq 3.2 \mu\text{m}$
- Recommended bore tolerance H8 with a surface quality of $Ra \leq 3.2 \mu\text{m}$

Ordering example

- FASTEX IC230 internal clamping set, size 25 x 55

Article no.: FFA:F2E01145653

Size D1 × D2 mm	Dimensions					Screw DIN EN ISO 4762 – 12.9				Surface pressure		Weight m kg	↗ Article no. ²⁾
	DA mm	LG mm	L1 mm	L2 mm	L3 mm	SC	T _A ¹⁾ Nm	T _{CL} Nm	F _a kN	P _{SN} N/mm ²	P _{SW} N/mm ²		
14 × 55	62	38	30	22	17	M8	41	287	41	103	458	0.5	FFA:F2E01145606
16 × 55	62	38	30	22	17	M8	41	329	41	103	401	0.49	FFA:F2E01145647
18 × 55	62	38	30	22	17	M8	41	370	41	103	356	0.48	FFA:F2E01145648
19 × 55	62	38	30	22	17	M8	41	390	41	103	337	0.47	FFA:F2E01145649
20 × 55	62	38	30	22	17	M8	41	410	41	103	320	0.46	FFA:F2E01145650
22 × 55	62	38	30	22	17	M8	41	451	41	103	291	0.45	FFA:F2E01145651
24 × 55	62	38	30	22	17	M8	41	492	41	103	267	0.43	FFA:F2E01145652
25 × 55	62	38	30	22	17	M8	41	513	41	103	256	0.42	FFA:F2E01145653
28 × 55	62	38	30	22	17	M8	41	575	41	103	228	0.39	FFA:F2E01145654
30 × 55	62	38	30	22	17	M8	41	616	41	103	214	0.35	FFA:F2E01145655
24 × 65	72	38	30	22	17	M8	41	616	51	111	333	0.66	FFA:F2E01145656
25 × 65	72	38	30	22	17	M8	41	641	51	111	320	0.65	FFA:F2E01145657
28 × 65	72	38	30	22	17	M8	41	718	51	111	286	0.62	FFA:F2E01145658
30 × 65	72	38	30	22	17	M8	41	770	51	111	267	0.6	FFA:F2E01145659
32 × 65	72	38	30	22	17	M8	41	821	51	111	250	0.58	FFA:F2E01145660
35 × 65	72	38	30	22	17	M8	41	898	51	111	228	0.54	FFA:F2E01145661
38 × 65	72	38	30	22	17	M8	41	975	51	111	211	0.5	FFA:F2E01145662
40 × 65	72	38	30	22	17	M8	41	1026	51	111	200	0.47	FFA:F2E01145663
30 × 80	88	41	33	25	20	M8	41	1077	72	108	318	1.08	FFA:F2E01145664
32 × 80	88	41	33	25	20	M8	41	1150	72	108	298	1.05	FFA:F2E01145665
35 × 80	88	41	33	25	20	M8	41	1257	72	108	272	1.01	FFA:F2E01145666
38 × 80	88	41	33	25	20	M8	41	1364	72	108	251	0.97	FFA:F2E01145667
40 × 80	88	41	33	25	20	M8	41	1436	72	108	238	0.94	FFA:F2E01145668
42 × 80	88	41	33	25	20	M8	41	1509	72	108	226	0.91	FFA:F2E01145669
45 × 80	88	41	33	25	20	M8	41	1616	72	108	212	0.85	FFA:F2E01145670
48 × 80	88	41	33	25	20	M8	41	1723	72	108	199	0.79	FFA:F2E01145671
50 × 80	88	41	33	25	20	M8	41	1796	72	108	190	0.75	FFA:F2E01145672

¹⁾ The specified tightening torques T_A are the maximum values. The tightening torque can be reduced by max. 40% to proportionally reduce the transmissible torque T_{CL}, the transmissible axial force F_a and the surface pressures P_{SN} and P_{SW}.

↗ For online configuration on flander.com, click on the item no.

FASTEX IC240

self-centering without axial hub displacement

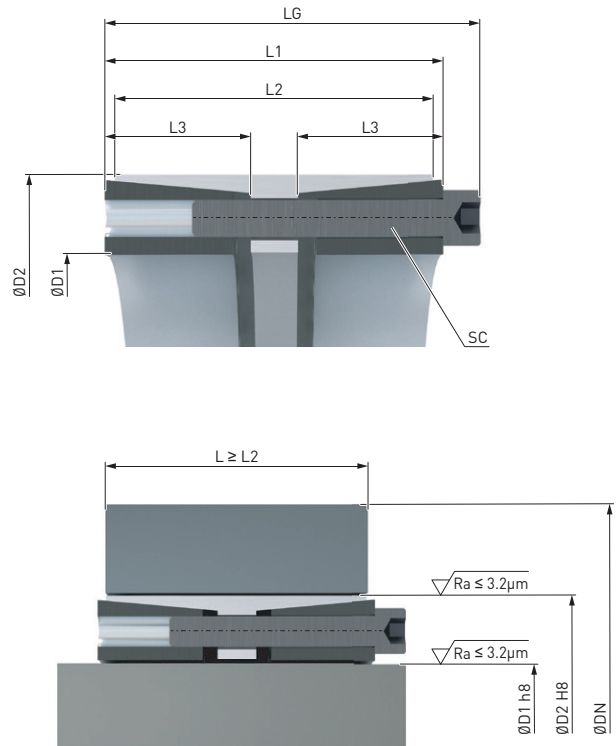
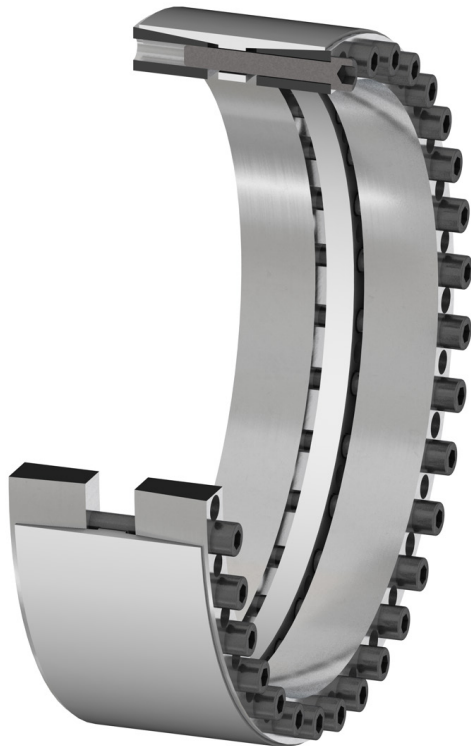

Hub exemplary applications

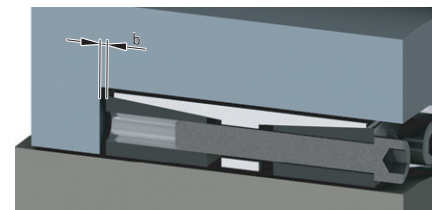
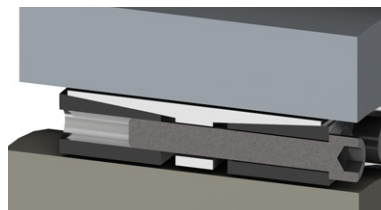
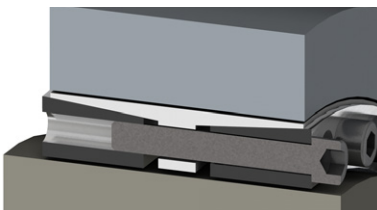

Formula for calculating clearance for disassembly:

$$b = \frac{L1 - L2}{2}$$

Notes

- Temperature range -20 to 160 °C
- Extremely high centering precision due to twin slit
- For highly robust applications
- Recommended shaft tolerances h8 with a surface quality of $Ra \leq 3.2 \mu m$
- Recommended bore tolerance H8 with a surface quality of $Ra \leq 3.2 \mu m$

Ordering example

- FASTEX IC240 internal clamping set, size 50 x 80

Article no.: FFA:F2E01145642

Size D1 × D2 mm	Dimensions				Screw DIN EN ISO 4762 – 12.9				Surface pressure		Weight m kg	↗ Article no. ²⁾
	L _G mm	L ₁ mm	L ₂ mm	L ₃ mm	SC	T _A ¹⁾ Nm	T _{CL} Nm	F _a kN	P _{SN} N/mm ²	P _{SW} N/mm ²		
24 × 50	51	45	41	16	M6	17	700	60	92	226	0.54	FFA:F2E01145630
25 × 50	51	45	41	16	M6	17	730	60	92	217	0.53	FFA:F2E01145631
28 × 55	51	45	41	16	M6	17	1 100	80	112	258	0.50	FFA:F2E01145632
30 × 55	51	45	41	16	M6	17	1 180	80	112	241	0.47	FFA:F2E01145633
32 × 60	51	45	41	16	M6	17	1 270	80	100	226	0.77	FFA:F2E01145634
35 × 60	51	45	41	16	M6	17	1 390	80	100	207	0.71	FFA:F2E01145635
38 × 65	51	45	41	16	M6	17	1 880	100	115	238	1.10	FFA:F2E01145636
40 × 65	51	45	41	16	M6	17	1 980	100	115	226	1.06	FFA:F2E01145637
40 × 75	51	45	41	16	M8	41	2 880	145	145	328	1.10	FFA:F2E01145638
42 × 75	51	45	41	16	M8	41	3 000	145	145	312	1.16	FFA:F2E01145639
45 × 75	51	45	41	16	M8	41	3 250	145	145	292	1.08	FFA:F2E01145640
48 × 80	70	62	58	23	M8	41	3 450	145	95	190	1.45	FFA:F2E01145641
50 × 80	70	62	58	23	M8	41	3 600	145	95	183	1.38	FFA:F2E01145642
55 × 85	70	62	58	23	M8	41	3 950	145	90	166	1.49	FFA:F2E01145643
60 × 90	70	62	58	23	M8	41	5 400	180	107	190	1.60	FFA:F2E01145644
65 × 95	70	62	58	23	M8	41	5 850	180	100	176	1.70	FFA:F2E01145645
70 × 110	86	76	70	28	M10	83	10 200	290	115	217	3.10	FFA:F2E01145646
75 × 115	86	76	70	28	M10	83	10 950	290	110	203	3.29	FFA:F2E01145687
80 × 120	86	76	70	28	M10	83	14 000	350	128	228	3.46	FFA:F2E01145688
85 × 125	86	76	70	28	M10	83	15 000	350	123	215	3.64	FFA:F2E01145689
90 × 130	86	76	70	28	M10	83	15 800	350	118	203	3.80	FFA:F2E01145690
95 × 135	86	76	70	28	M10	83	16 800	350	115	192	4.00	FFA:F2E01145691
100 × 145	110	98	92	35	M12	145	26 000	520	120	216	6.10	FFA:F2E01145692
110 × 155	110	98	92	35	M12	145	28 600	520	110	196	6.60	FFA:F2E01145693
120 × 165	110	98	92	35	M12	145	36 300	605	122	210	7.10	FFA:F2E01145694
130 × 180	128	114	108	41	M14	230	46 000	710	112	194	10.00	FFA:F2E01145695
140 × 190	128	114	108	41	M14	230	57 800	825	123	210	10.60	FFA:F2E01145696
150 × 200	128	114	108	41	M14	230	70 800	945	135	224	11.20	FFA:F2E01145697
160 × 210	128	114	108	41	M14	230	75 500	945	128	210	11.90	FFA:F2E01145698
170 × 225	162	146	136	52	M16	355	95 900	1130	113	186	17.60	FFA:F2E01145699
180 × 235	162	146	136	52	M16	355	108 800	1210	115	188	18.50	FFA:F2E01145700
190 × 250	162	146	136	52	M16	355	122 500	1290	115	190	21.40	FFA:F2E01145701
200 × 260	162	146	136	52	M16	355	128 900	1290	110	181	22.40	FFA:F2E01145702
220 × 285	162	146	136	52	M16	355	171 800	1565	115	185	26.60	FFA:F2E01145703
240 × 305	162	146	136	52	M16	355	208 000	1735	120	188	28.70	FFA:F2E01145704
260 × 325	166	150	134	55	M16	355	237 000	1825	117	175	31.23	FFA:F2E01145705
280 × 355	197	177	165	66	M20	690	340 000	2430	120	180	46.77	FFA:F2E01145706
300 × 375	197	177	165	66	M20	690	405 000	2700	125	187	69.72	FFA:F2E01145707
320 × 405	197	177	165	66	M20	690	453 000	2835	122	184	60.52	FFA:F2E01145708
340 × 425	197	177	165	66	M20	690	504 900	2970	122	181	63.86	FFA:F2E01145709
360 × 455	224	203	190	76	M22	930	626 000	3480	115	174	86.78	FFA:F2E01145710
380 × 475	224	203	190	76	M22	930	692 000	3645	115	173	91.04	FFA:F2E01145711
400 × 495	224	203	190	76	M22	930	795 000	3980	120	179	95.30	FFA:F2E01145712
420 × 515	224	203	190	76	M22	930	835 000	3980	115	171	100.00	FFA:F2E01145713
440 × 535	224	203	190	76	M22	930	875 000	3980	110	161	105.00	FFA:F2E01145714
460 × 555	224	203	190	76	M22	930	914 000	3980	107	154	109.00	FFA:F2E01145715
480 × 575	224	203	190	76	M22	930	1 113 000	4640	120	174	114.00	FFA:F2E01145716
500 × 595	224	203	190	76	M22	930	1 160 000	4640	115	165	119.00	FFA:F2E01145717
520 × 615	224	203	190	76	M22	930	1 292 000	4970	120	170	122.50	FFA:F2E01145718
540 × 635	224	203	190	76	M22	930	1 342 000	4970	115	164	128.00	FFA:F2E01145719
560 × 655	224	203	190	76	M22	930	1 484 000	5300	120	169	131.00	FFA:F2E01145720
580 × 675	224	203	190	76	M22	930	1 537 000	5300	117	163	136.00	FFA:F2E01145721
600 × 695	224	203	190	76	M22	930	1 640 000	5470	117	162	139.00	FFA:F2E01145722

¹⁾ The specified tightening torques T_A are the maximum values. The tightening torque can be reduced by max. 40% to proportionally reduce the transmissible torque T_{CL}, the transmissible axial force F_a and the surface pressures P_{SN} and P_{SW}.

↗ For online configuration on flender.com, click on the item no.

FASTEX IC250

self-centering without axial hub displacement

1

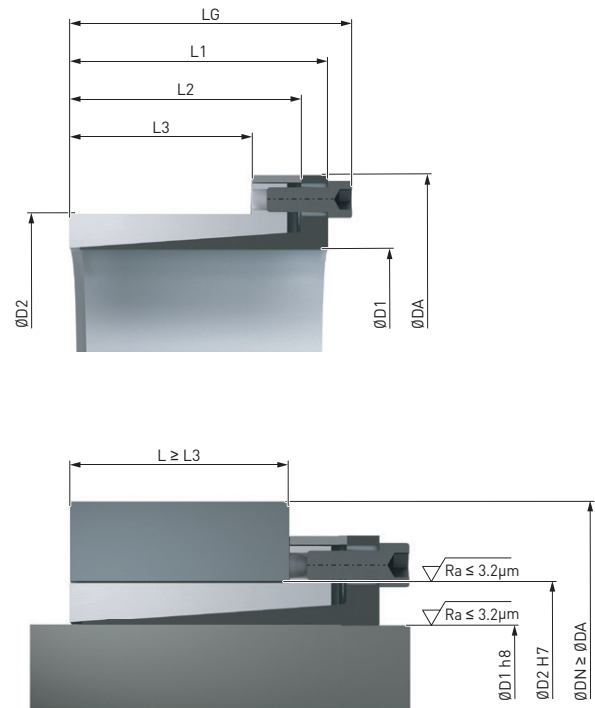
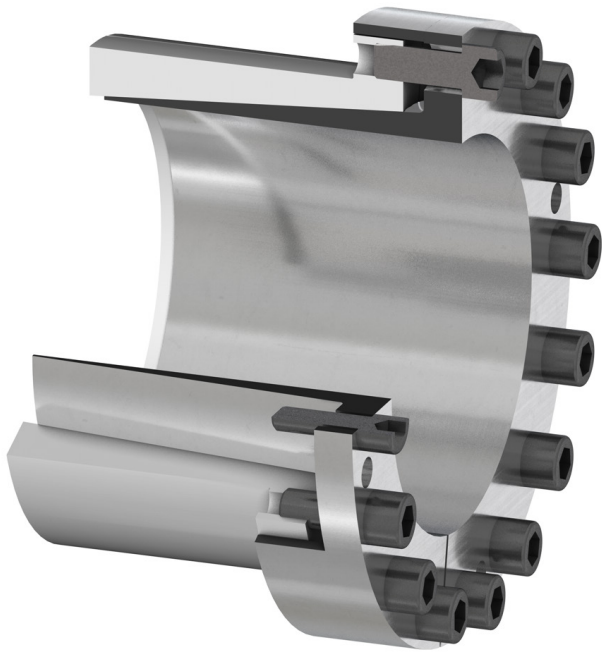

Hub exemplary applications

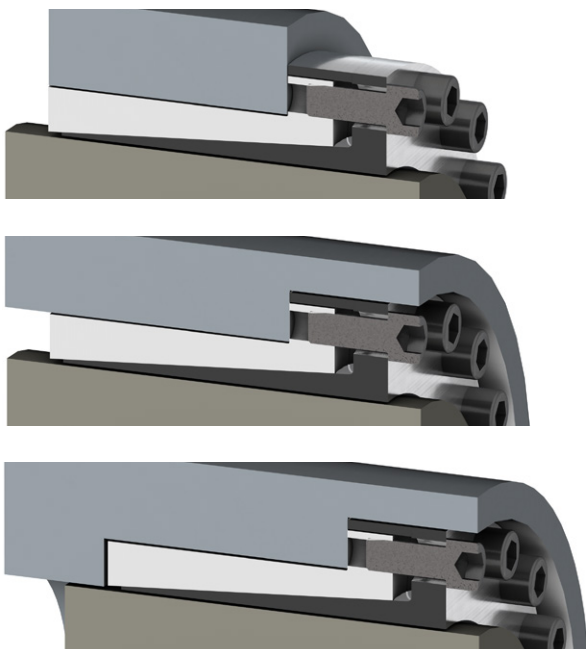

Notes

- Temperature range -20 to 160 °C
- No axial displacement due to fixed backstop point
- Particularly suitable for small hub outer diameters
- Recommended shaft tolerances h8, j7, k6 or m6 with a surface quality of $Ra \leq 3.2 \mu m$
- Recommended bore tolerance H7 with a surface quality of $Ra \leq 3.2 \mu m$

Ordering example

- FASTEX IC250 internal clamping set, size 16 x 24

Article no.: FFA:F2E01145625

Size D1 × D2 mm	Dimensions					Screw DIN EN ISO 4762 – 12.9				Surface pressure		Weight m kg	↗ Article no. ²⁾
	DA mm	LG mm	L1 mm	L2 mm	L3 mm	SC	T _A ¹⁾ Nm	T _{CL} Nm	F _a kN	P _{SN} N/mm ²	P _{SW} N/mm ²		
6 × 14	25	24.5	21.5	18.5	10	M3	2.6	11	3.8	68	87	0.05	FFA:F2E01145615
7 × 15	25	29	25	22	11.5	M4	5.6	23	6.5	98	115	0.05	FFA:F2E01145616
8 × 15	27	29	25	21.5	11.5	M4	5.6	26	6.5	98	103	0.05	FFA:F2E01145617
9 × 16	28	30	26	22.5	14	M4	5.6	37	8	98	122	0.06	FFA:F2E01145618
10 × 16	29	30	26	22.5	14	M4	5.6	42	8	98	110	0.16	FFA:F2E01145619
11 × 18	32	30	26	22.5	13.5	M4	5.6	50	9	100	96	0.18	FFA:F2E01145620
12 × 18	32	30	26	22.5	13.5	M4	5.6	55	9	100	91	0.18	FFA:F2E01145621
13 × 23	38	30	26	22.5	14	M4	5.6	60	9	80	84	0.20	FFA:F2E01145622
14 × 23	38	30	26	22.5	14	M4	5.6	100	14	120	117	0.20	FFA:F2E01145623
15 × 24	44	42	36	28.5	16	M6	15	145	19	130	104	0.21	FFA:F2E01145624
16 × 24	44	42	36	28.5	16	M6	15	155	19	130	97	0.28	FFA:F2E01145625
17 × 25	45	42	36	28.5	16	M6	15	162	19	125	91	0.22	FFA:F2E01145626
17 × 26	47	44	38	31	18	M6	17	180	23	122	104	0.23	FFA:F2E01145727
18 × 26	47	44	38	31	18	M6	17	200	23	120	101	0.23	FFA:F2E01145728
19 × 27	48	44	38	31	18	M6	17	210	23	120	96	0.25	FFA:F2E01145729
20 × 28	49	44	38	31	18	M6	17	220	23	120	91	0.24	FFA:F2E01145730
22 × 32	54	51	45	38	25	M6	17	250	23	70	69	0.32	FFA:F2E01145731
24 × 34	56	51	45	38	25	M6	17	270	23	70	63	0.34	FFA:F2E00872450
25 × 34	56	51	45	38	25	M6	17	280	23	70	60	0.33	FFA:F2E00860932
28 × 39	61	51	45	38	25	M6	17	480	34	90	81	0.41	FFA:F2E00872451
30 × 41	62	51	45	38	25	M6	17	510	34	84	75	0.41	FFA:F2E00860933
32 × 43	65	51	45	38	25	M6	17	730	46	115	95	0.48	FFA:F2E00872452
35 × 47	69	56	50	43	30	M6	17	800	46	81	77	0.53	FFA:F2E00872453
38 × 50	72	56	50	43	30	M6	17	860	46	76	71	0.58	FFA:F2E00860934
40 × 53	75	56	50	43	30	M6	17	900	46	72	67	0.62	FFA:F2E00860935
42 × 55	78	65	57	49	32	M8	41	1 800	84	125	104	0.88	FFA:F2E00872454
45 × 59	85	73	65	57	40	M8	41	1 900	84	89	84	1.03	FFA:F2E00872455
48 × 62	87	78	70	62	45	M8	41	2 000	84	75	72	0.98	FFA:F2E00860936
50 × 65	92	78	70	62	45	M8	41	2 600	105	90	87	1.27	FFA:F2E00872456
55 × 71	98	83	75	67	50	M8	41	2 900	105	70	73	1.49	FFA:F2E00860937
60 × 77	104	83	75	67	50	M8	41	3 100	105	70	67	1.66	FFA:F2E00872457
65 × 84	111	83	75	67	50	M8	41	3 400	105	60	62	1.92	FFA:F2E00860938
70 × 90	119	101	91	80	60	M10	83	5 800	170	80	75	2.93	FFA:F2E00860939
75 × 95	126	101	91	80	60	M10	83	6 200	170	70	71	2.29	FFA:F2E00860940
80 × 100	131	106	96	85	65	M10	83	8 000	200	80	75	3.34	FFA:F2E00872458
85 × 106	137	106	96	85	65	M10	83	8 500	200	70	70	3.62	FFA:F2E00860941
90 × 112	143	106	96	85	65	M10	83	11 200	250	90	82	3.95	FFA:F2E01145733
95 × 120	153	106	96	85	65	M10	83	11 800	250	80	78	4.46	FFA:F2E01145734
100 × 125	162	114	102	89	65	M12	145	14 600	300	95	82	5.50	FFA:F2E01145735
110 × 140	180	140	128	114	90	M12	145	16 000	300	61	58	8.00	FFA:F2E01145736
120 × 155	198	140	128	114	90	M12	145	17 400	300	55	53	10.50	FFA:F2E01145737
130 × 165	208	140	128	114	90	M12	145	25 000	389	69	65	11.90	FFA:F2E01145738

¹⁾ The specified tightening torques T_A are the maximum values. The tightening torque can be reduced by max. 40% to proportionally reduce the transmissible torque T_{CL}, the transmissible axial force F_a and the surface pressures P_{SN} and P_{SW}.

↗ For online configuration on flender.com, click on the item no.

FASTEX IN110

non-self-centering with axial hub displacement,
for shaft diameters from 6 to 80 mm

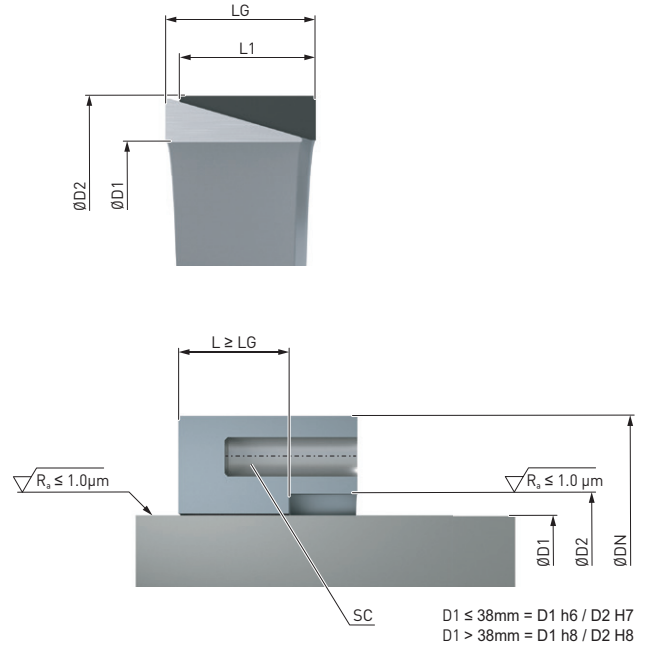

Hub exemplary applications

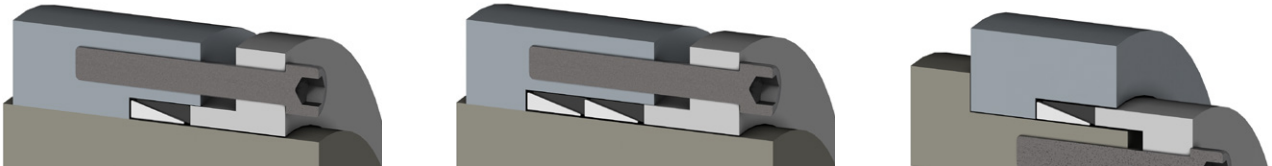

Pressure flange exemplary applications

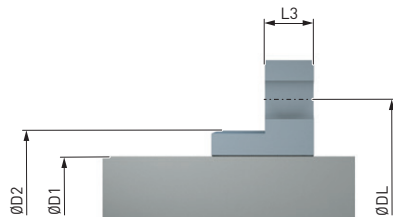
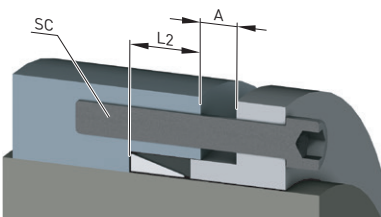

Recommended dimensions of the pressure flange in mm:

$$L2 \geq 1.5 \cdot LG$$

$$DL = D2 + 12 + SC$$

$$L3 = 1.3 \cdot SC \text{ (for screws 8.8)}$$

$$L3 = 1.8 \cdot SC \text{ (for screws 10.9/12.9)}$$

Notes

- Temperature range -20 to 160 °C
- Suitable for individual clamping connections
- Up to 4 clamping elements can be installed one after the other
- Recommended shaft tolerances h6 (D1 ≤ 38 mm), h8 (D1 > 38 mm) with a surface quality of Ra ≤ 1.0 µm
- Recommended bore tolerance H7 (D1 ≤ 38 mm), H8 (D1 > 38 mm) with a surface quality of Ra ≤ 1.0 µm

Ordering example

- FASTEX IN110 internal clamping set, size 15 x 19, slotted

Article no.: FFA:F2E01145761

Size D1 × D2 mm	Dimensions		Clearance				Clamping connection				Surface pressure		Weight m kg	↗ Article no. ¹⁾	
	LG mm	L1 mm	A at number clamping elements				F _{Pre} Standard kN	slotted kN	T _{CL} Nm	F _a kN	P _{SN} N/mm ²	P _{SW} N/mm ²		Standard	slotted
			1 mm	2 mm	3 mm	4 mm									
6 × 9	4.5	3.7	3	3	3	4	11	3	2	0.8	75	113	0.0015	FFA:F2E01145723	FFA:F2E01145724
7 × 10	4.5	3.7	3	3	3	4	14	5	4	1	84	117	0.0014	FFA:F2E01145725	FFA:F2E01145726
8 × 11	4.5	3.7	3	3	3	4	14	6	5	1	90	112	0.0015	FFA:F2E01145747	FFA:F2E01145748
9 × 12	4.5	3.7	3	3	3	4	16	8	8	1.6	95	142	0.0017	FFA:F2E01145749	FFA:F2E01145750
10 × 13	4.5	3.7	3	3	3	4	16	9	10	2	100	143	0.0018	FFA:F2E01145751	FFA:F2E01145752
11 × 14	4.5	3.7	3	3	3	4	15	-	10	2	95	119	0.0020	FFA:F2E01145753	-
12 × 15	4.5	3.7	3	3	3	4	15	9	11	2	90	110	0.0022	FFA:F2E01145754	FFA:F2E01145755
13 × 16	4.5	3.7	3	3	3	4	16	10	13	2.1	105	110	0.0023	FFA:F2E01145756	FFA:F2E01145757
14 × 18	6.3	5.3	3	4	4	5	26	15	22	3	90	112	0.0049	FFA:F2E01145758	FFA:F2E01145759
15 × 19	6.3	5.3	3	4	4	5	26	16	25	3	90	111	0.0053	FFA:F2E01145760	FFA:F2E01145761
16 × 20	6.3	5.3	3	4	4	5	25	-	26	3	90	102	0.0055	FFA:F2E01145762	-
17 × 21	6.3	5.3	3	4	4	5	26	16	30	3	90	104	0.0058	FFA:F2E01145763	FFA:F2E01145764
18 × 22	6.3	5.3	3	4	4	5	26	17	33	3	90	102	0.0061	FFA:F2E01145765	FFA:F2E01145766
19 × 24	6.3	5.3	3	4	4	5	32	20	40	4	90	111	0.0078	FFA:F2E01145767	FFA:F2E01145768
20 × 25	6.3	5.3	3	4	4	5	32	-	44	4	90	110	0.0082	FFA:F2E01145769	-
22 × 26	6.3	5.3	3	4	4	5	30	21	50	4	90	103	0.0072	FFA:F2E01145770	FFA:F2E01145771
24 × 28	6.3	5.3	3	4	4	5	34	26	68	6	100	118	0.0079	FFA:F2E01145772	FFA:F2E01145773
25 × 30	6.3	5.3	3	4	4	5	37	28	75	6	100	120	0.0100	FFA:F2E01145774	FFA:F2E01145775
28 × 32	6.3	5.3	3	4	4	5	37	30	90	6	100	115	0.0090	FFA:F2E01145776	FFA:F2E01145777
30 × 35	6.3	5.3	3	4	4	5	39	-	100	7	100	111	0.012	FFA:F2E01145778	-
32 × 36	6.3	5.3	3	4	4	5	42	35	120	7	100	117	0.01	FFA:F2E01145779	FFA:F2E01145780
35 × 40	7	6	3	4	4	5	55	42	160	9	100	115	0.02	FFA:F2E01145781	FFA:F2E01145782
36 × 42	7	6	4	5	5	6	58	-	170	9.5	100	116	0.02	FFA:F2E01145783	-
38 × 44	7	6	4	5	5	6	60	46	190	10	100	116	0.02	FFA:F2E01145784	FFA:F2E01145785
40 × 45	8	6.6	4	5	5	6	67	53	230	11	100	116	0.02	FFA:F2E01145786	FFA:F2E01145787
42 × 48	8	6.6	4	5	5	6	73	57	260	12	100	118	0.03	FFA:F2E01145788	FFA:F2E01145789
45 × 52	10	8.6	4	5	5	6	106	-	390	17	100	119	0.05	FFA:F2E01145790	-
48 × 55	10	8.6	4	5	5	6	107	-	430	18	100	115	0.05	FFA:F2E01145791	-
50 × 57	10	8.6	4	5	5	6	110	87	470	19	100	116	0.05	FFA:F2E01145792	FFA:F2E01145793
55 × 62	10	8.6	4	5	5	6	119	97	580	21	100	118	0.05	FFA:F2E01145794	FFA:F2E01145795
56 × 64	12	10.4	4	5	5	6	151	-	740	24	100	120	0.07	FFA:F2E01145796	-
60 × 68	12	10.4	4	5	6	7	156	-	840	28	100	119	0.07	FFA:F2E01145797	-
63 × 71	12	10.4	4	5	6	7	160	-	920	29	100	118	0.08	FFA:F2E01145798	-
65 × 73	12	10.4	4	5	6	7	167	-	1 000	30	100	121	0.08	FFA:F2E01145799	-
70 × 79	14	12.2	4	5	6	7	202	171	1 300	38	100	115	0.11	FFA:F2E01145800	FFA:F2E01145801
71 × 80	14	12.2	4	5	6	7	212	-	1 400	39	100	121	0.11	FFA:F2E01145802	-
75 × 84	14	12.2	4	5	6	7	218	-	1 500	41	100	116	0.12	FFA:F2E01145803	-
80 × 91	17	15	5	6	7	8	289	242	2 100	54	100	116	0.12	FFA:F2E01145804	FFA:F2E01145805

↗ For online configuration on flender.com, click on the item no.

FASTEX IN110

non-self-centering with axial hub displacement,
for shaft diameters from 85 to 500 mm

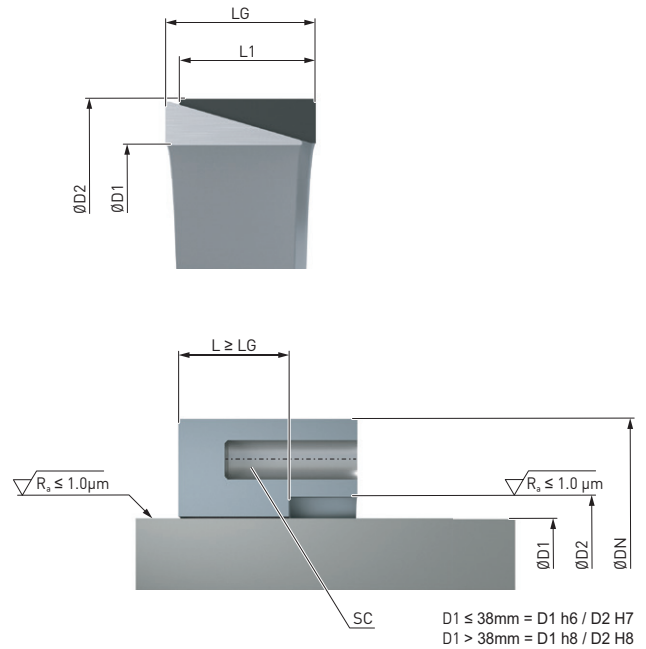

Hub exemplary applications

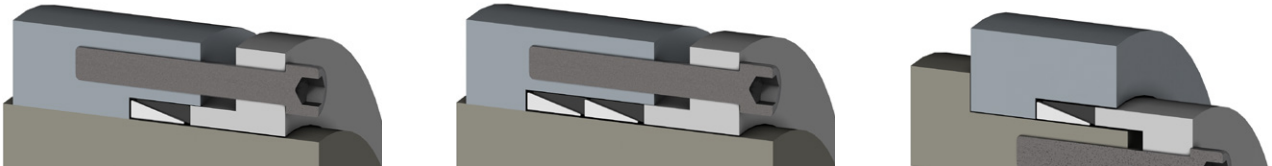

Pressure flange exemplary applications

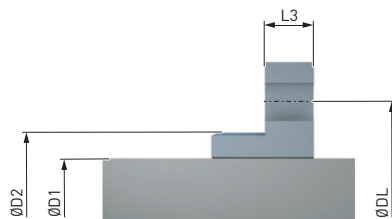
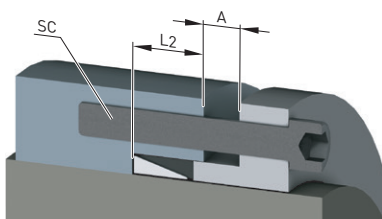

Recommended dimensions of the pressure flange in mm:

$$L2 \geq 1.5 \cdot LG$$

$$DL = D2 + 12 + SC$$

$$L3 = 1.3 \cdot SC \text{ (for screws 8.8)}$$

$$L3 = 1.8 \cdot SC \text{ (for screws 10.9/12.9)}$$

Notes

- Temperature range -20 to 160 °C
- Suitable for individual clamping connections
- Up to 4 clamping elements can be installed one after the other
- Recommended shaft tolerances h6 (D1 ≤ 38 mm), h8 (D1 > 38 mm) with a surface quality of Ra ≤ 1.0 µm
- Recommended bore tolerance H7 (D1 ≤ 38 mm), H8 (D1 > 38 mm) with a surface quality of Ra ≤ 1.0 µm

Ordering example

- FASTEX IN110 internal clamping set, size 150 x 168, standard

Article no.: FFA:F2E01145820

Size D1 × D2 mm	Dimensions		Clearance				Clamping connection				Surface pressure		Weight m kg	↗ Article no. ¹⁾	
	LG mm	L1 mm	A at number clamping elements				F _{Pre} Standard kN	slotted kN	T _{CL} Nm	F _a kN	P _{SN} N/ mm ²	P _{SW} N/ mm ²		Standard	slotted
			1 mm	2 mm	3 mm	4 mm									
85 × 96	17	15	5	6	7	8	305	260	2 400	57	100	117	0.20	FFA:F2E01145806	FFA:F2E01145807
90 × 101	17	15	5	6	7	8	319	276	2 700	61	100	118	0.20	FFA:F2E01145808	FFA:F2E01145809
95 × 106	17	15	5	6	8	9	331	-	3 000	64	100	118	0.22	FFA:F2E01145810	-
100 × 114	21	18.7	5	6	8	9	447	386	4 200	84	100	119	0.40	FFA:F2E01145811	FFA:F2E01145812
110 × 124	21	18.7	5	6	8	9	458	393	4 700	86	90	110	0.40	FFA:F2E01145813	FFA:F2E01145814
120 × 134	21	18.7	5	6	8	9	451	391	5 100	88	90	100	0.50	FFA:F2E01145815	FFA:F2E01145816
130 × 148	28	25.3	6	7	9	11	669	-	8 100	125	90	101	0.85	FFA:F2E01145817	-
140 × 158	28	25.3	6	7	9	11	707	618	9 400	135	90	101	0.91	FFA:F2E01145818	FFA:F2E01145819
150 × 168	28	25.3	6	7	9	11	758	-	11 000	145	90	103	0.97	FFA:F2E01145820	-
160 × 178	28	25.3	6	7	9	11	912	833	14 500	180	105	119	1.02	FFA:F2E01145821	FFA:F2E01145822
170 × 191	33	30	7	8	10	12	1 172	-	19 500	228	105	119	1.50	FFA:F2E01145823	-
180 × 201	33	30	7	8	10	12	1 194	1 083	21 200	235	105	116	1.60	FFA:F2E01145824	FFA:F2E01145825
190 × 211	33	30	7	9	10	12	1 272	-	24 100	250	110	118	1.70	FFA:F2E01145826	-
200 × 224	38	34.5	7	9	11	13	1 558	1 425	31 000	310	105	118	2.30	FFA:F2E01145827	FFA:F2E01145828
210 × 234	38	34.5	7	9	11	13	1 659	-	35 000	332	109	121	2.50	FFA:F2E01145829	-
220 × 244	38	34.5	7	9	11	13	1 709	1 588	38 000	344	108	120	2.50	FFA:F2E01145830	FFA:F2E01145831
230 × 257	43	39.5	7	9	12	14	1 744	-	39 500	242	90	100	3.40	FFA:F2E01145832	-
240 × 267	43	39.5	7	9	12	14	1 960	1 800	47 000	391	99	110	3.50	FFA:F2E01145833	FFA:F2E01145834
250 × 280	48	44	8	10	13	16	2 100	-	52 000	415	90	100	4.70	FFA:F2E01145835	FFA:F2E01203615
260 × 290	48	44	8	10	13	16	2 178	2 000	56 500	435	90	100	4.80	FFA:F2E01145836	FFA:F2E01145837
270 × 300	48	44	8	10	13	16	2 250	-	61 000	450	90	100	4.90	FFA:F2E01145838	-
280 × 313	53	49	9	11	14	17	2 586	2 380	72 500	518	90	100	6.30	FFA:F2E01145839	FFA:F2E01145840
290 × 323	53	49	9	11	14	17	2 678	-	77 500	534	90	100	6.50	FFA:F2E01145841	-
300 × 333	53	49	9	11	14	17	2 758	-	83 000	553	90	100	6.70	FFA:F2E01145842	-
320 × 360	65	59	10	15	20	25	3 566	3 275	114 000	719	89	100	10.90	FFA:F2E01145843	FFA:F2E01145844
340 × 380	65	59	10	15	20	25	3 749	-	128 500	778	89	100	11.50	FFA:F2E01145845	-
360 × 400	65	59	10	15	20	25	3 938	3 677	144 000	800	87	100	12.20	FFA:F2E01145846	FFA:F2E01145847
380 × 420	65	59	10	15	20	25	4 139	3 871	160 000	845	90	100	12.80	FFA:F2E01145848	FFA:F2E01145849
400 × 440	65	59	10	15	20	25	4 347	4 095	178 000	890	91	100	13.50	FFA:F2E01145850	FFA:F2E01145851
420 × 460	65	59	10	15	20	25	4 534	-	196 000	933	91	100	14.10	FFA:F2E01145852	-
440 × 480	65	59	10	15	20	25	4 726	-	215 000	977	92	100	14.70	FFA:F2E01145853	-
460 × 500	65	59	10	15	20	25	4 920	-	235 000	1 022	92	100	15.30	FFA:F2E01145854	-
480 × 520	65	59	10	15	20	25	5 141	-	256 000	1 070	92	100	16.00	FFA:F2E01145855	-
500 × 540	65	59	10	15	20	25	5 340	-	278 000	1 112	93	100	16.60	FFA:F2E01145856	-

↗ For online configuration on flender.com, click on the item no.

FASTEX IN220

non-self-centering without axial hub displacement

1

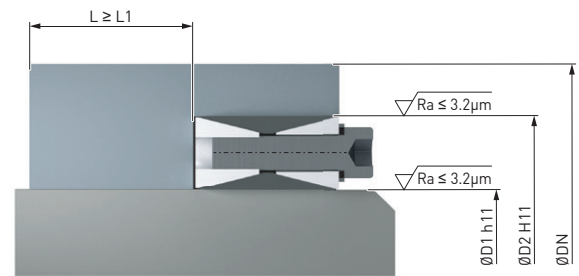
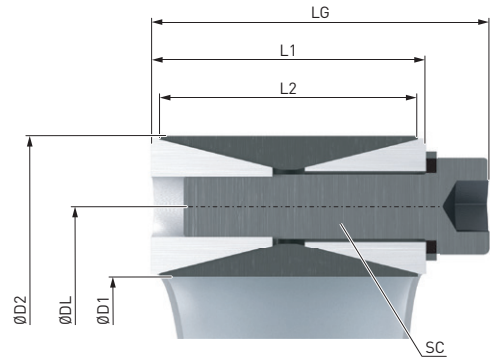

Hub exemplary applications

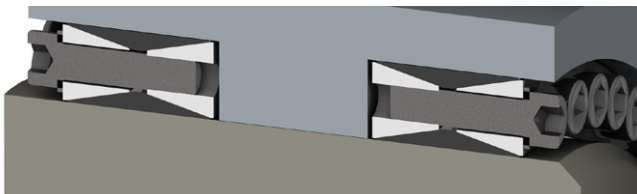
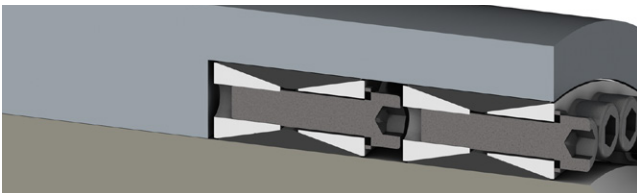
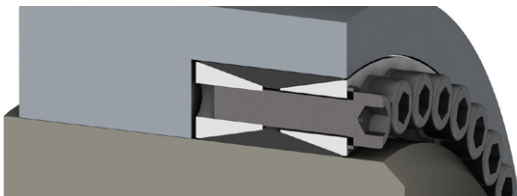

Notes

- Temperature range -20 to 160 °C
- Recommended shaft tolerances k11-h11 with a surface quality of $Ra \leq 3.2 \mu m$
- Recommended bore tolerance N11-H11 with a surface quality of $Ra \leq 3.2 \mu m$

Ordering example

- FASTEX IN220 internal clamping set, size 40 x 65

Article no.: FFA:F2E01145869

Size D1 × D2 mm	Dimensions			Screw DIN EN ISO 4762 – 12.9				Surface pressure		Weight m kg	↗ Article no. ²⁾
	L _G mm	L ₁ mm	L ₂ mm	SC	T _A ¹⁾ Nm	T _{CL} Nm	F _a kN	P _{SN} N/mm ²	P _{SW} N/mm ²		
17 × 47	26	20	17	M6	16	260	31	104	287	0.21	FFA:F2E01145857
18 × 47	26	20	17	M6	16	280	31	104	271	0.21	FFA:F2E01145858
19 × 47	26	20	17	M6	16	290	31	104	257	0.21	FFA:F2E01145859
20 × 47	26	20	17	M6	16	310	31	104	244	0.22	FFA:F2E01145860
22 × 47	26	20	17	M6	16	340	31	104	222	0.22	FFA:F2E01145861
24 × 50	26	20	17	M6	16	370	31	98	203	0.25	FFA:F2E01145862
25 × 50	26	20	17	M6	16	390	31	98	195	0.25	FFA:F2E01145863
28 × 55	26	20	17	M6	16	650	46	133	261	0.27	FFA:F2E01145864
30 × 55	26	20	17	M6	16	700	47	133	244	0.25	FFA:F2E01145865
32 × 60	26	20	17	M6	16	750	47	122	229	0.30	FFA:F2E01145866
35 × 60	26	20	17	M6	16	820	47	122	209	0.28	FFA:F2E01145867
38 × 65	26	20	17	M6	16	1 100	58	141	241	0.35	FFA:F2E01145868
40 × 65	26	20	17	M6	16	1 170	59	141	229	0.31	FFA:F2E01145869
42 × 75	32	24	20	M8	40	1 670	80	145	254	0.56	FFA:F2E01145870
45 × 75	32	24	20	M8	40	1 790	80	145	237	0.52	FFA:F2E01145871
48 × 80	32	24	20	M8	40	1 900	79	136	222	0.60	FFA:F2E01145872
50 × 80	32	24	20	M8	40	1 990	80	136	213	0.57	FFA:F2E01145873
55 × 85	32	24	20	M8	40	2 740	100	160	242	0.62	FFA:F2E01145874
60 × 90	32	24	20	M8	40	2 990	100	151	222	0.66	FFA:F2E01145875
65 × 95	32	24	20	M8	40	3 240	100	143	205	0.80	FFA:F2E01145876
70 × 110	38	28	24	M10	78	5 550	159	160	250	1.30	FFA:F2E01145877
75 × 115	38	28	24	M10	78	5 950	159	153	234	1.24	FFA:F2E01145878
80 × 120	38	28	24	M10	78	6 350	159	146	220	1.36	FFA:F2E01145879
85 × 125	38	28	24	M10	78	6 740	159	140	207	1.43	FFA:F2E01145880
90 × 130	38	28	24	M10	78	7 140	159	135	195	1.46	FFA:F2E01145881
95 × 135	38	28	24	M10	78	9 000	189	156	221	1.57	FFA:F2E01145882
100 × 145	44	32	26	M12	135	11 600	232	164	237	2.15	FFA:F2E01145883
105 × 155	44	32	26	M12	135	12 200	232	153	226	2.40	FFA:F2E01145884
110 × 155	44	32	26	M12	135	12 750	232	153	215	2.30	FFA:F2E01145885
120 × 165	44	32	26	M12	135	14 800	247	153	211	2.40	FFA:F2E01145886
130 × 180	50	38	34	M12	135	20 150	310	134	186	3.50	FFA:F2E01145887
140 × 190	50	38	34	M12	135	23 850	341	140	190	3.80	FFA:F2E01145888
150 × 200	50	38	34	M12	135	27 850	371	145	194	4.00	FFA:F2E01145889
160 × 210	50	38	34	M12	135	32 200	403	150	197	4.36	FFA:F2E01145890
170 × 225	58	44	38	M14	215	40 300	475	148	195	5.70	FFA:F2E01145891
180 × 235	58	44	38	M14	215	46 600	518	154	201	6.00	FFA:F2E01145892
190 × 250	66	52	49	M14	215	57 300	604	139	183	8.00	FFA:F2E01145893
200 × 260	66	52	49	M14	215	71 000	711	158	205	8.20	FFA:F2E01145894
220 × 285	72	56	50	M16	335	93 200	849	158	205	11.00	FFA:F2E01145895
240 × 305	72	56	50	M16	335	117 300	979	170	216	12.20	FFA:F2E01145896
260 × 325	72	56	50	M16	335	144 000	1 110	181	226	13.20	FFA:F2E01145897
280 × 355	84	66	60	M18	465	177 700	1 271	158	201	19.20	FFA:F2E01145898
300 × 375	84	66	60	M18	465	214 100	1 430	168	211	20.50	FFA:F2E01145899
320 × 405	98	78	72	M20	660	295 800	1 852	168	213	29.60	FFA:F2E01145900
340 × 425	98	78	72	M20	660	314 300	1 852	160	201	31.10	FFA:F2E01145901
360 × 455	112	90	84	M22	900	413 300	2 300	159	202	42.20	FFA:F2E01145902
380 × 475	112	90	84	M22	900	436 300	2 300	153	191	44.00	FFA:F2E01145903
400 × 495	112	90	84	M22	900	459 300	2 300	147	181	46.00	FFA:F2E01145904
420 × 515	112	90	84	M22	900	535 800	2 555	157	192	50.00	FFA:F2E01145905
440 × 545	130	102	96	M24	1 130	647 600	2 948	149	185	64.60	FFA:F2E01145906
460 × 565	130	102	96	M24	1 130	677 000	2 948	144	177	67.40	FFA:F2E01145907
480 × 585	130	102	96	M24	1 130	741 800	3 096	146	178	71.00	FFA:F2E01145908
500 × 605	130	102	96	M24	1 130	809 500	3 243	148	179	72.60	FFA:F2E01145909
520 × 630	130	102	96	M24	1 130	861 000	3 317	145	176	80.00	FFA:F2E01145910

¹⁾ The specified tightening torques T_A are the maximum values. The tightening torque can be reduced by max. 40% to proportionally reduce the transmissible torque T_{CL}, the transmissible axial force F_a and the surface pressures P_{SN} and P_{SW}.

↗ For online configuration on flender.com, click on the item no.

CLAMPING ELEMENTS

FASTEX EXTERNAL CLAMPING SETS



FASTEX EC210

self-centering without axial hub displacement,
with inner diameters from 16 to 100 mm

2/2

FASTEX EC210

self-centering without axial hub displacement,
with inner diameters from 105 to 200 mm

2/4

FASTEX EC210

self-centering without axial hub displacement,
with inner diameters from 220 to 500 mm

2/6

FASTEX EC220

self-centering without axial hub displacement,
with inner diameters from 14 to 115 mm

2/8

FASTEX EC220

self-centering without axial hub displacement,
with inner diameters from 120 to 280 mm

2/10

FASTEX EC220

self-centering without axial hub displacement,
with inner diameters from 300 to 500 mm

2/12

FASTEX EC210

self-centering without axial hub displacement,
with inner diameters from 16 to 100 mm

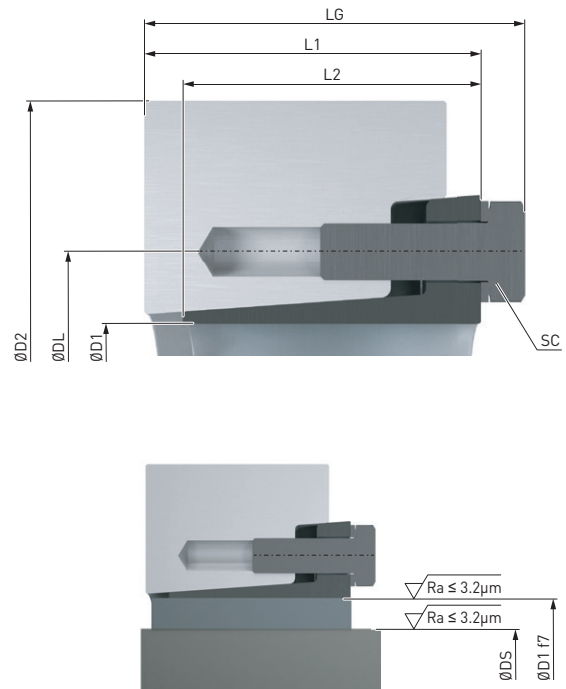

Hub exemplary applications

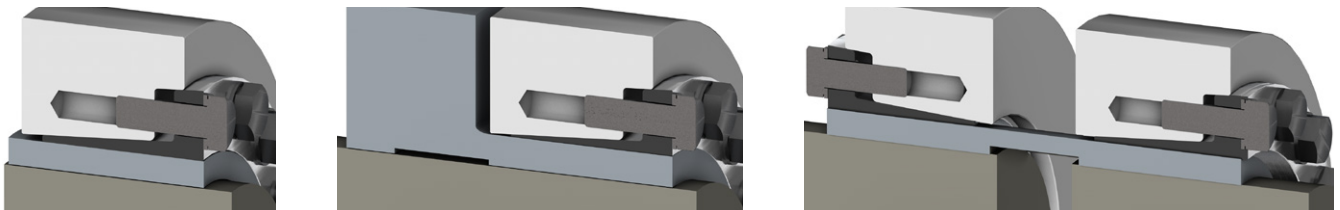

Notes

- Temperature range -20 to 160 °C
- 2-part
- Resistant to dirt due to closed design
- Recommended shaft tolerances h6 (DS ≤ 160 mm), g6 (DS > 160 mm) with a surface quality of Ra ≤ 3.2 µm
- Recommended bore tolerance H7 with a surface quality of Ra ≤ 3.2 µm

Ordering example

- FASTEX EC210 external clamping set, size 30 x 60

Article no.: FFA:F2E01152038

Size D1 × D2 mm	Dimensions					Screw DIN EN ISO 4017 – 12.9				Surface pressure P_{SH} N/mm ²	Weight <i>m</i> kg	↗ Article no. ²⁾
	DS mm	LG mm	L1 mm	L2 mm	DL mm	SC	T_A ¹⁾ Nm	T_{CL} Nm	F_a kN			
16 × 41	13	19.5	15.5	13.5	28	M6	13	70	11	231	0.1	FFA:F2E01152033
	14							90	13			
18 × 44	15	19.5	15.5	13.5	30	M6	13	80	11	210	0.1	FFA:F2E01152034
	16							110	14			
20 × 47	17	19.5	15.5	13.5	32	M6	13	150	18	233	0.1	FFA:F2E01152035
	18							180	20			
24 × 50	19	22	18	16	36	M6	13	165	17	295	0.2	FFA:F2E01152036
	20							225	23			
	22							295	27			
26 × 51.5	20	22	18	16	38	M6	13	230	23	244	0.2	FFA:F2E01152037
	22							300	27			
	24							350	29			
30 × 60	24	24	20	18	44	M6	13	370	31	240	0.3	FFA:F2E01152038
	25							420	34			
	26							470	36			
36 × 72	27	27.5	22	20	52	M8	30	480	36	274	0.5	FFA:F2E01152039
	30							650	43			
	33							860	52			
38 × 72	27	27.5	22	20	54	M8	30	480	36	267	0.5	FFA:F2E01152040
	30							650	43			
	33							860	52			
40 × 80	34	29.5	24	22	61	M8	30	880	52	211	0.6	FFA:F2E01152041
	35							810	46			
44 × 80	37	29.5	24	22	61	M8	30	960	52	222	0.6	FFA:F2E01152042
	38							1 150	61			
50 × 90	40	31.5	26	23.5	68	M8	30	1 300	65	240	0.8	FFA:F2E01152043
	42							1 520	72			
	42							1 300	62			
55 × 100	45	34.5	29	26	72	M8	30	1 600	71	195	1.1	FFA:F2E01152044
	48							1 900	79			
	48							1 700	71			
60 × 110	50	34.5	29	26	80	M8	30	1 950	78	183	1.3	FFA:F2E01152045
	52							2 160	83			
	48							1 700	71			
62 × 110	50	34.5	29	26	80	M8	30	1 950	78	200	1.3	FFA:F2E01152046
	52							2 160	83			
	50							1 900	76			
68 × 115	55	35	29.5	26	86	M8	30	2 500	91	196	1.3	FFA:F2E01152047
	60							3 150	105			
	55							2 700	105			
75 × 138	60	37.5	31	27	100	M10	60	3 400	120	228	2.3	FFA:F2E01152048
	65							4 100	132			
	60							3 300	110			
80 × 141	65	37.5	31	27	104	M10	60	4 100	126	249	2.3	FFA:F2E01152049
	70							4 950	141			
	65							5 500	169			
85 × 155	70	44.5	38	34	114	M10	60	6 600	189	211	3.2	FFA:F2E01152050
	75							7 900	211			
	65							5 500	169			
90 × 155	70	44.5	38	34	114	M10	60	6 600	189	224	3.2	FFA:F2E01152051
	75							7 900	211			
	70							6 200	186			
95 × 170	75	50	43.5	39	124	M10	60	7 400	197	212	4.3	FFA:F2E01152052
	80							8 600	215			
	70							6 200	186			
100 × 170	75	50	43.5	39	124	M10	60	7 400	197	222	4.3	FFA:F2E01152053
	80							8 600	215			

¹⁾ The specified tightening torques T_A are the maximum values. The tightening torque can be reduced by max. 40% to proportionally reduce the transmissible torque T_{CL} , the transmissible axial force F_a and the surface pressures P_{SN} and P_{SW} .

↗ For online configuration on flender.com, click on the item no.

FASTEX EC210

self-centering without axial hub displacement,
with inner diameters from 105 to 200 mm

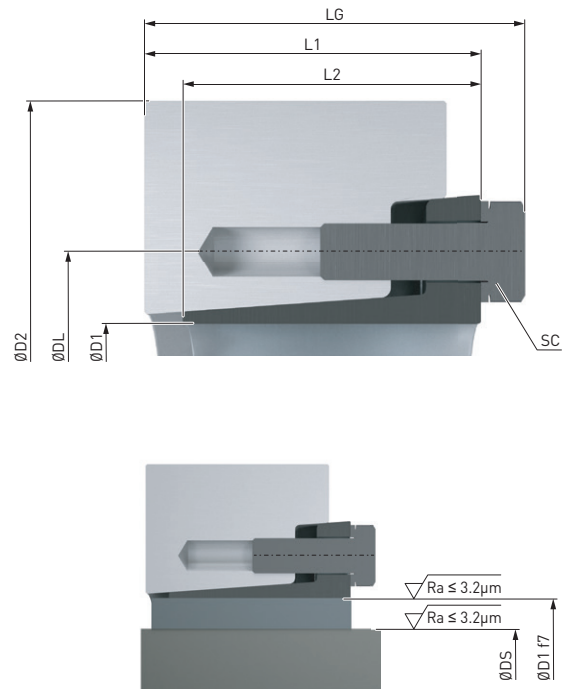

Hub exemplary applications

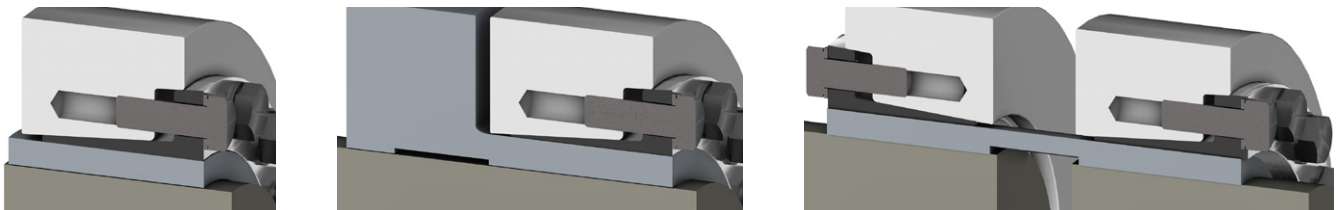

Notes

- Temperature range -20 to 160 °C
- 2-part
- Resistant to dirt due to closed design
- Recommended shaft tolerances h6 (DS ≤ 160 mm), g6 (DS > 160 mm) with a surface quality of Ra ≤ 3.2 μm
- Recommended bore tolerance H7 with a surface quality of Ra ≤ 3.2 μm

Ordering example

- FASTEX EC210 external clamping set, size 140 x 230

Article no.: FFA:F2E01152062

Size D1 × D2 mm	Dimensions					Screw DIN EN ISO 4017 – 12.9				Surface pressure P_{SH} N/mm ²	Weight <i>m</i> kg	↗ Article no. ²⁾
	DS mm	LG mm	L1 mm	L2 mm	DL mm	SC	T_A ¹⁾ Nm	T_{CL} Nm	F_a kN			
105 × 185	80	56.5	49	43.5	136	M12	100	10 500	263	203	5.8	FFA:F2E01152054
	85							11 800	278			
	90							13 700	304			
110 × 185	80	56.5	49	43.5	136	M12	100	10 500	263	217	5.8	FFA:F2E01152055
	85							11 800	278			
	90							13 700	304			
115 × 197	85	60.5	53	48	147	M12	100	12 500	294	208	6.9	FFA:F2E01152056
	90							14 100	313			
	95							16 000	337			
120 × 197	85	60.5	53	48	147	M12	100	12 500	294	216	6.9	FFA:F2E01152057
	90							14 100	313			
	95							16 000	337			
125 × 215	90	61	53.5	48	158	M12	100	14 500	322	218	8.7	FFA:F2E01152058
	95							16 600	349			
	100							18 800	376			
130 × 215	95	61	53.5	48	158	M12	100	17 000	358	225	9.4	FFA:F2E01152059
	100							18 400	368			
	110							22 000	400			
130 × 230	95	66.5	57.5	51	165	M14	160	18 400	387	229	10.8	FFA:F2E01152060
	100							20 800	416			
	110							26 200	476			
135 × 230	95	66.5	57.5	51	165	M14	160	18 400	387	236	10.8	FFA:F2E01152061
	100							20 800	416			
	110							26 200	476			
140 × 230	100	67	58	51	172	M14	160	19 900	398	246	10.3	FFA:F2E01152062
	105							22 200	423			
	115							27 800	483			
150 × 263	110	71	62	55	186	M14	160	27 000	491	239	15.2	FFA:F2E01152063
	120							32 000	533			
	125							36 200	579			
155 × 263	110	71	62	55	186	M14	160	27 000	491	249	15.2	FFA:F2E01152064
	120							32 000	533			
	125							36 200	579			
160 × 290	120	78.5	68.5	61	198	M16	250	39 000	650	265	21.5	FFA:F2E01152065
	130							48 000	738			
	135							51 000	756			
165 × 290	120	78.5	68.5	61	198	M16	250	39 000	650	271	21.5	FFA:F2E01152066
	130							48 000	738			
	135							51 000	756			
170 × 300	130	79	69	61	208	M16	250	46 500	715	264	22.5	FFA:F2E01152067
	140							53 000	757			
	145							59 000	814			
175 × 300	130	79	69	61	208	M16	250	46 500	715	269	22.5	FFA:F2E01152068
	140							53 000	757			
	145							59 000	814			
180 × 320	140	95	85	77.5	222	M16	250	66 000	943	257	32.7	FFA:F2E01152069
	150							76 000	1 013			
	155							83 000	1 071			
185 × 320	140	95	85	77.5	222	M16	250	66 000	943	242	32.7	FFA:F2E01152070
	150							76 000	1 013			
	155							83 000	1 013			
190 × 340	150	98	88	77.5	238	M16	250	82 000	1 093	266	38.3	FFA:F2E01152071
	160							91 000	1 138			
	165							102 000	1 236			
195 × 340	150	98	88	77.5	238	M16	250	82 000	1 093	263	37.3	FFA:F2E01152072
	160							91 000	1 138			
	165							102 000	1 236			
200 × 340	150	98	88	77.5	238	M16	250	82 000	1 093	262	36.3	FFA:F2E01152073
	160							91 000	1 138			
	165							102 000	1 236			

¹⁾ The specified tightening torques T_A are the maximum values. The tightening torque can be reduced by max. 40% to proportionally reduce the transmissible torque T_{CL} , the transmissible axial force F_a and the surface pressures P_{SN} and P_{SW} .

↗ For online configuration on flender.com, click on the item no.

FASTEX EC210

self-centering without axial hub displacement,
with inner diameters from 220 to 500 mm

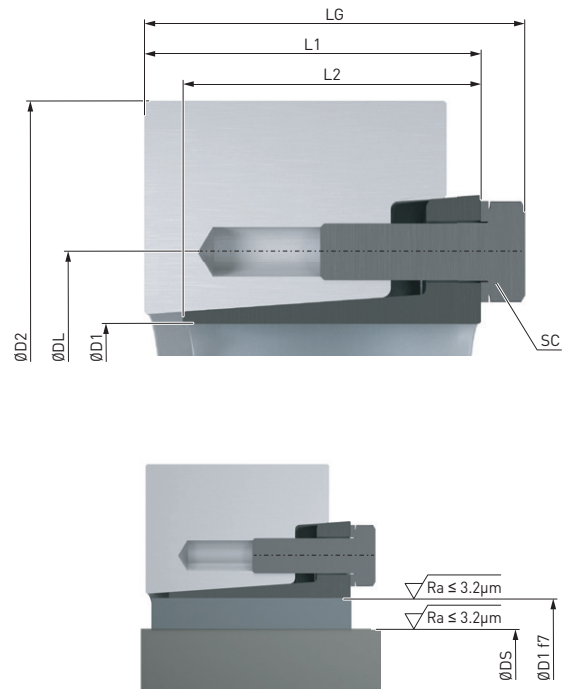
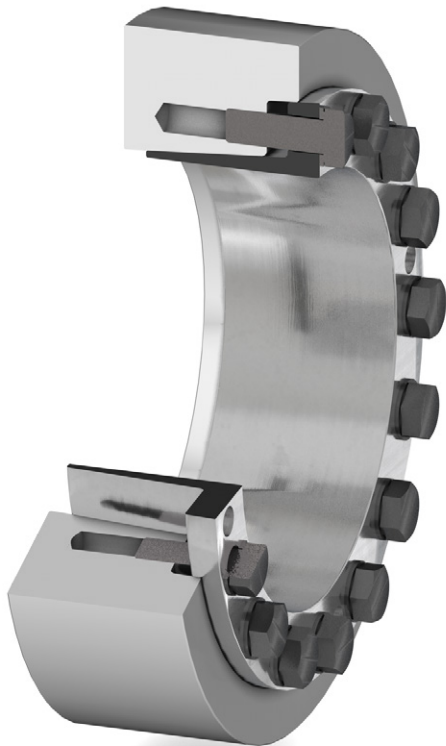

Hub exemplary applications

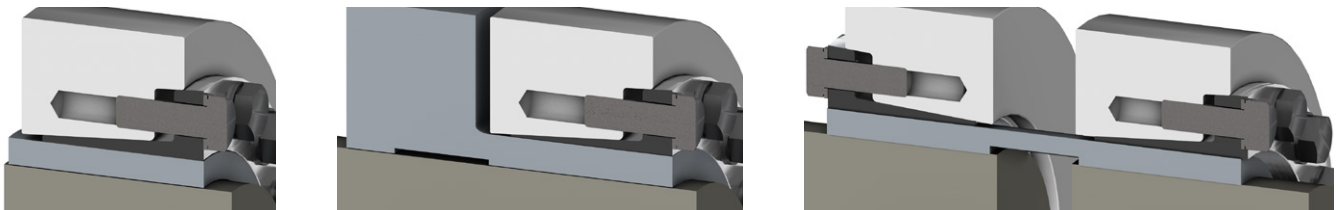

Notes

- Temperature range -20 to 160 °C
- 2-part
- Resistant to dirt due to closed design
- Recommended shaft tolerances h6 (DS ≤ 160 mm), g6 (DS > 160 mm) with a surface quality of Ra ≤ 3.2 µm
- Recommended bore tolerance H7 with a surface quality of Ra ≤ 3.2 µm

Ordering example

- FASTEX EC210 external clamping set, size 360 x 590

Article no.: FFA:F2E01152081

Size D1 × D2 mm	Dimensions					Screw DIN EN ISO 4017 – 12.9				Surface pressure P_{SH} N/mm ²	Weight <i>m</i> kg	➤ Article no. ²⁾
	DS mm	LG mm	L1 mm	L2 mm	DL mm	SC	T_A ¹⁾ Nm	T_{CL} Nm	F_a kN			
220 × 370	160	120	107.5	96.5	268	M20	480	105 000	1 313	281	53	FFA:F2E01152074
	170							122 000	1 435			
	180							138 000	1 533			
240 × 405	170	123.5	111	98	288	M20	480	125 000	1 471	274	66	FFA:F2E01152075
	180							145 000	1 611			
	200							182 000	1 820			
260 × 430	190	138	125.5	110.5	312	M20	480	165 000	1 737	247	82	FFA:F2E01152076
	200							190 000	1 900			
	220							238 000	2 164			
280 × 460	210	152.5	140	121	334	M20	480	220 000	2 095	237	103	FFA:F2E01152077
	220							245 000	2 227			
	240							300 000	2 500			
300 × 485	220	159	140	124	360	M24	840	297 000	2 700	298	120	FFA:F2E01152078
	230							330 000	2 870			
	250							399 000	3 192			
320 × 520	240	160.5	141.5	124	380	M24	840	331 000	2 758	320	138	FFA:F2E01152079
	250							365 000	2 920			
	270							437 000	3 237			
340 × 570	250	177.5	158.5	139	402	M24	840	429 000	3 432	297	189	FFA:F2E01152080
	260							469 000	3 608			
	280							556 000	3 971			
360 × 590	270	182	163	143	424	M24	840	545 000	4 037	300	207	FFA:F2E01152081
	280							592 000	4 229			
	290							694 000	4 786			
390 × 650	290	191	169	148	454	M27	1 250	704 000	4 855	331	249	FFA:F2E01152082
	300							760 000	5 067			
	320							879 000	5 494			
420 × 670	320	208	186	166	486	M27	1 250	827 000	5 169	292	285	FFA:F2E01152083
	330							876 000	5 309			
	350							1 000 000	5 714			
440 × 710	340	220	198	179	506	M27	1 250	1 117 000	6 571	251	343	FFA:F2E01152084
	350							1 190 000	6 800			
	370							1 345 000	7 270			
460 × 750	360	223	201	179	534	M27	1 250	1 306 000	7 256	260	387	FFA:F2E01152085
	370							1 386 000	7 492			
	390							1 554 000	7 969			
470 × 705	370	241.5	220	200	538	M27	1 250	950 000	5 135	163	340	FFA:F2E01152086
	380							1 000 000	5 263			
	400							1 150 000	5 750			
480 × 770	380	247	223	201	552	M30	1 650	1 557 000	8 195	242	449	FFA:F2E01152087
	390							1 648 000	8 451			
	410							1 818 000	8 868			
500 × 820	400	241	217	198	572	M30	1 650	1 653 000	8 265	235	515	FFA:F2E01152088
	410							1 725 000	8 415			
	430							1 915 000	8 907			

¹⁾ The specified tightening torques T_A are the maximum values. The tightening torque can be reduced by max. 40% to proportionally reduce the transmissible torque T_{CL} , the transmissible axial force F_a and the surface pressures P_{SN} and P_{SW} .

➤ For online configuration on flender.com, click on the item no.

FASTEX EC220

self-centering without axial hub displacement,
with inner diameters from 14 to 115 mm

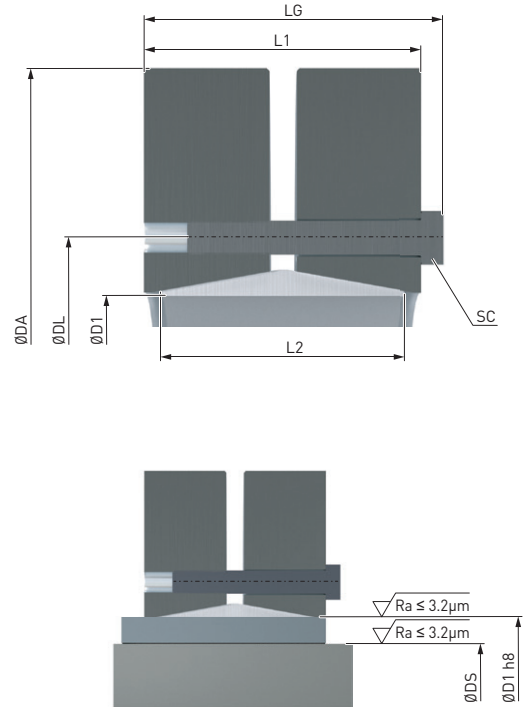
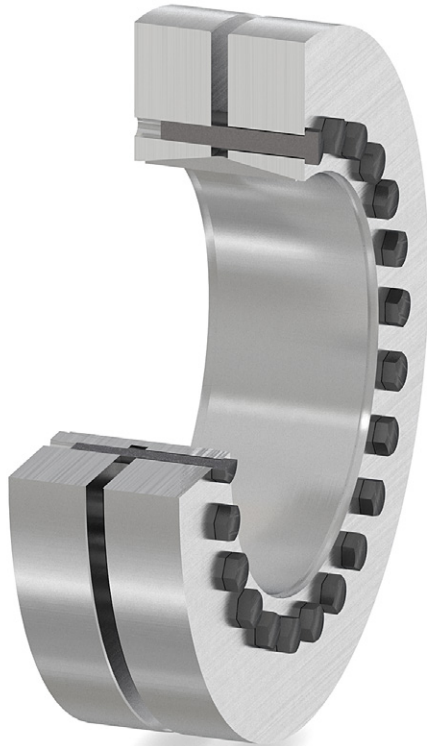

Hub exemplary applications

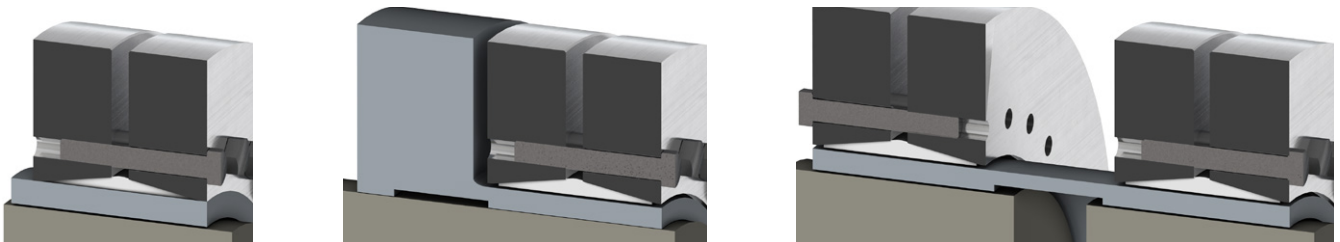

Notes

- Temperature range -20 to 160 °C
- 3-part
- Recommended shaft tolerances j6 (DS 10 - 30 mm), h6 (DS 31 - 50 mm), g6 (DS 51 - 500 mm) with a surface quality of $Ra \leq 3.2 \mu\text{m}$
- Recommended bore tolerance H6 (DS 10 - 80 mm), H7 (DS 81 - 500 mm) with a surface quality of $Ra \leq 3.2 \mu\text{m}$

Ordering example

- FASTEX EC220 external clamping set, size 30 x 60

Article no.: FFA:F2E01152019

Size D1 × D2 mm	Dimensions					Screw DIN EN ISO 4014 – 10.9				Surface pressure P_{SH} N/mm ²	Weight <i>m</i> kg	↗ Article no. ²⁾
	DS mm	LG mm	L1 mm	L2 mm	DL mm	SC	T_A ¹⁾ Nm	T_{CL} Nm	F_a kN			
14 × 38	10	14.5	11	9	24	M5	3.5	28	5	379	0.1	FFA:F2E01152014
	11							38	7			
	12							50	9			
16 × 41	12	18.5	15	11	26	M5	4	50	9	383	0.2	FFA:F2E01152015
	13							70	10			
	14							90	13			
18 × 44	14	18.5	15	12	29	M5	4	85	16	312	0.2	FFA:F2E01152016
	15							100	18			
	16							130	20			
20 × 50	15	22.5	19	14	36	M5	4	130	20	294	0.2	FFA:F2E01152017
	16							150	22			
	18							200	25			
24 × 50	19	22.5	19	14	36	M5	5	180	26	305	0.2	FFA:F2E01152018
	20							210	27			
	21							250	29			
30 × 60	24	24.5	21	16	44	M5	6	310	26	255	0.3	FFA:F2E01152019
	25							340	27			
	26							380	28			
36 × 72	28	27	23	18	52	M6	12	460	50	255	0.4	FFA:F2E01152020
	30							590	54			
	31							630	58			
44 × 80	32	29	25	20	61	M6	12	630	65	260	0.6	FFA:F2E01152021
	35							780	74			
	36							860	77			
50 × 90	38	31	27	22	70	M6	12	940	79	239	0.8	FFA:F2E01152022
	40							1 100	85			
	42							1 300	90			
55 × 100	42	34	30	23	75	M6	12	1 200	80	209	1.1	FFA:F2E01152023
	45							1 500	90			
	48							1 900	100			
62 × 110	48	34	30	23	86	M6	12	1 800	100	229	1.3	FFA:F2E01152024
	50							2 200	110			
	52							2 400	120			
68 × 115	50	34	30	23	86	M6	12	2 000	100	217	1.4	FFA:F2E01152025
	55							2 500	110			
	60							3 100	120			
75 × 138	55	37.5	32	25	100	M8	30	2 500	120	232	1.8	FFA:F2E01152026
	60							3 200	140			
	65							3 900	150			
80 × 145	60	37.5	32	25	100	M8	30	3 200	120	218	2.6	FFA:F2E01152107
	65							3 900	140			
	70							4 600	160			
85 × 155	65	44.5	39	30	114	M8	30	4 800	148	246	4	FFA:F2E01152108
	70							6 100	174			
	75							7 400	197			
90 × 155	65	44.5	39	30	114	M8	30	4 700	170	230	3.8	FFA:F2E01152109
	70							6 000	190			
	75							7 200	210			
100 × 170	70	49.5	44	34	124	M8	30	6 900	180	217	4.7	FFA:F2E01152110
	75							7 500	220			
	80							9 000	240			
110 × 185	75	56.5	50	39	136	M10	59	7 200	230	200	6	FFA:F2E01152111
	80							9 000	250			
	85							11 000	260			
115 × 188	80	56.5	50	39	141	M10	59	8 500	210	202	5	FFA:F2E01152112
	85							10 000	240			
	90							12 000	270			

¹⁾ The specified tightening torques T_A are the maximum values. The tightening torque can be reduced by max. 40% to proportionally reduce the transmissible torque T_{CL} , the transmissible axial force F_a and the surface pressures P_{SN} and P_{SW} .

↗ For online configuration on flender.com, click on the item no.

FASTEX EC220

self-centering without axial hub displacement,
with inner diameters from 120 to 280 mm

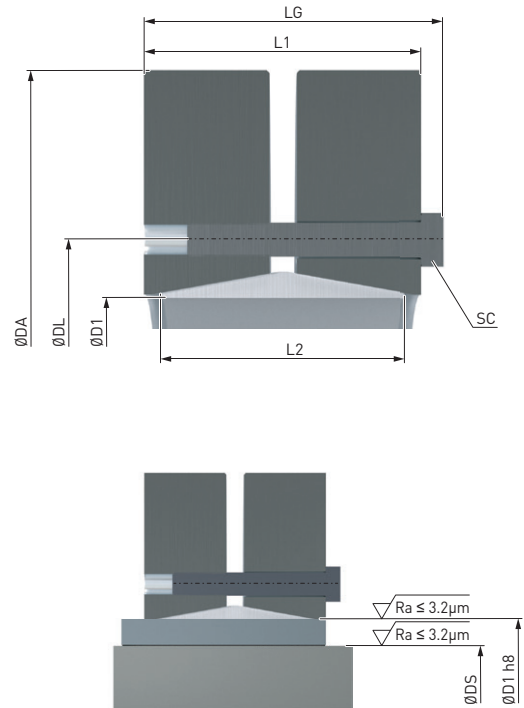
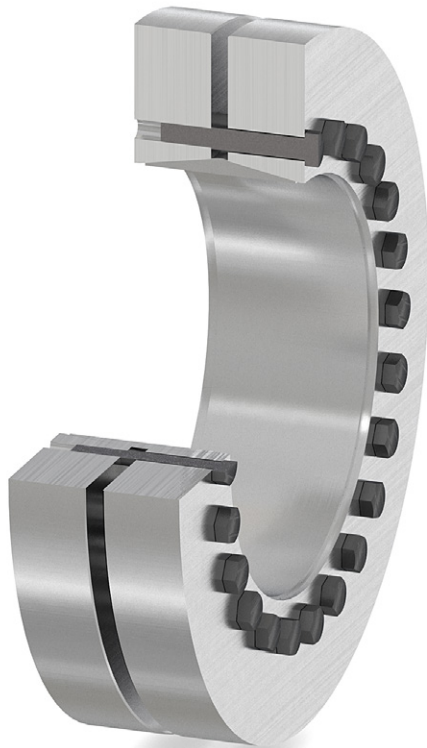

Hub exemplary applications

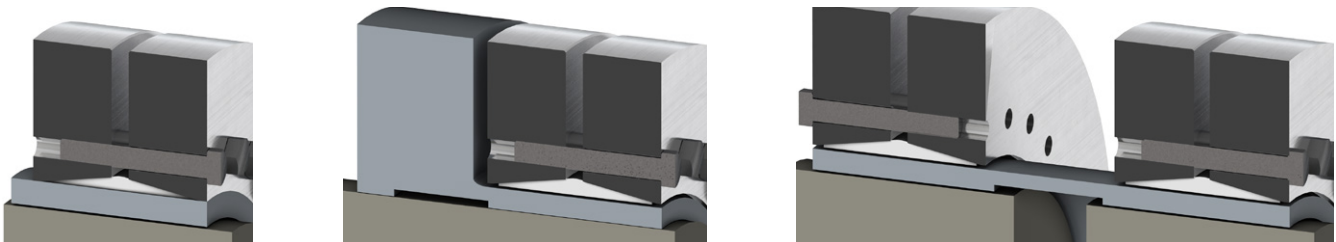

Notes

- Temperature range -20 to 160 °C
- 3-part
- Recommended shaft tolerances j6 (DS 10 - 30 mm), h6 (DS 31 - 50 mm), g6 (DS 51 - 500 mm) with a surface quality of $Ra \leq 3.2 \mu\text{m}$
- Recommended bore tolerance H6 (DS 10 - 80 mm), H7 (DS 81 - 500 mm) with a surface quality of $Ra \leq 3.2 \mu\text{m}$

Ordering example

- FASTEX EC220 external clamping set, size 160 x 265

Article no.: FFA:F2E01152118

Size D1 × D2 mm	Dimensions					Screw DIN EN ISO 4014 – 10.9				Surface pressure P_{SH} N/mm ²	Weight <i>m</i> kg	↗ Article no. ²⁾
	DS mm	LG mm	L1 mm	L2 mm	DL mm	SC	T_A ¹⁾ Nm	T_{CL} Nm	F_a kN			
120 × 215	80	58.5	52	42	160	M10	59	10 500	280	238	5.9	FFA:F2E01152113
	85							13 200	300			
	90							14 400	330			
125 × 215	85	58.5	52	42	160	M10	59	11 000	300	218	8.5	FFA:F2E01152114
	90							13 000	320			
	95							15 000	350			
130 × 215	90	58.5	52	42	160	M10	59	13 700	300	214	9	FFA:F2E01152115
	95							15 800	330			
	100							18 200	360			
140 × 230	95	67.5	60	46	175	M12	100	15 000	360	211	11	FFA:F2E01152116
	100							17 000	400			
	105							20 000	420			
155 × 265	105	71.5	64	50	192	M12	100	20 000	390	210	15	FFA:F2E01152117
	110							23 000	420			
	115							26 000	450			
160 × 265	110	71.5	64	50	192	M12	100	22 500	410	204	14	FFA:F2E01152118
	115							25 500	440			
	120							28 600	470			
165 × 290	115	81	71	56	210	M16	250	36 000	630	227	25	FFA:F2E01152119
	120							39 000	660			
	125							44 000	700			
170 × 290	120	81	71	56	210	M16	250	31 700	600	220	24	FFA:F2E01152120
	125							35 800	630			
	130							40 000	660			
175 × 300	125	81	71	56	220	M16	250	40 000	650	230	27	FFA:F2E01152121
	130							44 000	680			
	135							49 000	720			
180 × 300	130	81	71	56	220	M16	250	36 800	560	209	26	FFA:F2E01152122
	135							42 000	620			
	140							46 000	650			
185 × 330	135	96	86	71	236	M16	250	55 000	815	209	36	FFA:F2E01152123
	140							60 000	875			
	145							65 000	896			
190 × 330	140	96	86	71	236	M16	250	53 300	790	198	35	FFA:F2E01152124
	145							58 500	830			
	150							63 500	870			
195 × 350	140	96	86	71	246	M16	250	66 000	950	232	38	FFA:F2E01152125
	150							76 000	1 000			
	155							82 000	1 100			
200 × 350	150	96	86	71	246	M16	250	73 700	980	227	41	FFA:F2E01152126
	155							79 800	1 000			
	160							85 800	1 070			
220 × 370	160	114	104	88	270	M16	250	95 000	1 200	207	54	FFA:F2E01152127
	165							102 000	1 300			
	170							110 000	1 300			
240 × 405	170	121.5	109	92	295	M20	490	120 000	1 500	229	67	FFA:F2E01152128
	180							140 000	1 600			
	190							160 000	1 700			
250 × 405	180	120.5	108	92	295	M20	490	160 000	1 600	257	64	FFA:F2E01152129
	190							180 000	1 700			
	200							200 000	1 800			
260 × 430	190	132.5	120	103	321	M20	490	165 000	1 760	221	82	FFA:F2E01152130
	200							185 000	1 878			
	210							204 000	2 008			
280 × 460	210	146.5	134	114	346	M20	490	216 000	2 085	212	102	FFA:F2E01152131
	220							245 000	2 220			
	230							270 000	2 350			

¹⁾ The specified tightening torques T_A are the maximum values. The tightening torque can be reduced by max. 40% to proportionally reduce the transmissible torque T_{CL} , the transmissible axial force F_a and the surface pressures P_{SN} and P_{SW} .

↗ For online configuration on flender.com, click on the item no.

FASTEX EC220

self-centering without axial hub displacement,
with inner diameters from 300 to 500 mm

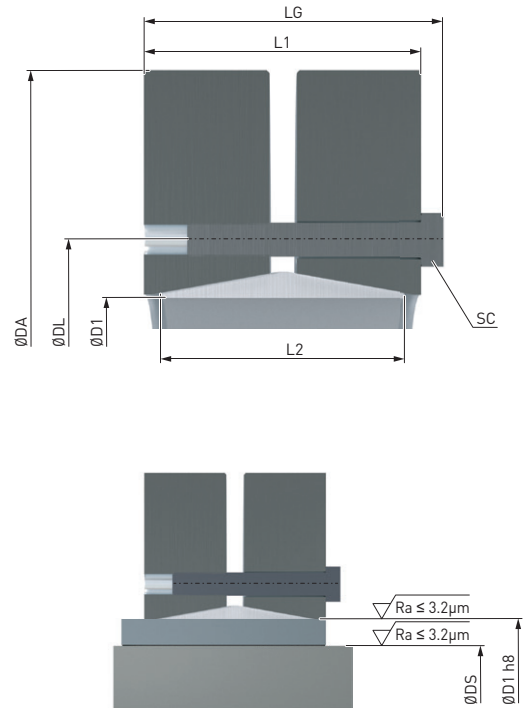
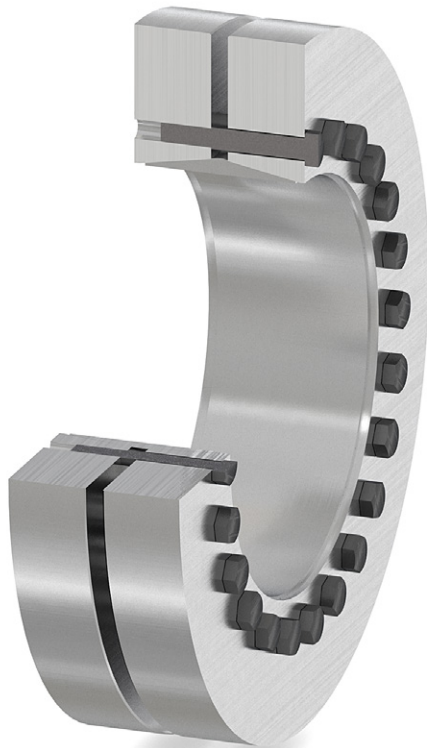

Hub exemplary applications

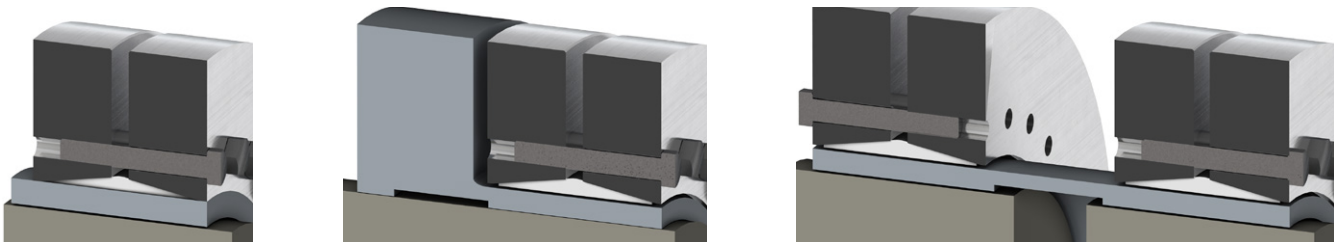

Notes

- Temperature range -20 to 160 °C
- 3-part
- Recommended shaft tolerances j6 (DS 10 - 30 mm), h6 (DS 31 - 50 mm), g6 (DS 51 - 500 mm) with a surface quality of $Ra \leq 3.2 \mu m$
- Recommended bore tolerance H6 (DS 10 - 80 mm), H7 (DS 81 - 500 mm) with a surface quality of $Ra \leq 3.2 \mu m$

Ordering example

- FASTEX EC220 external clamping set, size 350 x 580

Article no.: FFA:F2E01152136

Size D1 × D2 mm	Dimensions					Screw DIN EN ISO 4014 – 10.9				Surface pressure P_{SH} N/mm ²	Weight <i>m</i> kg	➤ Article no. ²⁾
	DS mm	LG mm	L1 mm	L2 mm	DL mm	SC	T_A ¹⁾ Nm	T_{CL} Nm	F_a kN			
300 × 485	230	154.5	142	122	364	M20	490	274 000	2 430	208	118	FFA:F2E01152132
	240							296 000	2 560			
	245							316 000	2 630			
320 × 520	240	154.5	142	122	386	M20	490	311 000	2 640	217	131	FFA:F2E01152133
	250							340 000	2 780			
	260							375 000	2 900			
330 × 520	250	154.5	142	122	386	M20	490	352 000	2 800	231	126	FFA:F2E01152134
	260							385 000	2 900			
	270							420 000	3 100			
340 × 570	250	168.5	156	134	408	M20	490	389 000	3 115	223	186	FFA:F2E01152135
	260							422 000	3 245			
	270							459 000	3 400			
350 × 580	270	174.5	162	140	432	M20	490	443 000	3 275	208	195	FFA:F2E01152136
	280							480 000	3 430			
	285							500 000	3 500			
360 × 590	280	174.5	162	140	432	M20	490	462 000	3 300	202	204	FFA:F2E01152137
	290							500 000	3 460			
	300							530 000	3 600			
380 × 645	290	183	168	144	458	M24	840	570 000	3 900	222	239	FFA:F2E01152138
	300							610 000	4 070			
	310							660 000	4 260			
390 × 660	300	183	168	144	468	M24	840	625 000	4 170	227	260	FFA:F2E01152139
	310							670 000	4 325			
	320							720 000	4 500			
400 × 680	315	183	168	144	480	M24	840	671 000	4 270	221	280	FFA:F2E01152140
	320							695 000	4 340			
	330							745 000	4 500			
420 × 690	330	203	188	164	504	M24	840	782 000	4 460	212	316	FFA:F2E01152141
	340							841 000	5 000			
	350							902 000	5 200			
440 × 750	340	217	202	177	527	M24	840	805 000	4 760	187	408	FFA:F2E01152142
	350							861 000	4 930			
	360							920 000	5 120			
460 × 770	360	217	202	177	547	M24	840	1 000 000	5 560	210	420	FFA:F2E01152143
	370							1 073 000	5 820			
	380							1 141 000	6 020			
470 × 800	380	228	213	188	570	M24	840	1 214 000	6 368	207	515	FFA:F2E01152144
	390							1 285 000	6 590			
	400							1 365 000	6 825			
480 × 800	380	228	213	188	570	M24	840	1 175 000	6 200	203	505	FFA:F2E01152145
	390							1 250 000	6 450			
	400							1 312 000	6 580			
500 × 850	400	230	213	188	590	M27	1250	1 314 000	6 570	207	575	FFA:F2E01152146
	410							1 382 000	6 740			
	420							1 460 000	7 000			

¹⁾ The specified tightening torques T_A are the maximum values. The tightening torque can be reduced by max. 40% to proportionally reduce the transmissible torque T_{CL} , the transmissible axial force F_a and the surface pressures P_{SN} and P_{SW} .

➤ For online configuration on flender.com, click on the item no.

APPENDIX

Related catalogs	A/2
Our coupling groups at a glance	A/4
Individual solutions	A/6
Flender Services	A/10

RELATED CATALOGS

A

Torsionally Rigid Couplings

FLE 10.1
FLEX-C10001-00-7600



Flexible Couplings

FLE 10.2
FLEX-C10002-00-7600



Highly Flexible Couplings

FLE 10.3
FLEX-C10003-00-7600



Fluid Couplings

FLE 10.4
FLEX-C10004-00-7600



ARPEX

High Performance Couplings
FLE 10.5
FLEX-C10120-00-7600



SIPEX und BIPEX-S

Backlash-free couplings
FLE 10.6
FLEX-C10121-00-7600



ARPEX

Safety couplings
FLE 10.7
FLEX-C10122-00-7600



FASTEX

Clamping elements
FLE 10.8
FLEX-C10152-00-7600



FLENDER SIP

Standard Industrial Planetary Gear Units

MD 31.1

PDMD-C10154-00

**FLENDER CHG**

Helical Gear Units

MD 20.10

PDMD-C10155-00

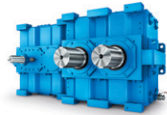
**Gear units**

Fast Track

MD 20.12

PDMD-C10156-00

**Bucket Elevator Drives**

MD 20.2

PDMD-C10157-00

**PLANUREX 3**

Planetary Gear Units

FLE 20.3

FLEX-C10052-00-7600

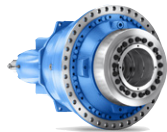
**Paper Machine Drives**

MD 20.5

PDMD-C10159-00

**Conveyor Belt Drives**

MD 20.6

PDMD-C10160-00

**Marine Reduction Gearboxes**

MD 20.7

PDMD-C10161-00

**DUORED 2**

Helical Gear Units, Load-sharing

MD 20.8

PDMD-C10162-00

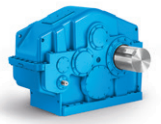
**Pinion Drive for Tube Mills**

MD 20.9

PDMD-C10163-00



OUR COUPLING GROUPS AT A GLANCE

A

N-EUPEX, RUPEX and N-BIPEX

Flexible Couplings

Flexible Flender couplings have a wide range of possible applications. A broad standard modular system as well as specially designed application-specific couplings are available.

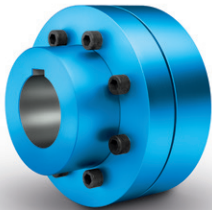

N-EUPEX
cam couplings
Rated torque:
19 Nm ... 85,000 Nm

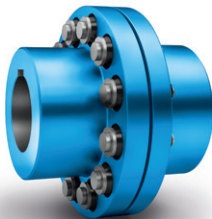

RUPEX
pin-and-bush couplings
Rated torque:
200 Nm ... 1,690,000 Nm



N-BIPEX
cam couplings
Rated torque:
12 Nm ... 4,650 Nm

ELPEX, ELPEX-B and ELPEX-S

Highly Flexible Couplings

ELPEX® couplings are free of circumferential back-lash. Their damping capacity and low torsional stiff-ness make them especially well-suited for coupling machines with strongly non-uniform torque characteristics or large shaft misalignment.



ELPEX
elastic ring couplings
Rated torque:
1,600 Nm ... 90,000 Nm



ELPEX-B
elastic tire couplings
Rated torque:
24 Nm ... 14,500 Nm



ELPEX-S
rubber disk couplings
Rated torque:
330 Nm ... 63,000 Nm

ZAPEX gear couplings and ARPEX all-steel couplings

Torsionally rigid couplings

For transmission of high torques, we offer both ARPEX all-steel couplings and ZAPEX gear couplings in a range of versions. Their purposes of application vary according to specific requirements with respect to shaft misalignment, temperature and torque.

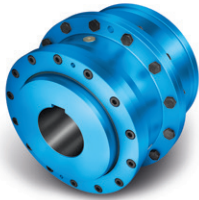

ZAPEX
gear couplings
Rated torque:
1,300 Nm ... 7,200,000 Nm



ARPEX
high Performance Couplings
Rated torque:
1,000 Nm ... 588,500 Nm



N-ARPEX and ARPEX
all-steel couplings
Rated torque:
92 Nm ... 2,000,000 Nm

BIPEX-S and SIPEX

Backlash-free couplings

The vibration-damping, electrically insulating plug-in BIPEX-S elastomer couplings and SIPEX metal bellows couplings with very high torsional stiffness deliver especially isogonal torque transmission.

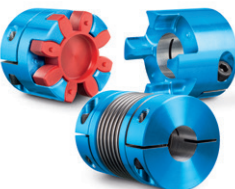

BIPEX-S and SIPEX
Rated torque:
0.1 Nm ... 5,000 Nm

FLUDEX

Hydrodynamic couplings

The FLUDEX hydrodynamic fluid coupling works according to the Föttinger principle. It functions entirely free of wear.



FLUDEX
fluid Couplings
Power:
1.2 kW ... 2,500 kW

Application-specific couplings

Couplings for rail vehicles must meet high demands. Due to their high degree of standardization and wide variety, they can be used in the most diverse vehicle types.

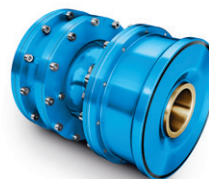

Railway coupling
Rated torque:
1,000 Nm ... 9,500 Nm

Each wind turbine coupling is designed to optimally meet the requirements of the respective wind turbine. The coupling connects the fast-running gear shaft with the generator shaft and is available for wind turbines with a capacity of up to 12 MW.

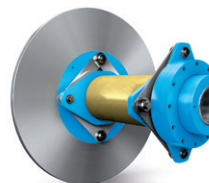

Wind turbine couplings
Rated torque:
10,000 Nm ... 60,000 Nm

Flender's system competence turns first-class components into systems with tangible added value. Drive systems from Flender ensure maximum productivity, energy efficiency and reliability in any automation environment.

Consultation

Our customers use our interdisciplinary know-how, our application competence, our innovation strength and, last but not least, our experience to find the right drive system for their individual requirements.

Reduced engineering time, lower costs



Integrated drive portfolio

We not only provide gear units and couplings, but also have the competence in electrical drive technology that enables us to offer the entire drive train – perfectly integrated, with optimal interaction between all components, as a standard or individual solution.

Fewer interface risks, more efficiency

INDIVIDUAL SOLUTIONS.

We have the right solution for you, even if your requirements are special. We no longer have to newly develop every special solution. Many solutions are already available.

At [flender.com](https://www.flender.com), we provide application-specific solutions for your special requirements.

Use our online configurator, which allows you to create tailored product combinations.

Flender service

From diagnostics and support, replacement part and repair services, all the way to maintenance and retrofit services – the Flender service portfolio creates individual solutions, fully and completely tailored to the needs of our customers. In this way, a gear unit remains an original Flender gear unit.

Increased system availability, reduced lifecycle costs

DIAGNOSTEX

Ensuring the process stability requires status-oriented maintenance of the drive train. With DIAGNOSTEX®, sensors measure deviations of our gear units from the target status. These can be analyzed and evaluated in terms of maximized system availability.

Industrie 4.0, reduced costs

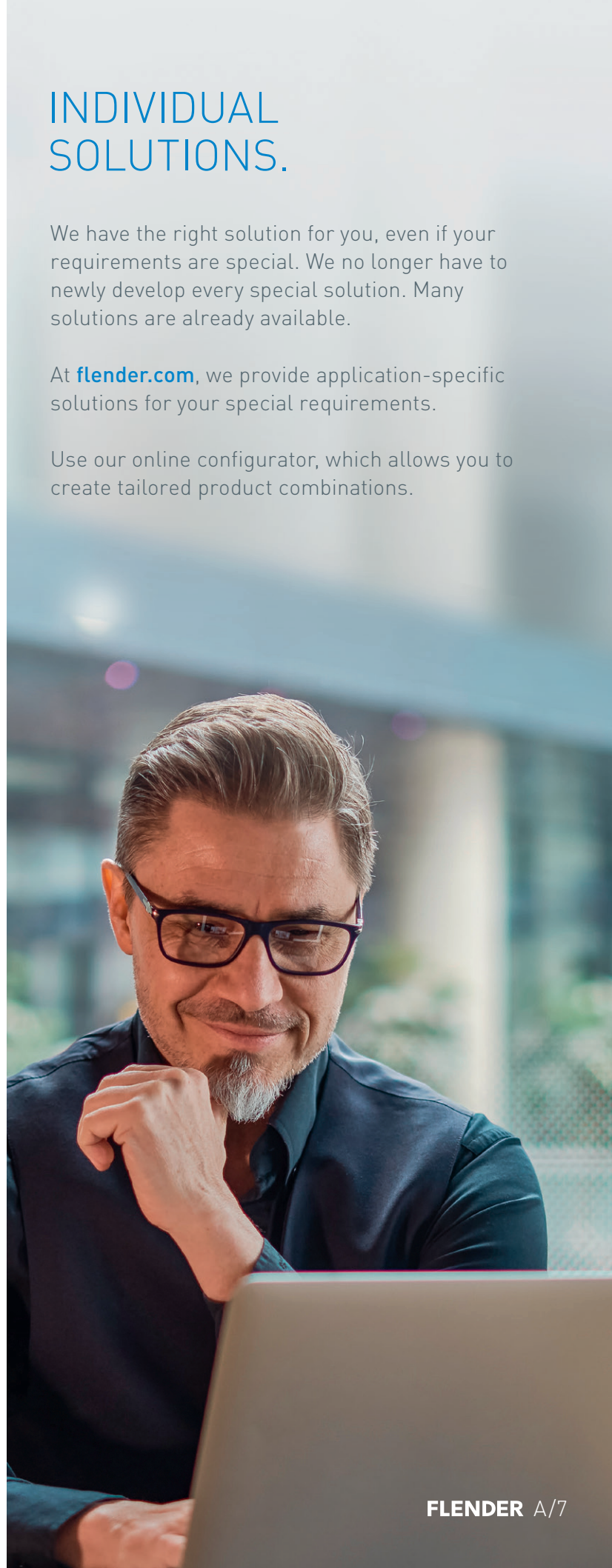

GREAT EXPERTISE IN YOUR INDUSTRY TOO.

Each industry has its own conditions. Every application has its own specific requirements. We are looking forward to meeting your challenges.

We probably already have the right solution at hand. Here are a few examples:



Minerals and mining

Requirement:
Perfectly coordinated drive system



Cement

Requirement:
Low maintenance effort and cost,
sealing due to dirt in surroundings



Plastics and rubber

Requirement:
Absorption of high axial forces,
suitability for explosion protection

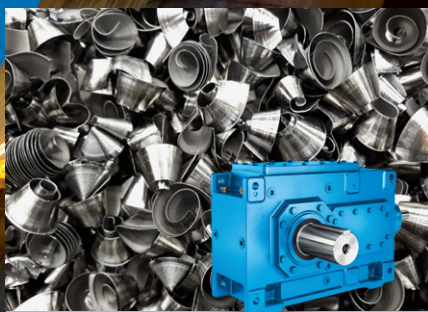

Environmental and recycling

Requirement:
Highest possible reliability, rugged
design



Pulp and paper

Requirement:
Suitability for centrally located
lubrication



Industrial cranes

Requirement:
Quick availability, version with
double drive shaft



Chemicals

Requirement:
Absorption of forces from the manufacturing process



Power generation

Requirement:
Effective cooling, speed adjustment for motor to fan

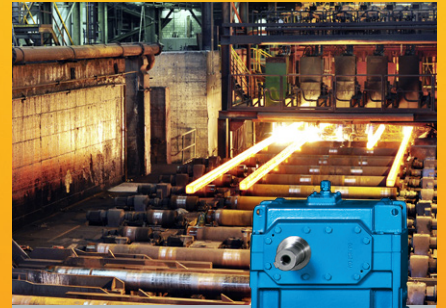

Metals

Requirement:
Harsh working conditions, high peak loads



Harbor cranes

Requirement:
Specific axle clearance, frequent start-up



Oil and gas

Requirement:
Flexible adaptation to speed requirements



Water and wastewater

Requirement:
Absorption of external forces, oil-retaining pipe required



AN ORIGINAL FOR THE LONG TERM WITH ORIGINAL FLENDER SERVICES

Ever increasing requirements make it more and more important for industrial plants to work with maximum productivity and efficiency. Flender Services give companies a decisive advantage over the competition in industry, the acquisition of raw materials and energy production. In view of the high cost pressure, increasing energy prices and stricter and stricter environmental stipulations, our services are becoming a decisive factor to success over the competition.

Enjoy the support of our service experts, from planning, development and operation to the modernization of your plant and benefit from our experience and in-depth know-how of your application – in more than 100 countries, seven days a week, 24 hours a day.

Reduce standstills, minimize downtimes due to failure, and increase the productivity, flexibility and cost efficiency of your plant.

OUR OFFER FOR GEAR UNITS AND COUPLINGS AT A GLANCE.

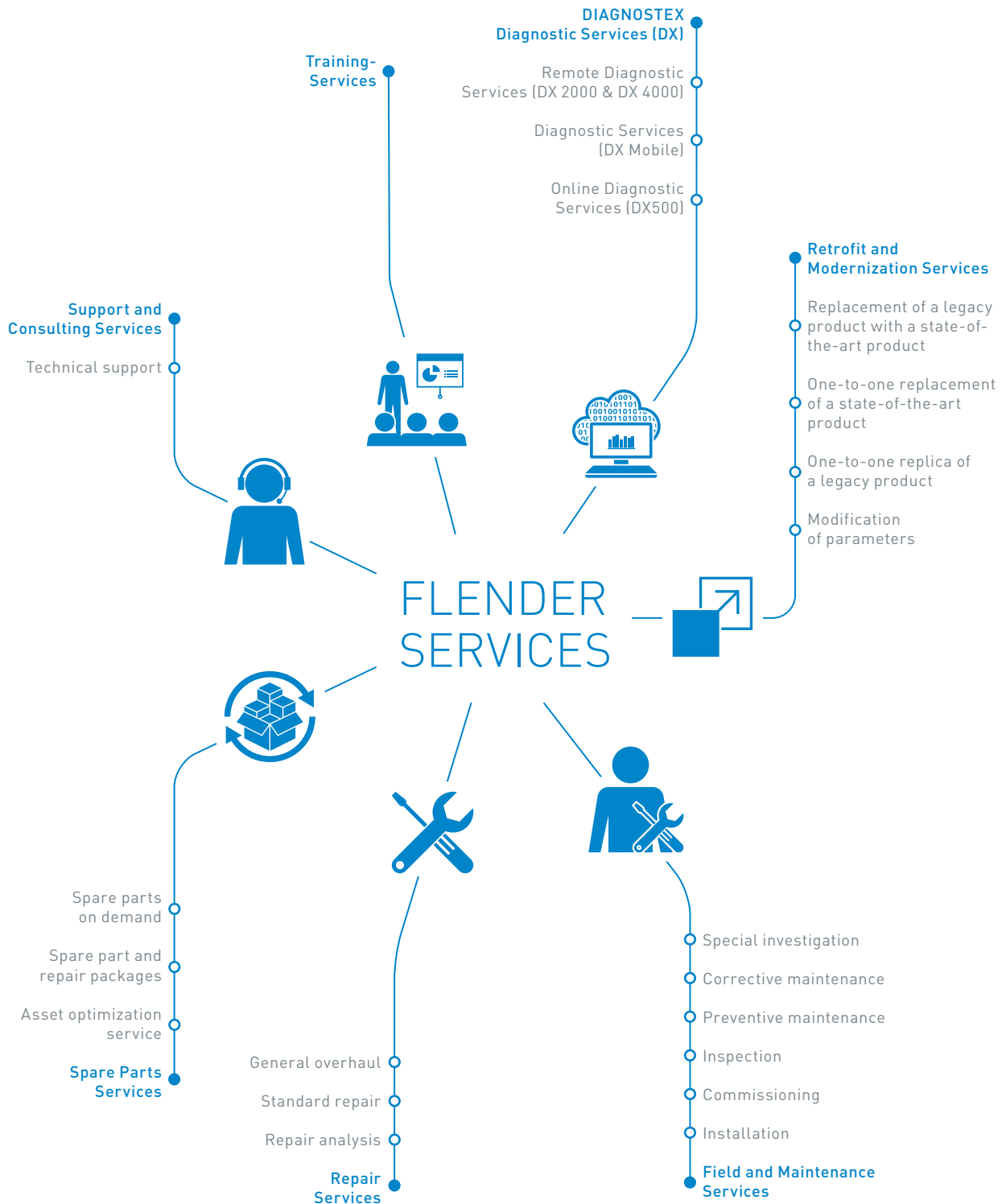

FLENDER CLAMPING ELEMENTS CATALOG **FLE 10.8** EDITION 2023 EN



WE
MOVE_{the}
WORLD

Flender GmbH
Alfred-Flender-Straße 77
46395 Bocholt
Germany

Article no.: FLEX-C10152-00-7600

Subject to changes and errors.

The information given in this product catalog includes descriptions and performance features that in specific applications do not always apply in the form described or may change through further-development of the products. The desired performance features are binding only if they are expressly agreed on conclusion of contract. Subject to availability for delivery and to technical changes.