

FLENDER COUPLINGS  
CATALOG **FLE 10**  
EDITION 2023 EN



## STANDARD COUPLINGS



# STANDARD COUPLINGS



Catalog FLE 10 Edition 2023 EN

## Introduction

### Torsionally Rigid Gear Couplings

ZAPEX ZW

ZAPEX ZN

### Torsionally Rigid All-Steel Couplings

N-ARPEX, ARPEX

### Flexible Couplings

N-EUPEX

RUPEX

N-BIPEX

### Highly Flexible Couplings

ELPEX-B

ELPEX-S

ELPEX

### Fluid Couplings

FLUDEX

### Backlash-free Couplings

SIPEX

BIPEX-S

## Appendix

E

4

5

6

7

8

9

10

11

12

13

14

15

A

# FLE 10 CATALOG GROUP



Product catalog FLE 10.1  
FLEX-C10001-00-7600  
**Torsionally Rigid Couplings**



Product catalog FLE 10.3  
FLEX-C10003-00-7600  
**Highly Flexible Couplings**



Product catalog FLE 10.2  
FLEX-C10001-00-7600  
**Flexible Couplings**



Product catalog FLE 10.4  
FLEX-C10004-00-7600  
**Fluid Couplings**

For further coupling catalogs, see page A/6

FLENDER COUPLINGS  
CATALOG **FLE 10.5**  
EDITION EN



HIGH PERFORMANCE COUPLINGS  
ARPEX

[flender.com](http://flender.com)

**FLENDER**

Product catalog FLE 10.5  
FLEX-C10120-00-7600  
**High Performance Couplings**

FLENDER-COUPLINGS  
CATALOG **FLE 10.7**  
EDITION EN



SAFETY COUPLINGS  
ARPEX

[flender.com](http://flender.com)

**FLENDER**

Product catalog FLE 10.7  
FLEX-C10122-00-7600  
**Safety couplings**

FLENDER COUPLINGS  
CATALOG **FLE 10.6**  
EDITION EN



BACKLASH-FREE COUPLINGS  
SIPEX AND BIPEX-S

[flender.com](http://flender.com)

**FLENDER**

Product catalog FLE 10.6  
FLEX-C10121-00-7600  
**Backlash-free couplings**

FLENDER CLAMPING ELEMENTS  
CATALOG **FLE 10.8**  
EDITION EN



CLAMPING ELEMENTS  
FASTEX

[flender.com](http://flender.com)

**FLENDER**

Product catalog FLE 10.8  
FLEX-C10152-00  
**Clamping elements**

# INTRODUCTION

E

The mechanical drive train comprises individual units such as motor, gear unit and driven machine. The coupling connects these component assemblies.

As well as the transmission of rotary motion and torque, other requirements may be made of the coupling.

- Compensation for shaft misalignment with low restorative forces
- Control of characteristic angular vibration frequency and damping
- Interruption or limitation of torque
- Noise insulation, electrical insulation

Couplings are frequently chosen after the machines to be connected have already been selected. Thanks to a large number of different coupling assembly options, specified marginal conditions for clearance and connection geometry can be met from the standard range. The coupling also performs secondary functions, e.g. providing a brake disk or brake drum for operating or blocking brakes, devices to record speed or the attachment of sprockets or pulleys.

Couplings are divided into two main groups, couplings and clutches.

Clutches interrupt or limited the transmissible torque. The engaging and disengaging forces on externally operated clutches are introduced via a mechanically, electrically, hydraulically or pneumatically operating mechanism. Overload, centrifugal or freewheel clutches draw their engaging energy from the transmitted output.

Rigid couplings, designed as clamp, flanged or mechanism couplings, connect machines which must not undergo any shaft misalignment. Hydrodynamic couplings, often also called fluid or Föttinger couplings, are used as starting couplings in drives with high mass moments of inertia of the driven machine. In drive technology very often flexible, positive couplings, which may be designed to be torsionally rigid, torsionally flexible or highly flexible, are used.

Torsionally rigid couplings are designed to be rigid in a peripheral direction and flexible in radial and axial directions. The angle of rotation and torque are conducted through the coupling without a phase shift.

Torsionally flexible couplings have resilient elements usually manufactured from elastomer materials. Using an elastomer material with a suitable ShoreA hardness provides the most advantageous torsional stiffness and damping for the application. Shaft misalignment causes the resilient elements to deform.

Highly flexible couplings have large-volume (elastomer) resilient elements of low stiffness. The angle of rotation and torque are conducted through the coupling with a considerable phase shift.

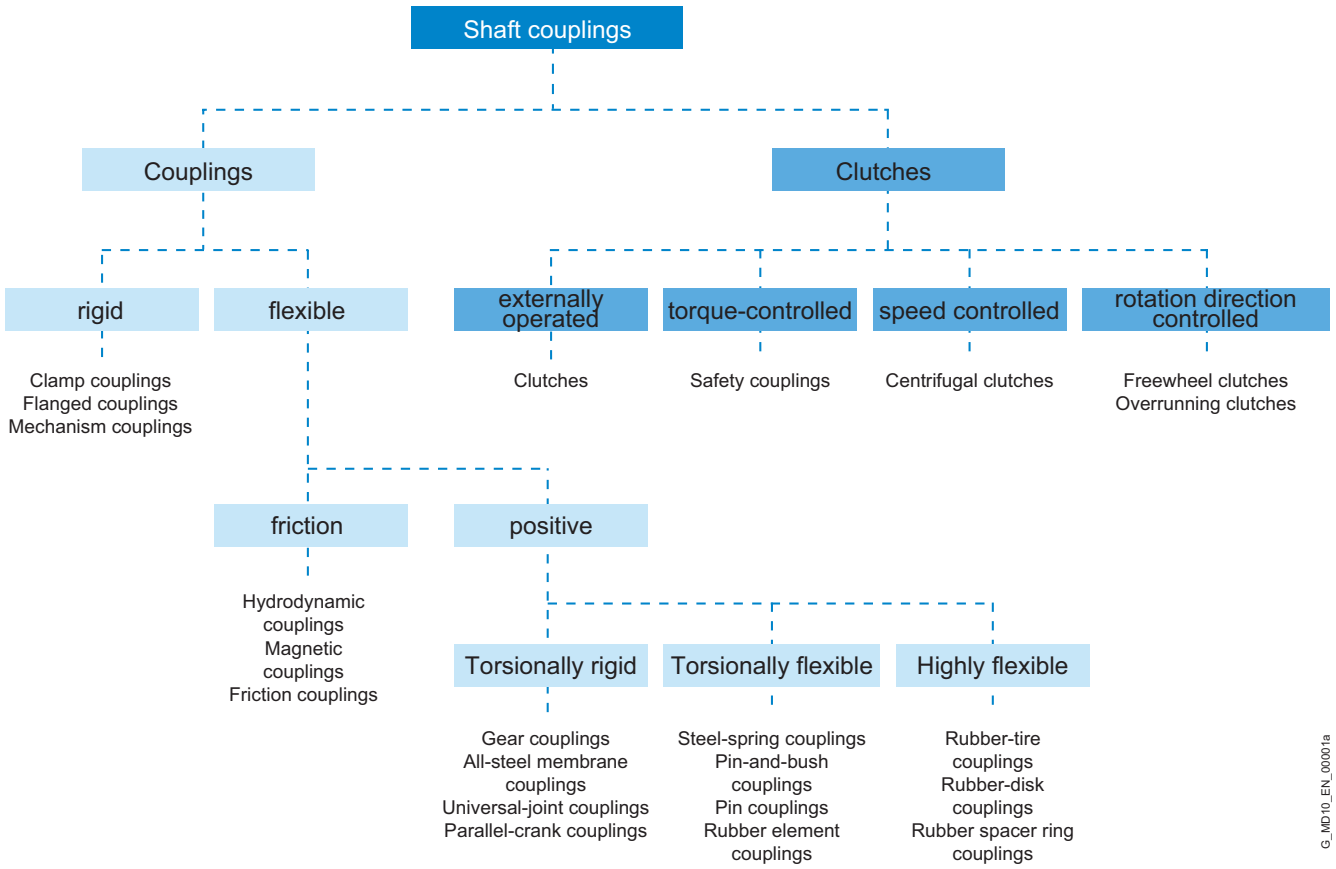

G\_MD10\_EN\_00001a

# OUR COUPLING GROUPS AT A GLANCE

E

N-EUPEX, RUPEX and N-BIPEX

## Flexible Couplings

Flexible Flender couplings have a wide range of possible applications. A broad standard modular system as well as specially designed application-specific couplings are available.

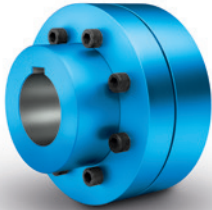

**N-EUPEX**  
cam couplings  
Rated torque:  
19 Nm ... 85,000 Nm

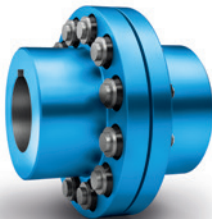

**RUPEX**  
pin-and-bush couplings  
Rated torque:  
200 Nm ... 1,690,000 Nm



**N-BIPEX**  
cam couplings  
Rated torque:  
12 Nm ... 4,650 Nm

ELPEX, ELPEX-B and ELPEX-S

## Highly Flexible Couplings

ELPEX® couplings are free of circumferential back-lash. Their damping capacity and low torsional stiffness make them especially well-suited for coupling machines with strongly non-uniform torque characteristics or large shaft misalignment.



**ELPEX**  
elastic ring couplings  
Rated torque:  
1,600 Nm ... 90,000 Nm



**ELPEX-B**  
elastic tire couplings  
Rated torque:  
24 Nm ... 14,500 Nm



**ELPEX-S**  
rubber disk couplings  
Rated torque:  
330 Nm ... 63,000 Nm



ZAPEX gear couplings and ARPEX all-steel couplings

### Torsionally rigid couplings

For transmission of high torques, we offer both ARPEX all-steel couplings and ZAPEX gear couplings in a range of versions. Their purposes of application vary according to specific requirements with respect to shaft misalignment, temperature and torque.

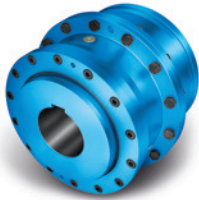

**ZAPEX**  
gear couplings  
Rated torque:  
1,300 Nm ... 7,200,000 Nm



**ARPEX**  
high Performance Couplings  
Rated torque:  
1,000 Nm ... 588,500 Nm



**N-ARPEX and ARPEX**  
all-steel couplings  
Rated torque:  
92 Nm ... 2,000,000 Nm

BIPEX-S and SIPEX

### Backlash-free couplings

The vibration-damping, electrically insulating plug-in BIPEX-S elastomer couplings and SIPEX metal bellows couplings with very high torsional stiffness deliver especially isogonal torque transmission.



**BIPEX-S and SIPEX**  
Rated torque:  
0.1 Nm ... 5,000 Nm

FLUDEX

### Hydrodynamic couplings

The FLUDEX hydrodynamic fluid coupling works according to the Föttinger principle. It functions entirely free of wear.



**FLUDEX**  
fluid Couplings  
Power:  
1.2 kW ... 2,500 kW

### Application-specific couplings

Couplings for rail vehicles must meet high demands. Due to their high degree of standardization and wide variety, they can be used in the most diverse vehicle types.

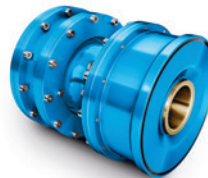

**Railway coupling**  
Rated torque:  
1,000 Nm ... 9,500 Nm

Each wind turbine coupling is designed to optimally meet the requirements of the respective wind turbine. The coupling connects the fast-running gear shaft with the generator shaft and is available for wind turbines with a capacity of up to 12 MW.

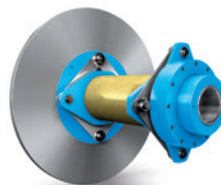

**Wind turbine couplings**  
Rated torque:  
10,000 Nm ... 60,000 Nm



# TECHNICAL INFORMATION AND COUPLING SELECTION

<b>Technical Information</b>	<b>E/10</b>
Shaft misalignment	E/10
Balancing	E/11
Shaft-hub connections	E/13
Standards	E/14
Key to symbols	E/15
<hr/>	
<b>Selection of the coupling series</b>	<b>E/16</b>
Typical coupling solutions for different example applications	E/17
<hr/>	
<b>Selection of the coupling size</b>	<b>E/18</b>
Coupling load in continuous operation	E/18
Coupling load at maximum and overload conditions	E/19
Coupling load due to dynamic torque load	E/19
Checking the maximum speed	E/20
Checking permitted shaft misalignment	E/20
Checking bore diameter, mounting geometry and coupling design	E/20
Coupling behavior under overload conditions	E/20
Checking shaft-hub connection	E/20
Checking low temperature and chemically aggressive environment	E/20
<hr/>	
<b>Features of the standard type</b>	<b>E/21</b>
<hr/>	

# TECHNICAL INFORMATION

E

## Shaft misalignment

Shaft misalignment is the result of displacement during assembly and operation and, where machines constructed with two radial bearings each are rigidly coupled, will cause high loads being placed on the bearings. Elastic deformation of base frame, foundation and machine housing will lead to shaft misalignment which cannot be prevented, even by precise alignment.

Furthermore, because individual components of the drive train heat up differently during operation, heat expansion of the machine housings causes shaft misalignment. Poorly aligned drives are often the cause of seal, rolling bearing or coupling failure. Alignment should be carried out by specialist personnel in accordance with operating instructions.

Depending on the direction of the effective shaft misalignment a distinction is made between:

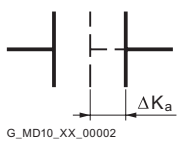

Axial misalignment

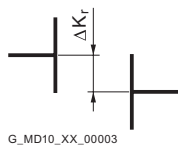

Radial misalignment

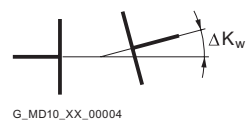

Angular misalignment

Couplings can be categorized into one of the following groups:

### Single-joint couplings

Couplings with flexible elements mainly made of elastomer materials. Shaft misalignment results in deformation of the elastomer elements. The elastomer elements can absorb shaft misalignment as deformations in an axial, radial and angular direction. The degree of permissible misalignment depends on the coupling size, the speed and the type of elastomer element. Single-joint couplings do not require an adapter and are therefore short versions.

**Example:**

In the case of a RUPLEX RWN 198 coupling with an outer diameter of 198 mm and a speed of 1500 rpm, the permitted radial misalignment is  $\Delta K_r = 0.3 \text{ mm}$ .

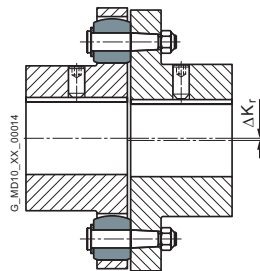

### Two-joint couplings

Two-joint couplings are always designed with an adapter. The two joint levels are able to absorb axial and angular misalignment. Radial misalignment occurs via the gap between the two joint levels and the angular displacement of the joint levels. The permitted angular misalignment per joint level is frequently about 0.5°. The permitted shaft misalignment of the coupling can be adjusted via the length of the adapter. If there are more than two joint levels, it is not possible to define the position of the coupling parts relative to the axis of rotation. (The less frequently used parallel-crank couplings are an exception).

**Example:**

N-ARPEX ARN-6 NEN 217-6 with a shaft distance of 140 mm with a permitted radial misalignment of  $\Delta K_r = 2.2 \text{ mm}$  [angle per joint level 1.0°].

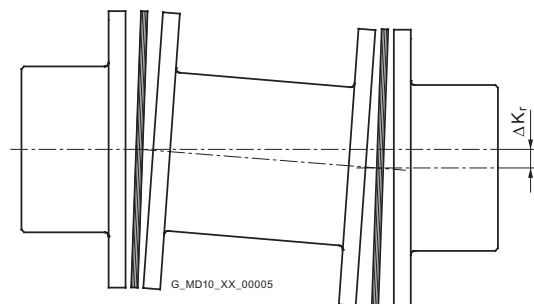

## Balancing

### Balance quality levels

The so-called quality level G to DIN ISO 21940 indicates a range of permitted residual imbalance from zero up to an upper limit. Applications can be grouped on the basis of similarity analysis. For many applications a coupling balance quality of G 16 is sufficient. On drives susceptible to vibration the balance quality should be G 6.3. Only in special cases is a better balance quality required.

### Balancing standard in accordance with DIN ISO 21940-32

Besides the required balance quality, it is necessary to set standards which define how the mass of the parallel key is to be taken into consideration when balancing. In the past, motor rotors have frequently been balanced in accordance with the full parallel key standard. The "appropriate" balance condition of the coupling hub was described as "balancing with open keyway" or "balancing after keyseating". Today it is usual for the motor rotor, as well as the gear unit and driven machine shaft, to be balanced in accordance with the half parallel key standard.

### Full parallel key standard

The parallel key is inserted in the shaft keyway, then balancing is carried out. The coupling hub must be balanced without parallel key after keyseating.

Marking of shaft and hub with "F" (for "full").

### Half parallel key standard

The balancing standard normally applied today. Before balancing, a half parallel key is inserted in the shaft and another in the coupling hub. Alternatively, balancing can be carried out before cutting the keyway.

The balanced parts must be marked with an "H". This marking can be dispensed with if it is absolutely clear which parallel key standard has been applied.

### No parallel key standard

Balancing of shaft and coupling hub after keyseating, but without parallel key. Not used in practice. Marking of shaft and hub with "N" (for "no").  
The length of the parallel key is determined by the shaft keyway. Coupling hubs may be designed considerably shorter than the shaft.

To prevent imbalance forces caused by projecting parallel key factors when balancing in accordance with the half parallel key standard in the case of applications with high balancing quality requirements, grooved spacer rings can be fitted or stepped parallel keys used.

### Flender Balancing Standard

The balancing quality level, together with the operating speed, results in the maximum permissible eccentricity of the center of gravity of the coupling or the coupling subassembly. In the Flender article number the balancing quality can be preset with the help of the order code. Additionally, also the balance quality level to DIN ISO 21940 can be preset together with the operating speed belonging to it, which then be taken as priority.

$$e_{perm} = 9550 \cdot \frac{G}{n}$$

$$e_{coupl} \leq e_{perm}$$

Permitted eccentricity of center of gravity  $e_{perm}$  in  $\mu\text{m}$   
 Eccentricity of center of gravity of coupling  $e_{coupl}$  in  $\mu\text{m}$   
 Balancing quality level G in mm/s  
 Coupling speed n in rpm

Eccentricity of center of gravity of coupling $e_{coupl}$	Flender balancing quality	Order code
maximum 100 $\mu\text{m}$	standard balancing	without specification
maximum 40 $\mu\text{m}$	fine balancing	W02
maximum 16 $\mu\text{m}$	micro-balancing	W03
better than 16 $\mu\text{m}$	special balancing	on request

# TECHNICAL INFORMATION

E

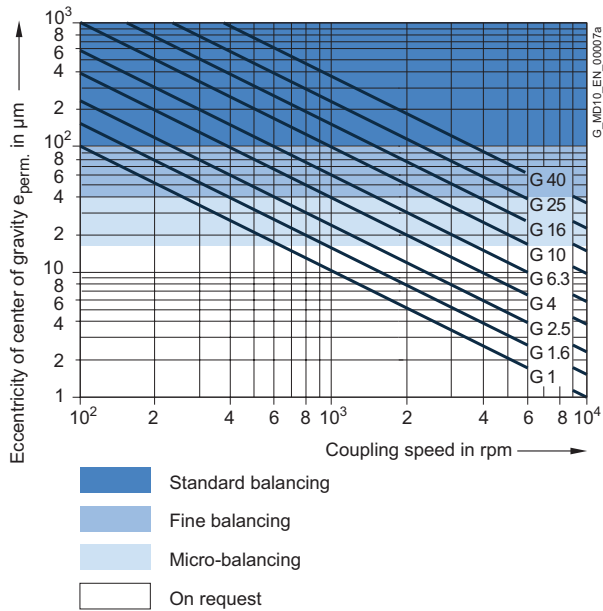

Example:  
Coupling speed = 1450 rpm  
required balancing quality level G 6.3

$$e_{perm} = 9550 \cdot \frac{G}{n} = 9550 \cdot \frac{6.3}{1450} \mu\text{m}$$

Thus, the required eccentricity of center of gravity is 41.5 µm. The fine balancing with a maximum eccentricity of center of gravity of 40 mm fulfills this requirement; therefore, the order code W02 has to be specified when ordering.

For many applications the following balancing quality recommendation applies:

Coupling	standard balancing $v = DA \cdot n/19100$	fine balancing
short version with $LG \leq 3 \times DA$	$v < 30 \text{ m/s}$	$v > 30 \text{ m/s}$
long version with $LG > 3 \times DA$	$v \leq 15 \text{ m/s}$	$v > 15 \text{ m/s}$

Peripheral speed	$v$	in mm/s
Coupling outer diameter	DA	in mm
Coupling speed	$n$	in rpm
Coupling length	LG	in mm

The following standards on balancing must be observed:

- couplings are balanced in subassemblies.
- hub parts without finished bore are unbalanced.
- the number of balancing levels (one- or two-level balancing) is specified by Flender.
- without special specification balancing is done in accordance with the half-parallel-key standard. Balancing in accordance with the full-parallel-key standard must be specified in the order number.
- For FLUDEX couplings special balancing standards specified in Section 13 apply.
- ARPEX couplings in standard balancing quality are unbalanced. Thanks to steel components machined all over and precisely guided adapters the balancing quality of standard balancing is nearly always adhered to.

## Shaft-hub connections

The bore and the shaft-hub connection of the coupling are determined by the design of the machine shaft. In the case of IEC standard motors, the shaft diameters and parallel key connections are specified in accordance with DIN EN 50347. For diesel motors, the flywheel connections are frequently specified in accordance with SAE J620d or DIN 6288. Besides the very widely used connection of shaft and hub with parallel keys to DIN 6885 and cylindrically bored hubs, couplings with Taper clamping bushes, clamping sets, shrink-fit connections and splines to DIN 5480 are common.

The form stability of the shaft/hub connection can only be demonstrated when shaft dimensions and details of the connection are available. The coupling torques specified in the tables of power ratings of the coupling series do not apply to the shaft-hub connection unrestrictedly.

In the case of the shaft-hub connection with parallel key, the coupling hub must be axially secured, e.g. with a set screw or end washer. The parallel key must be secured against axial displacement in the machine shaft.

All Flender couplings with a finished bore and parallel keyway are designed with a set screw. Exceptions are some couplings of the FLUDEX series, in which end washers are used. During assembly, Taper clamping bushes are frictionally connected to the machine shaft.

# TECHNICAL INFORMATION

E

## Standards

### Machines

2006/42/EG	EC Machinery Directive
2014/34/EU	ATEX Directive – Manufacturer
1999/92/EG	ATEX Directive – Operator – and ATEX Guideline to Directive 1999/92/EC
DIN EN 80079-36	Non-electrical equipment for use in potentially explosive atmospheres
DIN EN 1127	Explosive atmospheres, explosion prevention and protection
DIN EN 50347	General-purpose three-phase induction motors having standard dimensions and outputs

### Couplings

DIN 740	Flexible shaft couplings Part 1 and Part 2
VDI Guideline 2240	Shaft couplings - Systematic subdivision according to their properties VDI Technical Group Engineering Design 1971
API 610	Centrifugal Pumps for Petroleum, Chemical and Gas Industry Services
API 671	Special Purpose Couplings for Petroleum, Chemical and Gas Industry Services
ISO 10441	Petroleum, petrochemical and natural gas industries – Flexible couplings for mechanical power transmission-special-purpose applications
ISO 13709	Centrifugal pumps for petroleum, petrochemical and natural gas industries

### Balancing

DIN ISO 21940	Requirements for the balancing quality of rigid rotors
DIN ISO 21940-32	Mechanical vibrations; standard governing the type of parallel key during balancing of shafts and composite parts

### Shaft-hub connections

DIN 6885	Driver connections without taper action – parallel keys – keyways
SAE J620d	Flywheels for industrial engines ...
DIN 6288	Reciprocating internal combustion engines Dimensions and requirements for flywheels and flexible couplings
ASME B17.1	Keys and keyseats
DIN EN 50347	General-purpose three-phase induction motors with standard dimensions and output data
BS 46-1:1958	Keys and keyways and taper pins Specification



## Key to symbols

Name	Symbols	Unit	Explanation
Torsional stiffness, dynamic	$C_{Tdyn}$	Nm/rad	For calculating torsional vibration
Excitation frequency	$f_{err}$	Hz	Excitation frequency of motor or driven machine
Moment of inertia	$J$	kgm <sup>2</sup>	Moment of inertia of coupling sides 1 and 2
Axial misalignment	$\Delta K_a$	mm	Axial misalignment of the coupling halves
Radial misalignment	$\Delta K_r$	mm	Radial misalignment of the coupling halves
Angular misalignment	$\Delta K_w$	°	Angular misalignment of the coupling halves
Service factor	FB		Factor expressing the real coupling load as a ratio of the nominal coupling load
Frequency factor	FF		Factor expressing the frequency dependence of the fatigue torque load
Temperature factor	FT		Factor taking into account the reduction in strength of flexible rubber materials at a higher temperature
Weight	$m$	kg	Weight of the coupling
Rated speed	$n_N$	rpm	Coupling speed
Maximum coupling speed	$n_{Kmax}$	rpm	Maximum permissible coupling speed
Rated power	$P_N$	kW	Rated output on the coupling, usually the output of the driven machine
Rated torque	$T_N$	Nm	Rated torque as nominal load on the coupling
Fatigue torque	$T_W$	Nm	Amplitude of the dynamic coupling load
Maximum torque	$T_{max}$	Nm	More frequently occurring maximum load, e.g. during starting
Overload torque	$T_{OL}$	Nm	Very infrequently occurring maximum load, e.g. during short circuit or blocking conditions
Rated coupling torque	$T_{KN}$	Nm	Torque which can be transmitted as static torque by the coupling over the period of use.
Maximum coupling torque	$T_{Kmax}$	Nm	Torque which can be frequently transmitted (up to 25 times an hour) as maximum torque by the coupling.
Coupling overload torque	$T_{KOL}$	Nm	Torque which can very infrequently be transmitted as maximum torque by the coupling.
Fatigue coupling torque	$T_{KW}$	Nm	Torque amplitude which can be transmitted by the coupling as dynamic torque at a frequency of 10 Hz over the period of use.
Resonance factor	$V_R$		Factor specifying the torque increase at resonance
Temperature	$T_a$	°C	Ambient temperature of the coupling in operation
Damping coefficient	$\Psi$	psi	Damping parameter

# SELECTION OF THE COUPLING SERIES

E

The coupling series is frequently determined by the driven machine and the design of the drive train. Common selection criteria are listed below and assigned to coupling properties, which are used to select the coupling series. Additionally, the price of the coupling and availability are important criteria for determining the coupling series to be used.

The **FLUDEX series** operates positively and transmits the torque with the aid of a flowing oil or water filling.

FLUDEX couplings are used to reduce starting and/or overload torques. During starting, the motor may, for example, run up within a very short time; because of the FLUDEX coupling, the drive train with the driven machine may accelerate after a delay and without increased torque load.

The FLUDEX coupling cannot compensate for shaft misalignment and is therefore designed in combination with a displacement coupling, a cardan shaft or a belt drive. The displacement coupling may be selected in accordance with the criteria described below.

Selection criteria	Torque range	Speed range	Torsional stiffness		Highly flexible	Operating temperature range
	Rated coupling torque $T_{KN}$	Peripheral speed $v_{max} = DA \cdot n_{max}/19100$	torsionally rigid	torsionally flexible		
ZAPEX	850 ... 7200000 Nm	60 m/s	■	-	-	-20 ... +80 °C
N-ARPEX	350 ... 2000000 Nm	110 m/s	■	-	-	-50 ... +280 °C
ARPEX	92 ... 2000000 Nm	100 m/s	■	-	-	-40 ... +280 °C
N-EUPEX	12 ... 93500 Nm	36 m/s	-	■	-	-50 ... +100 °C
N-EUPEX DS	19 ... 21200 Nm	36 m/s	-	■	-	-30 ... +80 °C
RUPEX	200 ... 1300000 Nm	60 m/s	-	■	-	-50 ... +100 °C
N-BIPEX	12 ... 4650 Nm	45 m/s	-	■	-	-50 ... +100 °C
ELPEX-B	24 ... 14500 Nm	35 m/s	-	-	■	-50 ... +70 °C
ELPEX-S	330 ... 63000 Nm	66 m/s	-	-	■	-40 ... +120 °C
ELPEX	1600 ... 900000 Nm	60 m/s	-	-	■	-40 ... +80 °C

### Typical coupling solutions for different example applications

The specified application factors are recommendations; regulations, rules and practical experience take priority as assessment criteria. No application factor need be taken into account with FLUDEX couplings.

In the case of highly flexible couplings of the ELPEX, ELPEX-S and ELPEX-B series, deviating application factors are stated in the product descriptions. FLUDEX couplings are mostly mounted on the high-speed gear shaft.

Example applications	Application factor FB
<b>Electric motor without gear unit</b>	
Centrifugal pumps	1.0
Piston pumps	1.5
Vacuum pumps	1.5
Fans with $T_N$ less than 75 Nm	1.5
Fans with $T_N$ from 75 to 750 Nm	1.75
Fans with $T_N$ larger than 750 Nm	1.75
Blowers	1.5
Frequency converters / generators	1.25
Reciprocating compressors	1.75
Screw-type compressors	1.5
<b>Internal-combustion engine without gear unit</b>	
Generators	1.75
Pumps	1.5
Fans	1.75
Hydraulic pumps, excavators, construction machines	1.5
Compressors / screw-type compressors	1.5
Agricultural machinery	1.75
<b>Other</b>	
Turbine gear units	1.5
Hydraulic motor - gear unit	1.25
<b>Electric motor with gear unit</b>	
<b>Chemical industry</b>	
Extruders	1.5
Pumps - centrifugal pumps	1.0
Pumps - piston pumps	1.75
Pumps - plunger pumps	1.5
Reciprocating compressors	1.75
Calenders	1.5
Kneaders	1.75
Cooling drums	1.25
Mixers	1.25
Stirrers	1.25
Toasters	1.25
Drying drums	1.25
Centrifuges	1.25
Crushers	1.5
<b>Power generation and conversion</b>	
Compressed air, reciprocating compressors	1.75

Example applications	Application factor FB
Compressed air, screw-type compressors	1.25
Air - Blowers	1.5
Air - Cooling tower fans	1.5
Air - Turbine blowers	1.5
Generators, converters	1.25
Welding generators	1.25
<b>Metal production, iron and steel works</b>	
Plate tilters	1.5
Ingot pushers	1.75
Slabbing mill	1.75
Coiling machines	1.5
Roller straightening machines	1.5
Roller tables	1.75
Shears	1.75
Rollers	1.75
<b>Metal working machines</b>	
Plate bending machines	1.5
Plate straightening machines	1.5
Hammers	1.75
Planing machines	1.75
Presses, forging presses	1.75
Shears	1.5
Grinding machines	1.25
Punches	1.5
Machine tools: Main drives	1.5
Machine tools: Auxiliary drives	1.25
<b>Food industry</b>	
Filling machines	1.25
Kneading machines	1.5
Mashers	1.5
Sugar cane production	1.5
<b>Production machines</b>	
Construction machines, hydraulic pumps	1.25
Construction machines, traversing gears	1.5
Construction machines, suction pumps	1.5
Construction machines, concrete mixers	1.5
Printing machines	1.25
Woodworking - barking drums	1.5
Woodworking - planing machines	1.5

Example applications	Application factor FB
Woodworking - reciprocating saws	1.5
Grinding machines	1.5
Textile machines - winders	1.5
Textile machines - printing machines	1.5
Textile machines - tanning vats	1.5
Textile machines - shredders	1.5
Textile machines - looms	1.5
Packaging machines	1.5
Brick molding machines	1.75
<b>Transport and logistics</b>	
Passenger transport - elevators	1.5
Passenger transport - escalators	1.5
Conveyor systems - bucket elevators	1.5
Conveyor systems - hauling winches	1.5
Conveyor systems - belt conveyors	1.5
Conveyor systems - endless-chain conveyors	1.5
Conveyor systems - circular conveyors	1.5
Conveyor systems - screw conveyors	1.5
Conveyor systems - inclined hoists	1.5
Crane traversing gear	1.5
Hoisting gear	1.5
Crane lifting gear	2.0
Crane traveling gear	1.5
Crane slewing gear	1.5
Crane fly jib hoists	1.5
Cable railways	1.5
Drag lifts	1.5
Winches	1.5
<b>Cellulose and paper</b>	
Paper-making machines, all	1.5
Pulper drives	1.5
<b>Cement industry</b>	
Crushers	1.75
Rotary furnaces	1.5
Hammer mills	1.75
Ball mills	1.75
Pug mills	1.75
Mixers	1.5
Pipe mills	1.5
Beater mills	1.75
Separators	1.5
Roller presses	1.75

# SELECTION OF THE COUPLING SIZE

E

The torque load of the coupling must be determined from the output of the driven machine and the coupling speed.

Rated coupling load  $T_N = 9550 \times P_N / n_N$   
 ( $T_N$  in Nm;  $P_N$  in kW;  $n_N$  in rpm)

The rated coupling load obtained in this way must be multiplied by factors and compared with the rated coupling torque. An ideal but expensive method is to measure the torque characteristic on the coupling. For this, Flender offers special adapters fitted with torque measuring devices.

The rated coupling torque  $T_{KN}$  is the torque which can be transmitted by the coupling over an appropriate period of use if the load is applied to the coupling purely statically at room temperature.

Application factors are to express the deviation of the real coupling load from the "ideal" load condition.

## Coupling load in continuous operation

The operating principles of the driving and driven machines are divided into categories and the application factor FB derived from these in accordance with DIN 3990-1.

**Application factor for N-EUPEX, N-EUPEX-DS, RUPEX, N-BIPEX, ELPEX-B, N-ARPEX, ARPEX, ZAPEX and FLUDEX**

Application factor FB				
Torque characteristic of the driving machine	Torque characteristic of the driven machine			
	uniform	uniform with moderate shock loads	non uniform	very rough
uniform	1.0	1.25	1.5	1.75
uniform with moderate shock loads	1.25	1.5	1.75	2.0
non uniform	1.5	1.75	2.0	2.5

### Examples of torque characteristic of driving machines:

- uniform: Electric motors with soft starting, steam turbines
- uniform with moderate shock loads: Electric motors without soft starting, hydraulic motors, gas and water turbines
- non uniform: Internal-combustion engines

### Examples of torque characteristic in driven machines:

- uniform: Generators, centrifugal pumps for light fluids
- uniform with moderate shock loads: Centrifugal pumps for viscous fluids, elevators, machine tool drives, centrifuges, extruders, blowers, crane drives
- non uniform: Excavators, kneaders, conveyor systems, presses, mills
- very rough: Crushers, excavators, shredders, iron/smelting machinery

Temperature factor FT												
Coupling	Elastomer material	Low temperature °C	Temperature $T_a$ on the coupling									
			under -30 °C	-30 °C up to 50 °C	up to 60 °C	up to 70 °C	up to 80 °C	up to 90 °C	up to 100 °C	up to 110 °C	up to 120 °C	
N-EUPEX	NBR	-30	-	1.0	1.0	1.0	1.0	1.0	-	-	-	-
N-EUPEX	NR	-50	1.1 <sup>1)</sup>	1.0	-	-	-	-	-	-	-	-
N-EUPEX	HNBR	-10	-	1.0	1.0	1.0	1.0	1.0	1.25	1.25	-	-
N-EUPEX	TPU	-50	1.0	1.0	1.05	1.10	1.15	-	-	-	-	-
N-EUPEX DS	NBR	-30	-	1.0	1.0	1.0	1.0	-	-	-	-	-
RUPEX	NBR	-30	-	1.0	1.0	1.0	1.0	-	-	-	-	-
RUPEX	NR	-50	1.1	1.0	-	-	-	-	-	-	-	-
RUPEX	HNBR	-10	-	1.0	1.0	1.0	1.0	1.0	1.25	1.25	-	-
N-BIPEX	TPU	-50	1.0	1.0	1.0	1.0	1.0	1.0	1.0	1.3	1.5	-
ELPEX	NR	-40	1.1	1.0	1.25	1.40	1.60	-	-	-	-	-
ELPEX-B	NR	-50	1.1	1.0	-	-	-	-	-	-	-	-
ELPEX-B	CR	-15	-	1.0	1.0	1.0	-	-	-	-	-	-
ELPEX-S SN, NN, WN	NR	-40	1.1	1.0	1.25	1.40	1.60	-	-	-	-	-
ELPEX-S NX	VMQ	-40	1.1	1.0	1.0	1.0	1.0	1.1	1.25	1.4	1.6	-

- NR = natural rubber, natural-synthetic rubber mixture
- NBR = nitril-butadiene-rubber (Perbunan)
- HNBR = hydrated acrylonitrile butadiene rubber
- CR = chloroprene rubber (FRAS fire-resistant and anti-static)
- VMQ = silicone
- TPU = polyurethane

<sup>1)</sup> The N-EUPEX coupling is not suitable for shock loads when used at low temperatures.

$$\text{Coupling size } T_{KN} \geq T_N \cdot \text{FB} \cdot \text{FT}$$

In the case of ARPEX and ZAPEX coupling types, no temperature factor (FT = 1.0) need be taken into account.

### Coupling load at maximum and overload conditions

The maximum torque is the highest load acting on the coupling in normal operation. Maximum torques at a frequency of up to 25 times an hour are permitted and must be lower than the maximum coupling torque. Examples of maximum torque conditions are: Starting operations, stopping operations or usual operating conditions with maximum load.

$$T_{Kmax} \geq T_{Max} \cdot \text{FT}$$

Overload torques are maximum loads which occur only in combination with special, infrequent operating conditions. Examples of overload torque conditions are: Motor short circuit, emergency stop or blocking because of component breakage. Overload torques at a frequency of once a month are permitted and must be lower than the maximum overload torque of the coupling. The overload condition may last only a short while, i.e. fractions of a second.

$$T_{KOL} \geq T_{OL} \cdot \text{FT}$$

### Coupling load due to dynamic torque load

Applying the frequency factor FF, the dynamic torque load must be lower than the coupling fatigue torque.

Dynamic torque load

$$T_{KW} \geq T_W \cdot \text{FF}$$

Frequency of the dynamic torque load  $f_{err} \leq 10$  Hz frequency factor FF = 1.0

Frequency of the dynamic torque load  $f_{err} > 10$  Hz frequency factor FF =  $\sqrt{(f_{err}/10 \text{ Hz})}$

**For the ZAPEX and ARPEX series, the frequency factor is always FF = 1.0.**

# SELECTION OF THE COUPLING SIZE

E

## Checking the maximum speed

For all load situations  $n_{K_{max}} \geq n_{max}$

## Checking permitted shaft misalignment

For all load situations, the actual shaft misalignment must be less than the permitted shaft misalignment.

## Checking bore diameter, mounting geometry and coupling design

The check must be made on the basis of the dimension tables. The maximum bore diameter applies to parallel keyways to DIN 6885. For other keyway geometries, the maximum bore diameter can be reduced.

On request, couplings with adapted geometry can be provided.

## Coupling behavior under overload conditions

The ZAPEX, N-ARPEX, ARPEX, N-EUPEX, RUPEX and N-BIPEX coupling series can withstand overloads until the breakage of metal parts. These coupling series are designated as fail-safe.

The N-EUPEX DS, ELPEX-B, ELPEX-S and ELPEX coupling series throw overload. The elastomer element of these couplings is irreparably damaged without damage to metal parts when subjected to excessive overload.

These coupling series are designated as non-fail-safe. These types that fail can be fitted with a so-called fail-safe device. This additional component enables emergency operation, even after the rubber element of the coupling has been irreparably damaged.

## Checking shaft-hub connection

The torques specified in the tables of power ratings data of the coupling series do not necessarily apply to the shaft-hub connection. Depending on the shaft-hub connection, proof of form stability is required. Flender recommends obtaining proof of form strength by using calculation methods in accordance with the current state of the art.

Fitting recommendations for the shaft-hub connection are given in the **Appendix**.

The coupling hub is frequently fitted flush with the shaft end face. If the shaft projects, the risk of collision with other coupling parts must be checked. If the shaft is set back, in addition to the load-bearing capacity of the shaft-hub connection, the correct positioning of the hub must be ensured as well. If the bearing hub length is insufficient, restorative forces may cause tilting movements and so wear to and impairment of the axial retention. Also, the position of the set screw to be positioned on sufficient shaft or parallel key material must be noted.

Shaft-hub connection	Suggestion for calculation method
Keyway connection to DIN 6885-1	DIN 6892
Shrink fit	DIN 7190
Spline to DIN 5480	
Bolted flange connection	VDI 2230
Flange connection with close-fitting bolts	

## Checking low temperature and chemically aggressive environment

The minimum permitted coupling temperature is specified in the Temperature factor FT table. In the case of chemically aggressive environments, please consult the manufacturer.

# FEATURES OF THE STANDARD TYPE



Couplings	Features of the standard type
All coupling series except ARPEX clamping hubs and FLUDEX with keyway to ASME B17.1	Bore tolerance H7
N-ARPEX and ARPEX clamping hubs	Bore tolerance G6 (suitable for shaft tolerance h6)
FLUDEX couplings with keyway to ASME B17.1	Hollow shafts: bore tolerance K7 other parts: bore tolerance M7
All coupling series with bore diameter - imperial	Parallel keyway to ASME B17.1
Bore diameter metric in the case of ZAPEX, N-ARPEX and ARPEX coupling series as well as coupling hubs with applied brake disks or brake drums of the N-EUPEX and RUPEX series	Parallel keyway to DIN 6885-1 keyway width P9
Bore diameter metric in the case of the N-EUPEX, RUPEX, N-BIPEX, ELPEX-S, ELPEX-B, ELPEX, FLUDEX coupling series	Parallel keyway to DIN 6885-1 keyway width JS9
All coupling series except FLUDEX	Axial locking by means of set screw
FLUDEX coupling series	Axial lock by means of set screw or end washer
All coupling series	Balancing in accordance with half parallel key standard
ZAPEX, N-ARPEX, ARPEX, N-EUPEX, RUPEX, N-BIPEX, ELPEX-S, ELPEX-B and ELPEX coupling series	Balancing quality G16
FLUDEX coupling series	Balancing quality G6.3
SIPEX and BIPEX-S coupling series	Balancing quality G6.3 for 3600 rpm
All series	Unpainted
All series	Preservation with cleaning emulsion
FLUDEX couplings	Fuse 140 °C

## Configurator

The article number can be obtained with the help of the Configurator. The coupling can be selected in a product configurator and specified using selection menus.

The coupling can be selected via "Technical selection" (technical selection) or via "Direct selection" (via article-no.).

The Configurator is available under [flender.com](http://flender.com).





# TORSIONALLY RIGID GEAR COUPLINGS

## ZAPEX ZW SERIES



<b>General</b>	<b>4/3</b>
Benefits	4/3
Application	4/3
Design and configurations	4/4
Function	4/4
Technical specifications	4/5
-----	
Type ZWN	4/6
Type ZZS	4/8
Type ZZW	4/10
Type ZWH	4/12
Type ZWBT	4/13
Type ZWBG	4/14
Type ZWB	4/15
Type ZWTR	4/16
Type ZBR	4/17
Type ZWS	4/18
Type ZWNV	4/19
Type ZWSE	4/20
-----	
Customized hub design	4/21
-----	
Spare and wear parts	4/23
-----	



ZAPEX ZW  
**FLENDER**



# GENERAL

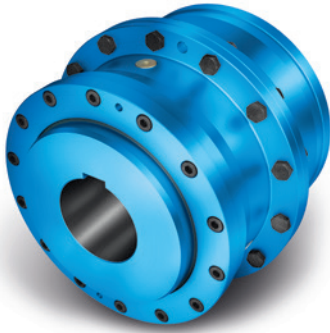

Coupling suitable for use in potentially explosive atmospheres.

Complies with the current ATEX Directive for:

CE  II 2G Ex h IIC T6 ... T5 Gb X

 II 2D Ex h IIIC T85 °C ... 100 °C Db X

 I M2 Ex h Mb X

4

## Benefits

ZAPEX gear couplings link machine shafts and compensate for shaft misalignment with weak restorative forces. High transmissible torque combined with compactness and light weight are characteristic of ZAPEX couplings. ZAPEX coupling types are constructed on a modular principle.

This means that application-specific solutions can be delivered quickly. ZAPEX couplings require very little maintenance. Regular grease or oil changes at the prescribed intervals prolongs the service life of the coupling.

## Application

ZAPEX couplings are especially suited for operation in harsh operating conditions, such as drives in the iron smelting or cement industry.

ZAPEX couplings are suitable for reverse operation and horizontal mounting positions and, in the case of type ZWNV, for vertical mounting positions.

# GENERAL

## Design and configurations

4

A ZAPEX coupling comprises two hub sections with external teeth which are mounted on the machine shafts. Each set of external teeth engages in a flanged socket with mating internal teeth. The flanged sleeves are connected via two flanges with close-fitting bolts. The teeth are lubricated with oil or grease. On the ZAPEX type ZW, DUO sealing rings are used to seal the tooth space. The DUO sealing rings prevent the lubricant from escaping and dirt from entering the tooth space. The parallel keyways must be sealed during assembly to prevent lubricant from escaping. Customized hub designs are described after the types.

Type	Description
ZWN	Standard type
ZZS	with adapter
ZZW	with intermediate shaft
ZWH	with coupling sleeve
ZWBT	with offset brake disk
ZWBG	with straight brake disk
ZWB	with brake drum
ZWTR	for rope drums
ZBR	with shear pins
ZWS	Clutch
ZWNV	Vertical type
ZWSE	Simple clutch-coupling combination

Further application-specific coupling types are available; dimension sheets for and information on these are available on request.

## Function

The torque is transmitted through the coupling teeth. The teeth are crowned, so angular displacement per tooth plane is possible. Radial displacement can be compensated for via the space VA between the tooth planes. The internal teeth of the flanged sleeves are significantly wider than the external teeth of the hub parts, permitting a relatively high axial misalignment.

A small angular misalignment on the coupling teeth results in an advantageous distribution of the lubricant film and a very low wear rate. This favorable condition can be deliberately set by aligning the drive with the machine shafts with a slight radial misalignment.

## Technical specifications

Power ratings						
Size	Rated torque	Maximum torque	Overload torque	Fatigue torque	Torsional stiffness ZW	Permitted axial shaft misalignment $\Delta K_a$
	$T_{KN}$ Nm	$T_{Kmax}$ Nm	$T_{KOL}$ Nm	$T_{KW}$ Nm	$C_{Tdyn}$ kNm/rad	
112	1300	2600	5200	520	2000	1.0
128	2500	5000	10000	1000	3600	1.0
146	4300	8600	17200	1720	6900	1.0
175	7000	14000	28000	2800	9360	1.0
198	11600	23200	46400	4640	15600	1.0
230	19000	38000	76000	7600	26300	1.0
255	27000	54000	108000	10800	33400	1.5
290	39000	78000	156000	15600	44000	1.5
315	54000	108000	216000	21600	64100	1.5
342	69000	138000	276000	27600	81600	1.5
375	98000	196000	392000	39200	115600	1.5
415	130000	260000	520000	52000	106000	1.5
465	180000	360000	720000	72000	134600	2.0
505	250000	500000	1000000	100000	168700	2.0
545	320000	640000	1280000	128000	216900	2.0
585	400000	800000	1600000	160000	263200	2.0
640	510000	1020000	2040000	204000	356000	2.0
690	660000	1320000	2640000	264000	431000	2.0
730	790000	1580000	3160000	316000	538000	2.0
780	1000000	2000000	4000000	400000	696000	3.0
852	1200000	2400000	4800000	480000	926000	3.0
910	1600000	3200000	6400000	640000	1118000	3.0
1020	1900000	3800000	7600000	760000	1339000	3.0
1080	2200000	4400000	8800000	880000	1605000	3.0
1150	2700000	5400000	10800000	1080000	2120000	3.0
1160	3350000	6700000	13400000	1340000	2474000	3.0
1240	3800000	7600000	15200000	1520000	3079000	3.0
1310	4600000	9200000	18400000	1840000	3693000	4.0
1380	5300000	10600000	21200000	2120000	4383000	4.0
1440	6250000	12500000	25000000	2500000	5056000	4.0
1540	7200000	14400000	28800000	2880000	6115000	4.0

In the case of type ZWTR, the rated torques which deviate from the above are specified in the dimension table.

The stated torsional stiffness "ZW" applies to coupling types ZWN and ZWNV.  
Torsional stiffness of the remaining types on request.

The axial misalignment  $\Delta K_a$  must be understood as the maximum permitted enlargement of the hub distance S of the coupling.

The axial misalignment for the types ZWBT, ZWBG and ZWNV is  $1/2 \cdot \Delta K_a$ .

#### Angular misalignment $\Delta K_w$

Types ZWN, ZZS, ZZW, ZWH, ZWB, ZBR, ZWS:  $\Delta K_w = 1^\circ$

Types ZWBT and ZWBG:  $\Delta K_w = 0.2^\circ$

Type ZWSE:  $\Delta K_w = 0.4^\circ$

#### Radial misalignment $\Delta K_r$

Types ZWN, ZZS, ZZW, ZWH, ZWB, ZBR, ZWS:

$\Delta K_r \leq VA \cdot \tan 1^\circ$

Types ZWBT and ZWBG:  $\Delta K_r \leq VA \cdot \tan 0,2^\circ$

Type ZWSE:  $\Delta K_r \leq VA \cdot 0.4^\circ$

For the tooth distance VA, see the relevant table for the subassembly.

# TYPE ZWN

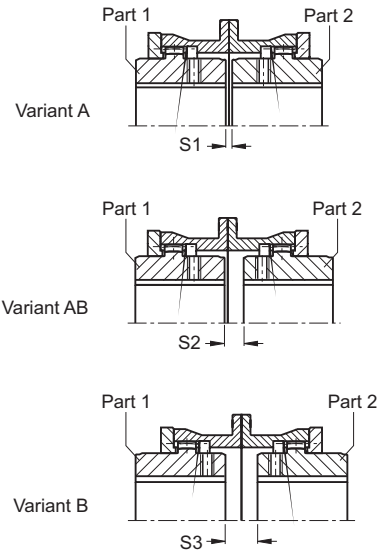
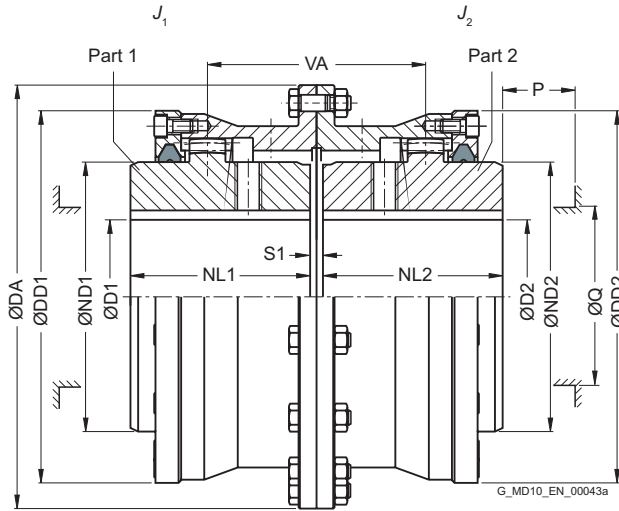

Size	Rated torque $T_{KN}$ Nm	Maximum speed $n_{Kmax}$ rpm	Dimensions in mm													Mass moment of inertia $J_1/J_2$ kgm <sup>2</sup>	Article no. <sup>1)</sup>			Weight $m$ kg
			D1, D2 Keyway DIN 6885-1		DA	ND1/ND2	NL1/NL2	DD1/DD2	S1	S2	S3	VA	Q	P	Type		A	B	AB	
			min.	max.																
112	1300	9400	0	49	143	65	50	110	6	-	-	56	50	35	0.007	2LC0300-0AA	2LC0300-0AB	2LC0300-0AC	5.8	
128	2500	8300	0	61	157	80	60	128	6	13	20	73	65	45	0.014	2LC0300-1AA	2LC0300-1AB	2LC0300-1AC	7.9	
146	4300	7300	0	72	177	95	75	146	6	13	20	88	75	45	0.021	2LC0300-2AA	2LC0300-2AB	2LC0300-2AC	11.5	
175	7000	6400	0	85	215	112	90	175	8	14	20	104	85	50	0.049	2LC0300-3AA	2LC0300-3AB	2LC0300-3AC	19	
198	11600	5500	0	100	237	135	100	198	8	19	30	119	110	50	0.086	2LC0300-4AA	2LC0300-4AB	2LC0300-4AC	26.5	
230	19000	4700	0	120	265	160	110	230	8	20	32	130	135	50	0.16	2LC0300-5AA	2LC0300-5AB	2LC0300-5AC	37	
255	27000	4100	0	140	294	185	125	255	10	25	40	150	160	50	0.26	2LC0300-6AA	2LC0300-6AB	2LC0300-6AC	49	
290	39000	3700	70	160	330	210	140	290	10	30	50	170	180	60	0.51	2LC0300-7AA	2LC0300-7AB	2LC0300-7AC	72	
315	54000	3300	80	175	366	230	160	315	10	30	50	190	200	60	0.81	2LC0300-8AA	2LC0300-8AB	2LC0300-8AC	99	
342	69000	3000	90	195	392	255	180	340	12	42	72	222	225	60	1.2	2LC0301-0AA	2LC0301-0AB	2LC0301-0AC	125	
375	98000	2700	100	220	430	290	200	375	12	42	72	242	260	60	2	2LC0301-1AA	2LC0301-1AB	2LC0301-1AC	170	
415	130000	2500	120	240	478	320	220	415	12	74	136	294	285	80	3.1	2LC0301-2AA	2LC0301-2AB	2LC0301-2AC	225	
465	180000	2200	140	270	528	360	240	465	16	96	176	336	325	80	5.2	2LC0301-3AA	2LC0301-3AB	2LC0301-3AC	300	
505	250000	2000	160	300	568	400	260	505	16	106	196	366	365	80	7.7	2LC0301-4AA	2LC0301-4AB	2LC0301-4AC	380	
545	320000	1800	180	330	620	440	280	545	16	126	236	406	405	80	12	2LC0301-5AA	2LC0301-5AB	2LC0301-5AC	490	
585	400000	1700	210	360	660	480	310	585	20	150	280	460	445	80	17	2LC0301-6AA	2LC0301-6AB	2LC0301-6AC	620	
640	510000	1600	230	360	738	480	330	640	20	149	278	445	475	90	25	2LC0301-7AA	2LC0301-7AB	2LC0301-7AC	780	
			>360	390		520						475							27	800
690	660000	1450	250	390	788	520	350	690	20	166	312	475	515	90	35	2LC0301-8AA	2LC0301-8AB	2LC0301-8AC	950	
			>390	420		560						515							38	980
730	790000	1350	275	420	834	560	380	730	20	180	340	515	555	90	48	2LC0302-0AA	2LC0302-0AB	2LC0302-0AC	1150	
			>420	450		600						555							52	1200

### Configurable variants <sup>1)</sup>

- ØD1 Without finished bore  
With finished bore
- ØD2 Without finished bore  
With finished bore

<sup>1)</sup> To identify complete item numbers specifying the available finish boring options and – if necessary – further order options, please use our configurators on [flender.com](http://flender.com).

↗ For online configuration on [flender.com](http://flender.com), click on the item no.

Size	Rated torque $T_{KN}$ Nm	Maximum speed $n_{Kmax}$ rpm	Dimensions in mm													Mass moment of inertia $J_1/J_2$ kgm <sup>2</sup>	Article no. <sup>1)</sup>			Weight $m$ kg
			D1, D2 Keyway DIN 6885-1		DA	ND1/ND2	NL1/NL2	DD1/DD2	S1	S2	S3	VA	Q	P	Type					
			min.	max.											A		B	AB		
780	1000000	1250	300	450	900	600	400	780	25	176	327	576	555	110	68	2LC0302-1AA	2LC0302-1AB	2LC0302-1AC	1450	
			>450	490		650							595		77				1450	
852	1200000	1150	325	490	970	650	420	850	25	185	345	605	595	110	100	2LC0302-2AA	2LC0302-2AB	2LC0302-2AC	1750	
			>490	535		710							655		110				1800	
910	1600000	1050	350	535	1030	710	450	910	25	215	405	665	655	110	140	2LC0302-3AA	2LC0302-3AB	2LC0302-3AC	2100	
			>535	570		750							695		145				2150	
1020	1900000	1000	375	570	1112	750	480	1020	25	213	401	693	695	130	200	2LC0302-4AA	2LC0302-4AB	2LC0302-4AC	2600	
			>570	600		800							735		220				2800	
1080	2200000	950	400	600	1162	800	500	1080	30	226	422	726	735	135	255	2LC0302-5AA	2LC0302-5AB	2LC0302-5AC	3100	
			>600	650		860							795		285				3200	
1150	2700000	900	425	650	1222	860	520	1150	30	238	446	758	795	135	330	2LC0302-6AA	2LC0302-6AB	2LC0302-6AC	3600	
			>650	705		930							865		380				3700	
1160	3350000	850	450	650	1292	860	550	1160	30	260	490	810	795	135	420	2LC0302-7AA	2LC0302-7AB	2LC0302-7AC	4000	
			>650	705		990							865		450				4100	
1240	3800000	800	>705	750	1400	930	580	1160	30	260	490	810	910	155	500	2LC0302-8AA	2LC0302-8AB	2LC0302-8AC	4300	
			>705	750		930							865		580				4900	
1310	4600000	750	>750	800	1470	990	610	1160	35	265	495	875	910	155	620	2LC0303-0AA	2LC0303-0AB	2LC0303-0AC	5000	
			>750	800		1055							975		700				5300	
1380	5300000	700	>800	850	1540	1055	640	1160	35	275	515	915	1030	155	730	2LC0303-1AA	2LC0303-1AB	2LC0303-1AC	5600	
			>800	850		1120							910		930				6500	
1440	6250000	670	>850	890	1600	1055	670	1160	35	295	555	965	975	155	1000	2LC0303-2AA	2LC0303-2AB	2LC0303-2AC	6800	
			>850	890		1170							1030		1050				6900	
1540	7200000	630	>890	940	1710	1120	700	1160	35	275	515	975	1080	175	1150	2LC0303-3AA	2LC0303-3AB	2LC0303-3AC	7100	
			>890	940		1240							975		1200				7500	
1540	7200000	630	>940	995	1710	1120	700	1160	35	275	515	975	1030	175	1250	2LC0303-3AA	2LC0303-3AB	2LC0303-3AC	7600	
			>940	995		1310							1150		1450				7700	
1540	7200000	630	>940	995	1710	1120	700	1160	35	275	515	975	1030	175	1300	2LC0303-3AA	2LC0303-3AB	2LC0303-3AC	8200	
			>940	995		1310							1220		1900				8800	

Configurable variants <sup>1)</sup>

- ØD1 Without finished bore  
With finished bore
- ØD2 Without finished bore  
With finished bore

Notes

- Mass moments of inertia apply to a coupling half with maximum bore diameter.
- Weights apply to the entire coupling with maximum bores.
- Q Diameter required for renewing the sealing rings.  
P Length required for renewing the sealing rings.

Ordering example

- ZAPEX ZWN coupling, size 146, variant A
- Part 1: Bore 40H7mm, keyway to DIN 6885-1 P9 and set screw
- Part 2: Bore 45K7 mm, keyway to DIN 6885-1 P9 and set screw

Article no.: 2LC0300-2AA99-0AA0-Z L0W+M1A+M13

<sup>1)</sup> To identify complete item numbers specifying the available finish boring options and – if necessary – further order options, please use our configurators on [flender.com](http://flender.com).

↗ For online configuration on [flender.com](http://flender.com), click on the item no.

# TYPE ZZS

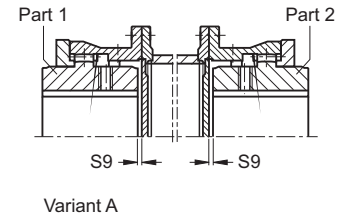
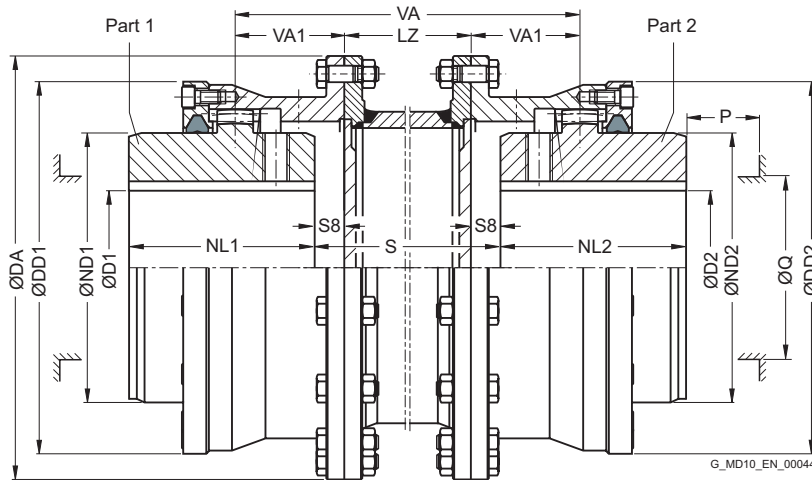

Variant B

Size	Rated torque $T_{KN}$ Nm	Dimensions in mm												➤ Article no. <sup>1)</sup>		Weight each 100 mm pipe	
		D1, D2 Keyway DIN 6885-1		DA	ND1/ND2	NL1/NL2	DD1/DD2	S8	S9	VA1	Q	P	LZ	Type		m	kg
		min.	max.											A	B		
112	1300	0	49	143	65	50	110	3	3	28	50	35	120	2LC0300-0AD	2LC0300-0AE	0.8	9.4
128	2500	0	61	157	80	60	128	10	3	36.5	65	45	120	2LC0300-1AD	2LC0300-1AE	1.3	12.5
146	4300	0	72	177	95	75	146	10	3	44	75	45	120	2LC0300-2AD	2LC0300-2AE	1.8	17
175	7000	0	85	215	112	90	175	10	4	52	85	50	130	2LC0300-3AD	2LC0300-3AE	2.3	27.5
198	11600	0	100	237	135	100	198	15	4	59.5	110	50	130	2LC0300-4AD	2LC0300-4AE	3.5	37
230	19000	0	120	265	160	110	230	16	4	65	135	50	130	2LC0300-5AD	2LC0300-5AE	4.5	50
255	27000	0	140	294	185	125	255	20	5	75	160	50	140	2LC0300-6AD	2LC0300-6AE	6.3	68
290	39000	70	160	330	210	140	290	25	5	85	180	60	140	2LC0300-7AD	2LC0300-7AE	7.2	93
315	54000	80	175	366	230	160	315	25	5	95	200	60	180	2LC0300-8AD	2LC0300-8AE	9.1	135
342	69000	90	195	392	255	180	340	36	6	111	225	60	180	2LC0301-0AD	2LC0301-0AE	12	170
375	98000	100	220	430	290	200	375	36	6	121	260	60	180	2LC0301-1AD	2LC0301-1AE	15	220
415	130000	120	240	478	320	220	415	68	6	147	285	80	200	2LC0301-2AD	2LC0301-2AE	17	295
465	180000	140	270	528	360	240	465	88	8	168	325	80	200	2LC0301-3AD	2LC0301-3AE	19	380
505	250000	160	300	568	400	260	505	98	8	183	365	80	200	2LC0301-4AD	2LC0301-4AE	24	470
545	320000	180	330	620	440	280	545	118	8	203	405	80	220	2LC0301-5AD	2LC0301-5AE	30	640
585	400000	210	360	660	480	310	585	140	10	230	445	80	220	2LC0301-6AD	2LC0301-6AE	33	780
640	510000	230	360	738	480	330	640	139	10.0	239.5	445	90	250	2LC0301-7AD	2LC0301-7AE	39	1010
		>360	390		520						475						1050
690	660000	250	390	788	520	350	690	156	10.0	258	475	90	250	2LC0301-8AD	2LC0301-8AE	48	1200
		>390	420		560						515						1250
730	790000	275	420	834	560	380	730	170	10.0	280	515	90	250	2LC0302-0AD	2LC0302-0AE	51	1450
		>420	450		600						555						1500
780	1000000	300	450	900	600	400	780	163.5	12.5	288	555	110	280	2LC0302-1AD	2LC0302-1AE	55	1850
		>450	490		650						595						1900

## Configurable variants <sup>1)</sup>

- ØD1 Without finished bore  
With finished bore
- ØD2 Without finished bore  
With finished bore

<sup>1)</sup> To identify complete item numbers specifying the available finish boring options and – if necessary – further order options, please use our configurators on [flender.com](http://flender.com).

➤ For online configuration on [flender.com](http://flender.com), click on the item no.



Size	Rated torque $T_{KN}$ Nm	Dimensions in mm												Article no. <sup>1)</sup>		Weight each 100 mm pipe m		
		D1, D2 Keyway DIN 6885-1		DA	ND1/ND2	NL1/NL2	DD1/DD2	S8	S9	VA1	Q	P	LZ	Type	A	B	kg	m
		min.	max.															
852	1200000	325	490	970	650	420	850	172.5	12.5	302.5	595	110	280	2LC0302-2AD	2LC0302-2AE	68	2300	
		>490	535		710						655						2400	
910	1600000	350	535	1030	710	450	910	202.5	12.5	332.5	655	110	280	2LC0302-3AD	2LC0302-3AE	94	2800	
		>535	570		750						695						2850	
1020	1900000	375	570	1112	750	480	1020	200.5	12.5	346.5	695	130	380	2LC0302-4AD	2LC0302-4AE			
1080	2200000	400	600	1162	800	500	1080	211	15.0	363	735	135	380	2LC0302-5AD	2LC0302-5AE			
		>600	650		860						795							
1150	2700000	425	650	1222	860	520	1150	223	15.0	379	795	135	380	2LC0302-6AD	2LC0302-6AE			
		>650	705		930						865							
1160	3350000	450	650	1292	860	550	1160	245	15.0	405	795	135	380	2LC0302-7AD	2LC0302-7AE			
		>650	705		930						865							
1240	3800000	475	705	1400	930	580	1240	235	15.0	415	865	155	400	2LC0302-8AD	2LC0302-8AE			
		>705	750		990						910							
1310	4600000	500	705	1470	930	610	1310	247.5	17.5	437.5	865	155	400	2LC0303-0AD	2LC0303-0AE			
		>705	750		1055						910							
1380	5300000	525	750	1540	990	640	1380	257.5	17.5	457.5	910	155	400	2LC0303-1AD	2LC0303-1AE			
		>750	800		1120						1030							
1440	6250000	550	800	1600	1055	670	1440	277.5	17.5	482.5	975	155	400	2LC0303-2AD	2LC0303-2AE			
		>800	850		1170						1080							
1540	7200000	575	850	1710	1120	700	1540	257.5	17.5	487.5	1030	175	600	2LC0303-3AD	2LC0303-3AE			
		>850	890		1240						1150							
		>940	995		1310		1610				1220							

**Configurable variants <sup>1)</sup>**

- ØD1 Without finished bore  
With finished bore
- ØD2 Without finished bore  
With finished bore

**Notes**

- Mass moments of inertia apply to a coupling half with maximum bore diameter.
- Weights apply to maximum bores and an adapter length of LZ min.
- Weights from size 1020 on request.
- $VA = 2 \cdot VA1 + LZ$
- Mass moment of inertia on request.
- Maximum speed, limited by weight and critical adapter speed, on request.
- Q Diameter required for renewing the sealing rings.  
P Length required for renewing the sealing rings.

**Ordering example**

- ZAPEX ZZS coupling, size 146, variant B
- Part 1: Bore 40H7mm, keyway to DIN 6885-1 P9 and set screw
- Part 2: Bore 45K7 mm, keyway to DIN 6885-1 P9 and set screw

Article no.: 2LC0300-2AE99-0AZ0-Z L0W+M1A+Q0Y+M13  
Plain text to Q0Y: 250 mm (dimension S)

<sup>1)</sup> To identify complete item numbers specifying the available finish boring options and – if necessary – further order options, please use our configurators on [fender.com](http://fender.com).

➤ For online configuration on [fender.com](http://fender.com), click on the item no.

# TYPE ZZW

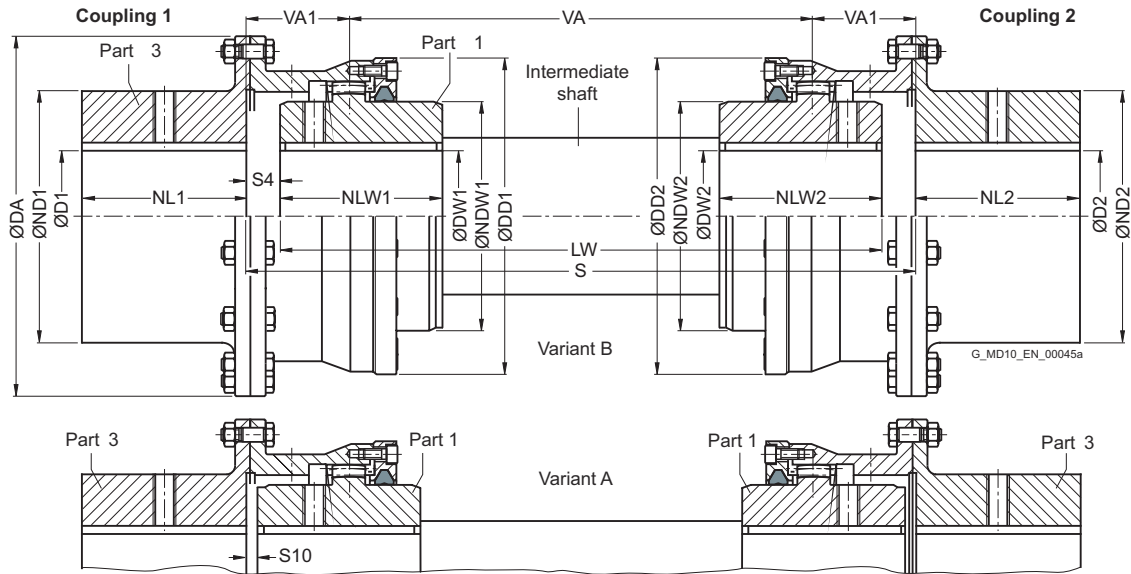

Size	Rated torque $T_{KN}$ Nm	Dimensions in mm											Article no. <sup>1)</sup>		Weight  m kg	
		D1, D2 Keyway DIN 6885-1		DA	ND1/ ND2	NL1/ NL2/ NLW1/ NLW2	DW1, DW2 Keyway DIN 6885-1		NDW1/ NDW2	DD1/ DD2	S4	S10	VA1	Type		
		min.	max.				min.	max.						A		B
112	1300	20	61	143	80	50	0	49	65	110	12.5	12.5	37.5	2LC0300-0BD	2LC0300-0BE	5.1
128	2500	25	72	157	95	60	0	61	80	128	12.5	5.5	39	2LC0300-1BD	2LC0300-1BE	6.8
146	4300	30	85	177	112	75	0	72	95	146	12.5	5.5	46.5	2LC0300-2BD	2LC0300-2BE	9.8
175	7000	35	100	215	135	90	0	85	112	175	12.5	6.5	54.5	2LC0300-3BD	2LC0300-3BE	16.5
198	11600	40	120	237	160	100	0	100	135	198	17.5	6.5	62	2LC0300-4BD	2LC0300-4BE	23
230	19000	50	140	265	185	110	0	120	160	230	18.5	6.5	67.5	2LC0300-5BD	2LC0300-5BE	32
255	27000	60	160	294	210	125	0	140	185	255	23.5	8.5	78.5	2LC0300-6BD	2LC0300-6BE	43
290	39000	70	175	330	230	140	70	160	210	290	28.5	8.5	88.5	2LC0300-7BD	2LC0300-7BE	61
315	54000	80	195	366	255	160	80	175	230	315	28.5	8.5	98.5	2LC0300-8BD	2LC0300-8BE	86
342	69000	90	220	392	290	180	90	195	255	340	39.5	9.5	114.5	2LC0301-0BD	2LC0301-0BE	115
375	98000	100	240	430	320	200	100	220	290	375	39.5	9.5	124.5	2LC0301-1BD	2LC0301-1BE	150
415	130000	120	270	478	360	220	120	240	320	415	71.5	9.5	150.5	2LC0301-2BD	2LC0301-2BE	205
465	180000	140	300	528	400	240	140	270	360	465	91.5	11.5	171.5	2LC0301-3BD	2LC0301-3BE	275
505	250000	160	330	568	440	260	160	300	400	505	102.5	12.5	187.5	2LC0301-4BD	2LC0301-4BE	350
545	320000	180	360	620	480	280	180	330	440	545	122.5	12.5	207.5	2LC0301-5BD	2LC0301-5BE	450
585	400000	210	360	660	480	310	210	360	480	585	144.5	14.5	234.5	2LC0301-6BD	2LC0301-6BE	540
		>360	390		520		570									
640	510000	230	390	738	520	330	230	360	480	640	143.5	14.5	244	2LC0301-7BD	2LC0301-7BE	700
		>390	420		560		>360	390								520
690	660000	250	420	788	560	350	250	390	520	690	160.5	14.5	262.5	2LC0301-8BD	2LC0301-8BE	850
		>420	450		600		>390	420								560
730	790000	275	450	834	600	380	275	420	560	730	176	16	286	2LC0302-0BD	2LC0302-0BE	1050
		>450	490		650		>420	450								600
780	1000000	300	490	900	650	400	300	450	600	780	171.5	20.5	296	2LC0302-1BD	2LC0302-1BE	1300
		>490	535		710		>450	490								650

### Configurable variants <sup>1)</sup>

- ØD1 Without finished bore  
With finished bore
- ØD2 Without finished bore  
With finished bore

<sup>1)</sup> To identify complete item numbers specifying the available finish boring options and – if necessary – further order options, please use our configurators on [flender.com](http://flender.com).

↗ For online configuration on [flender.com](http://flender.com), click on the item no.

Size	Rated torque $T_{KN}$ Nm	Dimensions in mm												Article no. <sup>1)</sup>		Weight  m kg
		D1, D2 Keyway DIN 6885-1		DA	ND1/ ND2	NL1/ NL2/ NLW1/ NLW2	DW1, DW2 Keyway DIN 6885-1		NDW1/ NDW2	DD1/ DD2	S4	S10	VA1	Type		
		min.	max.				min.	max.						A	B	
852	1200000	325	535	970	710	420	325	490	650	850	180.5	20.5	310.5	2LC0302-2BD	2LC0302-2BE	1550
		>535	570		750		>490	535	710							1650
910	1600000	350	570	1030	750	450	350	535	710	910	210.5	20.5	340.5	2LC0302-3BD	2LC0302-3BE	1900
		>570	600		800		>535	570	750							2000
1020	1900000	375	600	1112	800	480	375	570	750	1020	210.5	22.5	356.5	2LC0302-4BD	2LC0302-4BE	2300
		>600	650		860		>570	600	800							2500
1080	2200000	400	650	1162	860	500	400	600	800	1080	221	25	373	2LC0302-5BD	2LC0302-5BE	2750
		>650	705		930		>600	650	860							2900
1150	2700000	425	650	1222	860	520	425	650	860	1150	233	25	389	2LC0302-6BD	2LC0302-6BE	3100
		>650	705		930		>650	705	930							3200
1160	3350000	450	705	1292	930	550	450	650	860	1160	255	25	415	2LC0302-7BD	2LC0302-7BE	3400
		>705	750		990		>650	705	930							3600
1240	3800000	475	705	1400	930	580	475	705	930	1240	245	25	425	2LC0302-8BD	2LC0302-8BE	3700
		>705	750		990		>705	750	990							4000
1310	4600000	500	750	1470	990	610	500	705	930	1310	257.5	27.5	447.5	2LC0303-0BD	2LC0303-0BE	4200
		>750	800		1055		>705	750	990							4400
1380	5300000	525	800	1540	1055	640	525	750	990	1380	267.5	27.5	467.5	2LC0303-1BD	2LC0303-1BE	4600
		>800	850		1120		>750	800	1055							4900
1440	6250000	550	850	1600	1120	670	550	800	1055	1440	287.5	27.5	492.5	2LC0303-2BD	2LC0303-2BE	5100
		>850	890		1170		>800	850	1120							5300
1540	7200000	575	890	1710	1170	700	575	850	1120	1540	267.5	27.5	497.5	2LC0303-3BD	2LC0303-3BE	5600
		>890	940		1240		>850	890	1170							5700
		>940	1040		1390		>940	995	1310	1610						7700
																8100
																8900

Configurable variants <sup>1)</sup>

- ØD1 Without finished bore  
With finished bore
- ØD2 Without finished bore  
With finished bore

Notes

- $VA = S - 2 \cdot VA1$
- Mass moment of inertia on request.
- Weights apply to either coupling 1 or 2 with maximum bore diameter, without intermediate shaft.
- Maximum speed, limited by weight and critical speed of intermediate shaft, on request.

<sup>1)</sup> To identify complete item numbers specifying the available finish boring options and – if necessary – further order options, please use our configurators on [flender.com](http://flender.com).

↗ For online configuration on [flender.com](http://flender.com), click on the item no.

Ordering example

- Coupling 1:  
ZAPEX ZZW coupling, size 146, variant B,  
Part 3: Bore D1 = 45K7 mm, keyway to DIN 6885-1 P9 and set screw, Part 1: Bore DW1 = 45H7 mm, keyway to DIN 6885-1 P9 and set screw.

Article no.: 2LC0300-2BE99-0AA0-Z L1A+M1A+L13

- Intermediate shaft:  
Intermediate shaft for ZAPEX coupling ZZW, size 146,  
length LW = 570 mm, for shaft distance S = 595 mm  
shaft journal Ø45p6 x 75 long; keyway DIN 6885-1.

Article no.: 2LC0308-8XX00-0AA0-Z Y99

Plain text to Y99: DW1 = 45p6 mm, NLW1 = 75 mm,  
DW2 = 45p6 mm, NLW2 = 75 mm, LW = 570 mm

- Coupling 2:  
ZAPEX ZZW coupling, size 146, variant B,  
Part 1: Bore DW2 = 45H7 mm, keyway to DIN 6885-1 P9 and set screw, Part 3: Bore D2 = 45K7 mm, keyway to DIN 6885-1 P9 and set screw.

Article no.: 2LC0300-2BE99-0AA0-Z L1A+M1A+L13

# TYPE ZWH

4

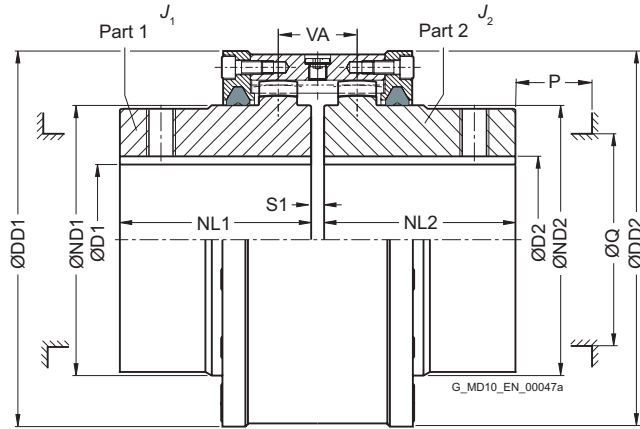

Size	Rated torque $T_{KN}$ Nm	Maximum speed $n_{Kmax}$ rpm	Dimensions in mm									Mass moment of inertia $J_1/J_2$ kgm <sup>2</sup>	Article no. <sup>1)</sup>	Weight $m$ kg
			D1, D2 Keyway DIN 6885-1		ND1/ND2	NL1/NL2	DD1/DD2	S1	VA	Q	P			
min.		max.												
112	1300	9400	0	49	65	50	110	6	28	50	35	0.003	2LC0300-0BB	3.5
128	2500	8300	0	61	80	60	128	6	30	65	45	0.007	2LC0300-1BB	5.1
146	4300	7300	0	72	95	75	146	6	33	75	45	0.012	2LC0300-2BB	7.8
175	7000	6400	0	85	112	90	175	8	46	85	50	0.031	2LC0300-3BB	13.5
198	11600	5500	0	100	135	100	198	8	48	110	50	0.056	2LC0300-4BB	20
230	19000	4700	0	120	160	110	230	8	50	135	50	0.11	2LC0300-5BB	28.5
255	27000	4100	0	140	185	125	255	10	55	160	50	0.18	2LC0300-6BB	38
290	39000	3700	70	160	210	140	290	10	58	180	60	0.35	2LC0300-7BB	56
315	54000	3300	80	175	230	160	315	10	62	200	60	0.55	2LC0300-8BB	74
342	69000	3000	90	195	255	180	340	12	70	225	60	0.82	2LC0301-0BB	95
375	98000	2700	100	220	290	200	375	12	72	260	60	1.3	2LC0301-1BB	130
415	130000	2500	120	240	320	220	415	12	76	285	80	2.3	2LC0301-2BB	175
465	180000	2200	140	270	360	240	465	16	90	325	80	4	2LC0301-3BB	245
505	250000	2000	160	300	400	260	505	16	92	365	80	6	2LC0301-4BB	310
545	320000	1800	180	330	440	280	545	16	96	405	80	8.8	2LC0301-5BB	390
585	400000	1700	210	360	480	310	585	20	102	445	80	13	2LC0301-6BB	500
640	510000	1600	230	360	480	330	640	20	105	445	90	18	2LC0301-7BB	620
			>360	390	520					475		19.5		650
690	660000	1450	250	390	520	350	690	20	108	475	90	25.5	2LC0301-8BB	760
			>390	420	560					515		28		790
730	790000	1350	275	420	560	380	730	20	112	515	90	35	2LC0302-0BB	920
			>420	450	600					555		39		950
780	1000000	1250	300	450	600	400	780	25	120	555	110	48	2LC0302-1BB	1150
			>450	490	650					595		57		

### Configurable variants <sup>1)</sup>

- ØD1 Without finished bore  
With finished bore
- ØD2 Without finished bore  
With finished bore

### Notes

- Larger size couplings on request.
- Mass moments of inertia apply to a coupling half with maximum bore diameter.
- Weights apply to the entire coupling with maximum bores.
- Q Diameter required for renewing the sealing rings.  
P Length required for renewing the sealing rings.

### Ordering example

- ZAPEX ZWH coupling, size 146
- Part 1: Bore 40H7mm, keyway to DIN 6885-1 P9 and set screw
- Part 2: Bore 45K7 mm, keyway to DIN 6885-1 P9 and set screw

Article no.: 2LC0300-2BB99-0AA0-Z L0W+M1A+M13

<sup>1)</sup> To identify complete item numbers specifying the available finish boring options and – if necessary – further order options, please use our configurators on [flender.com](http://flender.com).

↗ For online configuration on [flender.com](http://flender.com), click on the item no.

# TYPE ZWBT

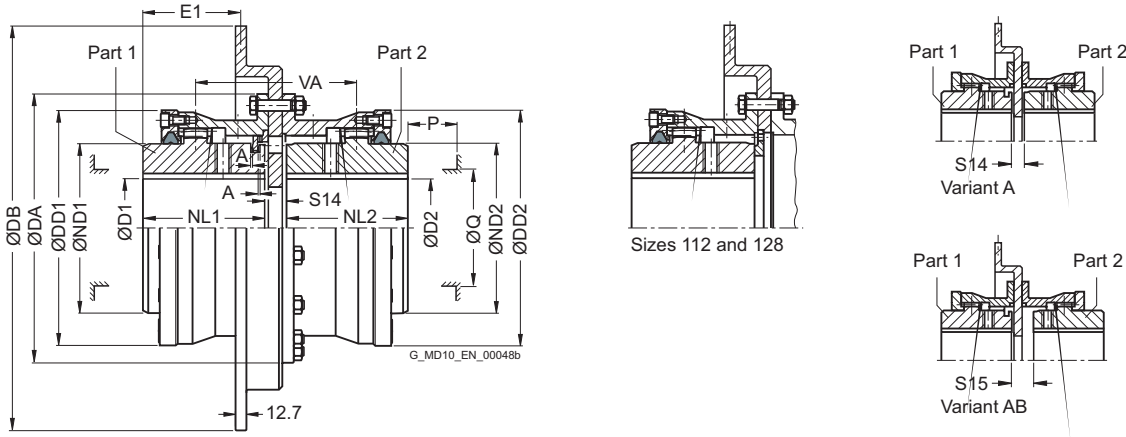

Size	Rated torque $T_{KN}$ Nm	Maximum speed $n_{Kmax}$ rpm	Dimensions in mm														Brake disk		Article no. <sup>1)</sup>		Weight $m$ kg	
			D1 Keyway DIN 6885-1 min.   max.		D2 Keyway DIN 6885-1 min.   max.		DA	ND1/ ND2	NL1/ NL2	DD1/ DD2	S14	S15	A	VA	Q	P	DB	E1	Type			
																			A	AB		
112	1300	3800	0	49	0	49	143	65	50	110	20	-	0.5	70	50	35	300	32.35	2LC0300-0AS	2LC0300-0AT	13	
		23									-	73		356			22.35	2LC0300-0AS	2LC0300-0AT	16.5		
128	2500	3200	0	61	0	61	157	80	60	128	23.5	30.5	0.5	90.5	65	45	356	32.85	2LC0300-1AS	2LC0300-1AT	19	
		20.5									27.5	87.5		406			29.85	2LC0300-1AS	2LC0300-1AT	21.5		
146	4300	2800	0	65	0	72	177	95	75	146	19	26	0.5	101	75	45	406	43.35	2LC0300-2AS	2LC0300-2AT	25	
		22									29	104		457			46.35	2LC0300-2AS	2LC0300-2AT	30		
175	7000	2800	0	80	0	85	215	112	90	175	21	27	0.5	117	85	50	406	59.35	2LC0300-3AS	2LC0300-3AT	33	
		24									30	120		457			62.35	2LC0300-3AS	2LC0300-3AT	38		
198	11600	2200	0	95	0	100	237	135	100	198	24	30	0.5	120	110	50	514	62.35	2LC0300-3AS	2LC0300-3AT	43	
		24									35	135		457			72.35	2LC0300-4AS	2LC0300-4AT	46		
230	19000	2200	0	117	0	120	265	160	110	230	24	36	0.5	146	135	50	514	82.35	2LC0300-5AS	2LC0300-5AT	62	
		24									36	146		610			82.35	2LC0300-5AS	2LC0300-5AT	73		
255	27000	2200	0	140	0	140	294	185	125	255	26	41	1	166	160	50	514	98.35	2LC0300-6AS	2LC0300-6AT	73	
		26									41	166		610			98.35	2LC0300-6AS	2LC0300-6AT	84		
290	39000	1850	70	155	70	160	330	210	140	290	26	46	1	186	180	60	610	113.35	2LC0300-7AS	2LC0300-7AT	110	
		29									49	189		711			116.35	2LC0300-7AS	2LC0300-7AT	125		
315	54000	1850	80	175	80	175	366	230	160	315	26	46	1	206	200	60	610	133.35	2LC0300-8AS	2LC0300-8AT	135	
		29									49	209		711			136.35	2LC0300-8AS	2LC0300-8AT	150		
342	69000	1600	90	195	90	195	392	255	180	340	31	61	1	241	225	60	711	157.35	2LC0301-0AS	2LC0301-0AT	180	
375	98000	1600	100	220	100	220	430	290	200	375	31	61	1	261	260	60	711	177.35	2LC0301-1AS	2LC0301-1AT	220	
415	130000	1400	120	240	120	240	478	320	220	415	37	99	1	319	285	80	812	203.35	2LC0301-2AS	2LC0301-2AT	320	
465	180000	1400	140	270	140	270	528	360	240	465	41	121	1	361	325	80	812	225.35	2LC0301-3AS	2LC0301-3AT	400	

### Configurable variants <sup>1)</sup>

- ØD1 Without finished bore  
With finished bore
- ØD2 Without finished bore  
With finished bore

### Notes

- Mass moment of inertia on request.
- Weights apply to maximum bores.
- Variant limited in displacement and axial movement. Max. displacement 0.2°.
- Q Diameter required for renewing the sealing rings.  
P Length required for renewing the sealing rings.

### Ordering example

- ZAPEX ZWBT coupling, size 146, variant A, brake disk diameter DB = 457 mm
- Part 1: Bore 40H7mm, keyway to DIN 6885-1 P9 and set screw
- Part 2: Bore 45K7 mm, keyway to DIN 6885-1 P9 and set screw

Article no.: 2LC0300-2AS99-0BA0-Z L0W+M1A+M13

<sup>1)</sup> To identify complete item numbers specifying the available finish boring options and – if necessary – further order options, please use our configurators on [flender.com](http://flender.com).

➤ For online configuration on [flender.com](http://flender.com), click on the item no.

# TYPE ZWBG

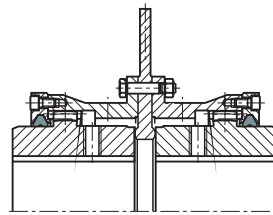
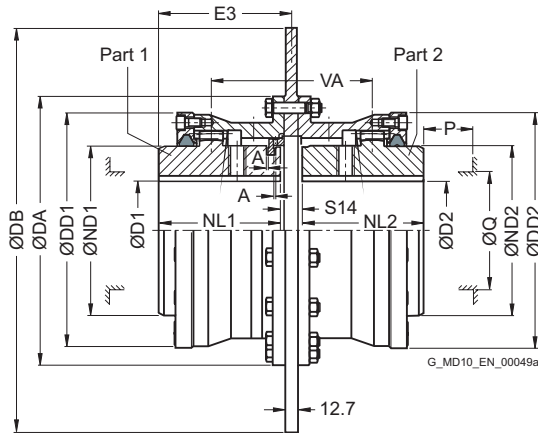

Sizes 112 and 128

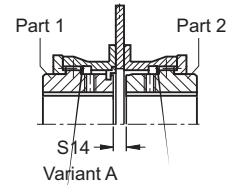

Variant A

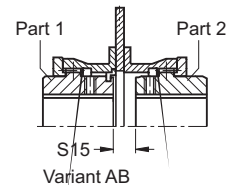

Variant AB

Size	Rated torque $T_{KN}$ Nm	Maximum speed $n_{Kmax}$ rpm	Dimensions in mm														Brake disk		Article no. <sup>1)</sup>		Weight $m$ kg
			D1 Keyway DIN 6885-1 min. max.		D2 Keyway DIN 6885-1 min. max.		DA	ND1/ ND2	NL1/ NL2	DD1/ DD2	S14	S15	A	VA	Q	P	DB	E3	Type		
			A	AB																	
112	1300	3800	0	49	0	49	143	65	50	110	19	-	0.5	69	50	35	300	59.5	2LC0300-0AU	2LC0300-0AV	13
		3200									22	-		72			356	61	2LC0300-0AU	2LC0300-0AV	16
128	2500	3200	0	61	0	61	157	80	60	128	22	29	0.5	89	65	45	356	71	2LC0300-1AU	2LC0300-1AV	18
		2800									19	26		86			406	69.5	2LC0300-1AU	2LC0300-1AV	20.5
146	4300	2800	0	65	0	72	177	95	75	146	19	26	0.5	101	75	45	406	84.5	2LC0300-2AU	2LC0300-2AV	24
		2500									22	29		104			457	86	2LC0300-2AU	2LC0300-2AV	28.5
175	7000	2800	0	80	0	85	215	112	90	175	21	27	0.5	117	85	50	406	100.5	2LC0300-3AU	2LC0300-3AV	31
		2500									24	30		120			457	102	2LC0300-3AU	2LC0300-3AV	35
198	11600	2500	0	95	0	100	237	135	100	198	24	35	0.5	135	110	50	457	112	2LC0300-4AU	2LC0300-4AV	43
		2200									24	35		135			514	112	2LC0300-4AU	2LC0300-4AV	47
230	19000	2200	0	117	0	120	265	160	110	230	24	36	0.5	146	135	50	514	122	2LC0300-5AU	2LC0300-5AV	58
		1850									24	36		146			610	122	2LC0300-5AU	2LC0300-5AV	66
255	27000	2200	0	140	0	140	294	185	125	255	26	41	1	166	160	50	514	138	2LC0300-6AU	2LC0300-6AV	69
		1850									26	41		166			610	138	2LC0300-6AU	2LC0300-6AV	77
290	39000	1850	70	155	70	160	330	210	140	290	26	46	1	186	180	60	610	153	2LC0300-7AU	2LC0300-7AV	100
		1600									29	49		189			711	154.5	2LC0300-7AU	2LC0300-7AV	110
315	54000	1850	80	175	80	175	366	230	160	315	26	46	1	206	200	60	610	173	2LC0300-8AU	2LC0300-8AV	130
		1600									29	49		209			711	174.5	2LC0300-8AU	2LC0300-8AV	140
342	69000	1600	90	195	90	195	392	255	180	340	31	61	1	241	225	60	711	195.5	2LC0301-0AU	2LC0301-0AV	165
375	98000	1600	100	220	100	220	430	290	200	375	31	61	1	261	260	60	711	215.5	2LC0301-1AU	2LC0301-1AV	205
415	130000	1400	120	240	120	240	478	320	220	415	37	99	1	319	285	80	812	238.5	2LC0301-2AU	2LC0301-2AV	280
465	180000	1400	140	270	140	270	528	360	240	465	41	121	1	361	325	80	812	260.5	2LC0301-3AU	2LC0301-3AV	360

### Configurable variants <sup>1)</sup>

- ØD1 Without finished bore  
With finished bore
- ØD2 Without finished bore  
With finished bore

### Notes

- Mass moment of inertia on request.
- Weights apply to maximum bores.
- Variant limited in displacement and axial movement. Max. displacement 0.2°.
- Modified brake disk dimensions on request
- Q Diameter required for renewing the sealing rings.  
P Length required for renewing the sealing rings.

### Ordering example

- ZAPEX ZWBG coupling, size 146, variant A, brake disk diameter DB = 457 mm
- Part 1: Bore 40H7mm, keyway to DIN 6885-1 P9 and set screw
- Part 2: Bore 45K7 mm, keyway to DIN 6885-1 P9 and set screw

Article no.: 2LC0300-2AU99-0BA0-Z L0W+M1A+M13

<sup>1)</sup> To identify complete item numbers specifying the available finish boring options and – if necessary – further order options, please use our configurators on [flender.com](http://flender.com).

↗ For online configuration on [flender.com](http://flender.com), click on the item no.

# TYPE ZWB

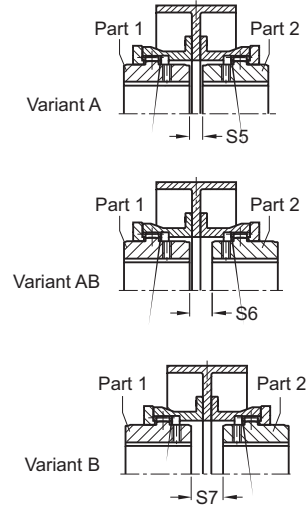
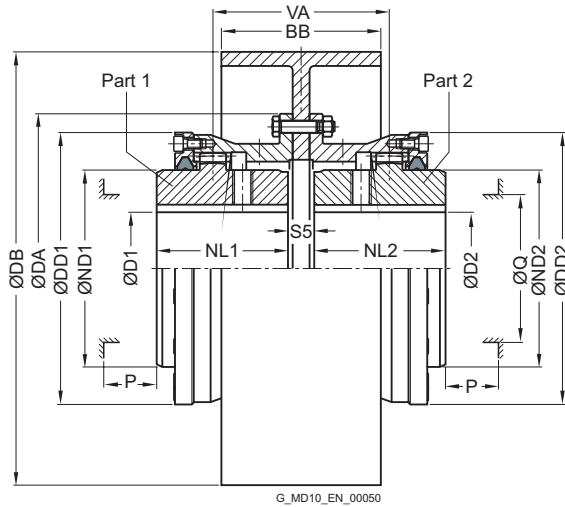

Size	Rated torque $T_{KN}$ Nm	Maximum speed $n_{Kmax}$ rpm	Dimensions in mm													Brake disk		Article no. <sup>1)</sup>			Weight $m$ kg
			D1, D2 Keyway DIN 6885-1		DA	ND1/ND2	NL1/NL2	DD1/DD2	S5	S6	S7	VA	Q	P	DB	BB	Type				
			min.	max.													A	B	AB		
128	2500	2500	0	61	157	80	60	128	16	23	30	83	60	45	200	75	2LC0300-1AW	2LC0300-1AX	2LC0300-1BA	12.5	
		16							23	30	83	250			95	2LC0300-1AW					2LC0300-1AX
146	4300	2000	0	72	177	95	75	146	16	23	30	98	75	45	250	95	2LC0300-2AW	2LC0300-2AX	2LC0300-2BA	19	
		18							25	32	100	315			118	2LC0300-2AW					2LC0300-2AX
175	7000	1600	0	85	215	112	90	175	20	26	32	116	85	50	315	118	2LC0300-3AW	2LC0300-3AX	2LC0300-3BA	33	
		22							28	34	118	400			150	2LC0300-3AW					2LC0300-3AX
198	11600	1600	0	100	237	135	100	198	20	31	42	131	110	50	315	118	2LC0300-4AW	2LC0300-4AX	2LC0300-4BA	41	
		22							33	44	133	400			150	2LC0300-4AW					2LC0300-4AX
230	19000	1250	0	120	265	160	110	230	22	34	46	144	135	50	400	150	2LC0300-5AW	2LC0300-5AX	2LC0300-5BA	64	
		23							35	47	145	500			190	2LC0300-5AW					2LC0300-5AX
255	27000	1000	0	140	294	185	125	255	25	40	55	165	160	50	500	190	2LC0300-6AW	2LC0300-6AX	2LC0300-6BA	95	
		28							43	58	168	630			236	2LC0300-6AW					2LC0300-6AX
290	39000	1000	70	160	330	210	140	290	28	48	68	188	180	60	630	236	2LC0300-7AW	2LC0300-7AX	2LC0300-7BA	160	
		28							48	68	188	710			265	2LC0300-7AW					2LC0300-7AX

### Configurable variants <sup>1)</sup>

- ØD1 Without finished bore  
With finished bore
- ØD2 Without finished bore  
With finished bore

### Notes

- Mass moment of inertia on request.
- Weights apply to maximum bores.
- Q Diameter required for renewing the sealing rings.  
P Length required for renewing the sealing rings.

### Ordering example

- ZAPEX ZWB coupling, size 146, variant A, brake disk diameter DB = 315 mm, BB = 118 mm
- Part 1: Bore 40H7mm, keyway to DIN 6885-1 P9 and set screw
- Part 2: Bore 45K7 mm, keyway to DIN 6885-1 P9 and set screw

Article no.: 2LC0300-2AW99-0BA0-Z L0W+M1A+M13

<sup>1)</sup> To identify complete item numbers specifying the available finish boring options and – if necessary – further order options, please use our configurators on [flender.com](http://flender.com).

↗ For online configuration on [flender.com](http://flender.com), click on the item no.

# TYPE ZWTR

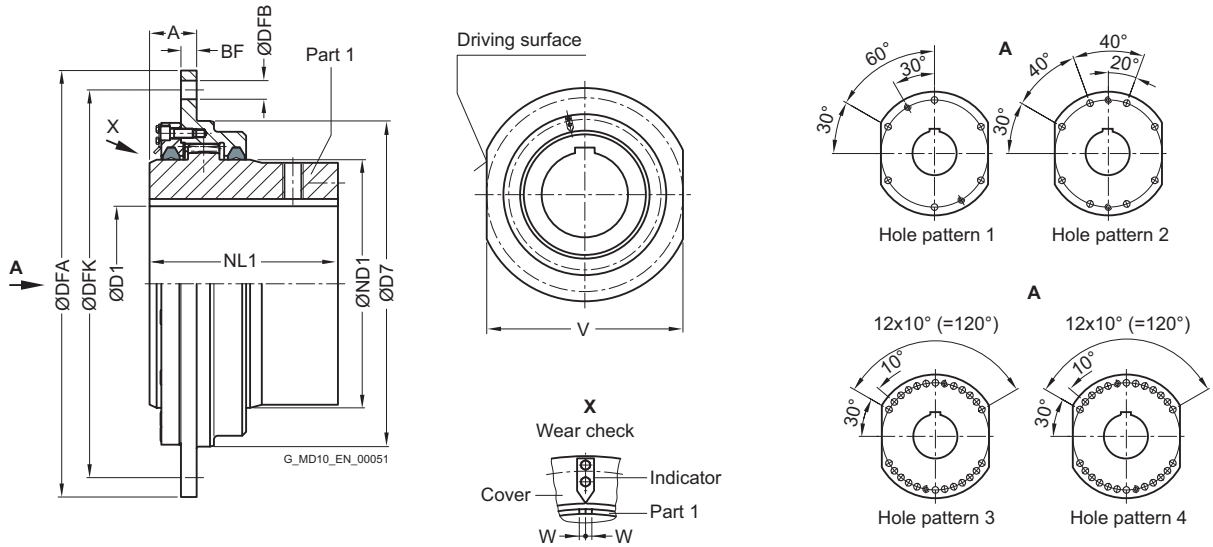

Size	Rated torque $T_{KN}$	Max. perm. radial load N	Dimensions in mm													Article no. <sup>1)</sup>	Weight m kg
			D1 Keyway DIN 6885-1		ND1	NL1	DFA	D7	V	A	BF	DFK	DFB	Hole pattern	Perm. wear W		
			min.	max.													
198	14500	32500	0	95	135	125	340	220	300	45	15	300	15	1	2	2LC0300-4BN	25
230	17500	36500	0	110	160	130	360	240	320	45	15	320	15	1	2	2LC0300-5BN	30
255	24000	45500	0	125	185	145	380	260	340	45	15	340	19	1	2	2LC0300-6BN	35
290 <sup>2)</sup>	31500	50000	0	145	210	170	400	280	360	45	15	360	19	1	3	2LC0300-7BN	45
315	42000	70000	0	160	230	175	420	310	380	60	20	380	24	1	3	2LC0300-8BN	60
342 <sup>2)</sup>	55000	90000	0	180	255	185	450	340	400	60	20	400	24	1	3	2LC0301-0BN	70
375	78000	110000	0	200	290	220	510	400	460	60	20	460	24	1	3	2LC0301-1BN	100
415 <sup>2)</sup>	104000	150000	0	220	320	240	550	420	500	60	20	500	24	1	3	2LC0301-2BN	130
465 <sup>2)</sup>	155000	165000	0	250	360	260	580	450	530	60	20	530	24	2	4	2LC0301-3BN	160
505 <sup>2)</sup>	235000	200000	0	275	400	315	650	530	580	65	25	600	24	2	4	2LC0301-4BN	240
545 <sup>2)</sup>	390000	325000	0	300	440	350	680	560	600	65	25	630	24	3	4	2LC0301-5BN	320
585 <sup>2)</sup>	460000	380000	0	330	480	380	710	600	640	81	35	660	28	4	4	2LC0301-6BN	400
640 <sup>2)</sup>	600000	420000	0	360	520	410	780	670	700	81	35	730	28	4	4	2LC0301-7BN	510
730 <sup>2)</sup>	880000	500000	0	415	600	450	850	730	760	81	35	800	28	4	5	2LC0302-0BN	690

### Configurable variants <sup>1)</sup>

- ØD1 Without finished bore  
With finished bore

### Notes

- Total wear must not exceed 1 x W.
- Mass moment of inertia on request.
- Weights apply to maximum bores.

### Ordering example

- ZAPEX ZWTR coupling, size 198, bore 80H7 mm, keyway to DIN 6885-1 P9 and set screw.

Article no.: 2LC0300-4BN90-0AA0-Z L1J

<sup>1)</sup> To identify complete item numbers specifying the available finish boring options and – if necessary – further order options, please use our configurators on [flender.com](http://flender.com).

<sup>2)</sup> These sizes have connection dimensions according to SEB 666 212.

↗ For online configuration on [flender.com](http://flender.com), click on the item no.



# TYPE ZBR

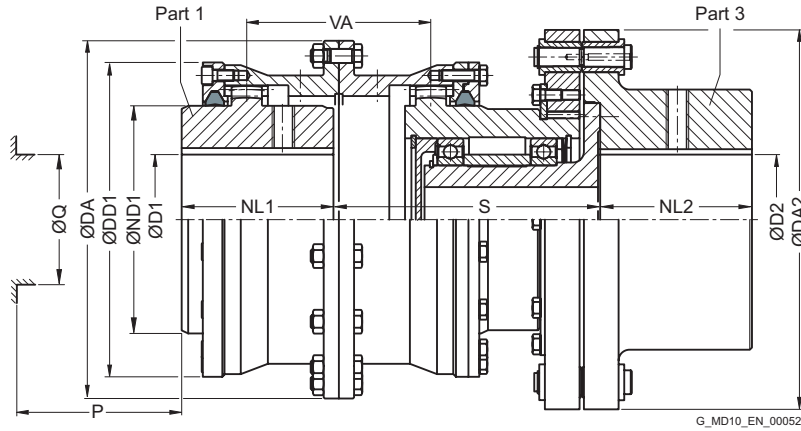

Size	Rated torque $T_{KN}$ Nm	Max. shear torque $T_{BR}$ Nm	Maximum speed $n_{Kmax}$ rpm	Dimensions in mm												Article no. <sup>1)</sup>	Weight $m$ kg	
				D1 Keyway DIN 6885-1		D2 Keyway DIN 6885-1		DA	ND1	NL1/ NL2	DA2	DD1	S	VA	Q			P
				min.	max.	min.	max.											
112	1300	1690	9400	0	49	0	60	143	65	50	170	110	115	56	50	35	2LC0300-0BH	14.5
128	2500	3250	8300	0	61	0	75	157	80	60	190	128	125	73	65	45	2LC0300-1BH	19
146	4300	5590	7300	0	72	0	90	177	95	75	205	146	140	88	75	45	2LC0300-2BH	27.5
175	7000	9100	6400	0	85	0	105	215	112	90	235	175	170	104	85	50	2LC0300-3BH	43
198	11600	15080	5500	0	100	0	120	237	135	100	285	198	185	119	110	50	2LC0300-4BH	67
230	19000	24700	4700	0	120	0	135	265	160	110	300	230	200	130	135	50	2LC0300-5BH	91
255	27000	35100	4100	0	140	0	155	294	185	125	335	255	215	150	160	50	2LC0300-6BH	120
290	39000	50700	3700	70	160	70	185	330	210	140	390	290	240	170	180	60	2LC0300-7BH	170
315	54000	70200	3300	80	175	80	200	366	230	160	415	315	257	190	200	60	2LC0300-8BH	215
342	69000	89700	3000	90	195	90	235	392	255	180	460	340	290	222	225	60	2LC0301-0BH	295
375	98000	127400	2700	100	220	100	240	430	290	200	495	375	300	242	260	60	2LC0301-1BH	380
415	130000	169000	2500	120	240	120	255	478	320	220	540	415	370	294	285	80	2LC0301-2BH	520
465	180000	234000	2200	140	270	140	285	528	360	240	635	465	400	336	325	80	2LC0301-3BH	720
505	250000	325000	2000	160	300	160	320	568	400	260	710	505	420	366	365	80	2LC0301-4BH	970
545	320000	416000	1800	180	330	180	370	620	440	280	800	545	460	406	405	80	2LC0301-5BH	1250
585	400000	520000	1700	210	360	210	390	660	480	310	860	585	500	460	445	80	2LC0301-6BH	1600
640	510000	663000	1600	230 >360	360 390	230	425	738 520	480 520	330	900	640	530	479 475	445 475	90	2LC0301-7BH	1850
690	660000	858000	1450	250 >390	390 420	250	450	788 560	520 560	350	1020	690	580	516 515	475 515	90	2LC0301-8BH	2600 2650
730	790000	1027000	1350	275 >420	420 450	275	485	834 600	560 600	380	1080	730	620	560 555	515 555	90	2LC0302-0BH	3200

### Configurable variants <sup>1)</sup>

- ØD1 Without finished bore  
With finished bore
- ØD2 Without finished bore  
With finished bore

### Notes

- Mass moment of inertia on request.
- Weights apply to maximum bores.
- Q Diameter required for renewing the sealing rings.  
P Length required for renewing the sealing rings.

### Ordering example

- ZAPEX coupling ZBR, size 146, ultimate moment  $T_{break} = 3500$  Nm
- Part 1: Bore 40H7mm, keyway to DIN 6885-1 P9 and set screw
- Part 3: Bore 45K7 mm, keyway to DIN 6885-1 P9 and set screw

Article no.: 2LC0300-2BH99-0BA0-Z L0W+M1A+M13+Y99  
Plain text to Y99:  $T_{break} = 3500$  Nm

<sup>1)</sup> To identify complete item numbers specifying the available finish boring options and – if necessary – further order options, please use our configurators on [fletcher.com](http://fletcher.com).

↗ For online configuration on [fletcher.com](http://fletcher.com), click on the item no.

# TYPE ZWS

4

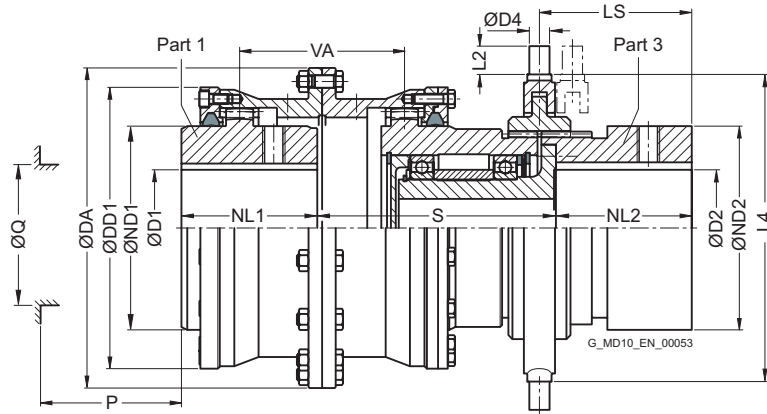

Size	Rated torque $T_{KN}$ Nm	Maximum speed $n_{Kmax}$ rpm	Dimensions in mm																Article no. <sup>1)</sup>	Weight $m$ kg		
			D1 Keyway DIN 6885-1		D2 Keyway DIN 6885-1		DA	ND1/ ND2	NL1/ NL2	DD1	S	VA	Q	P	LS	Shift ring		Switch size				
			min.	max.	min.	max.									L4	D4	L2	KSHN	KSZH			
128	2500	1500	0	61	0	50	157	80	60	128	135	73	65	45	70	150	15	14	14/11	-	2LC0300-1BK	16
146	4300	1300	0	72	0	50	177	95	75	146	131	88	75	45	86	180	16	16	16/12	-	2LC0300-2BK	22
175	7000	1100	0	85	0	70	215	112	90	175	165	104	85	50	101	180	16	16	16/12	-	2LC0300-3BK	35
198	11600	960	0	100	0	80	237	135	100	198	182	119	110	50	116	210	20	18	18/13	-	2LC0300-4BK	52
230	19000	830	0	120	0	90	265	160	110	230	198	130	135	50	126	260	22	20	18/15	14/14	2LC0300-5BK	77
255	27000	750	0	140	0	115	294	185	125	255	215	150	160	50	142	300	25	22	21/17	16/17	2LC0300-6BK	98
290	39000	660	70	160	70	130	330	210	140	290	236	170	180	60	157	315	25	35	-	16/211	2LC0300-7BK	140
315	54000	600	80	175	80	140	366	230	160	315	257	190	200	60	182	360	30	24	-	18/18	2LC0300-8BK	200
342	69000	560	90	195	90	160	392	255	180	340	280	222	225	60	202	360	30	24	-	18/18	2LC0301-0BK	230
375	98000	510	100	220	100	180	430	290	200	375	292	242	260	60	222	430	34	26	-	24/20	2LC0301-1BK	340
415	130000	460	120	240	120	210	478	320	220	415	349	294	285	80	247	430	34	26	-	24/20	2LC0301-2BK	430
465	180000	410	140	270	140	230	528	360	240	465	380	336	325	80	267	-	-	-	-	-	2LC0301-3BK	570
505	250000	380	160	300	160	260	568	400	260	505	395	366	365	80	287	-	-	-	-	-	2LC0301-4BK	740
545	320000	350	180	330	180	270	620	440	280	545	460	406	405	80	315	-	-	-	-	-	2LC0301-5BK	1000

### Configurable variants <sup>1)</sup>

- ØD1 Without finished bore  
With finished bore
- ØD2 Without finished bore  
With finished bore

### Notes

- Mass moment of inertia on request.
- Weights apply to maximum bores.
- Pneumatically or hydraulically actuated switches also available.
- For engaging/disengaging during standstill.
- Part 3 should be mounted on the shaft while the shaft is disconnected and not being driven.
- KSHN Manual lever switch type KSHN to M4218  
KSZH Toothed rack type KSZH to M4215

### Ordering example

- ZAPEX ZWS coupling, size 146
- Part 1: Bore 40H7mm, keyway to DIN 6885-1 P9 and set screw
- Part 3: Bore 45K7 mm, keyway to DIN 6885-1 P9 and set screw

Article no.: 2LC0300-2BK99-0AA0-Z L0W+M1A+M13

<sup>1)</sup> To identify complete item numbers specifying the available finish boring options and – if necessary – further order options, please use our configurators on [flender.com](http://flender.com).

↗ For online configuration on [flender.com](http://flender.com), click on the item no.

# TYPE ZWNV

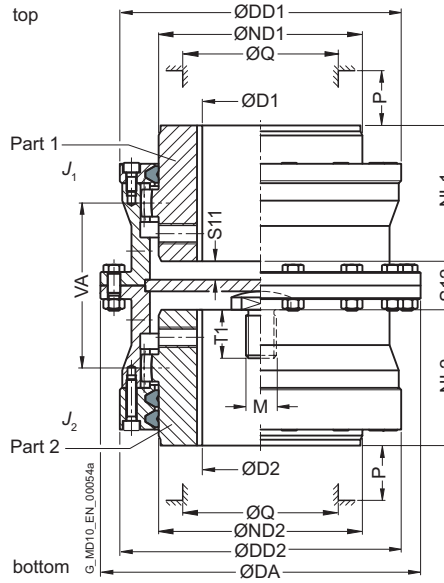

Size	Rated torque $T_{KN}$ Nm	Maximum speed $n_{Kmax}$ rpm	Dimensions in mm											Mass moment of inertia $J_1/J_2$ kgm <sup>2</sup>	Article no. <sup>1)</sup>	Weight $m$ kg
			D1, D2 Keyway DIN 6885-1 min.   max.	DA	ND1/ ND2	NL1/ NL2	DD1/ DD2	S11	S12	VA	Q	P				
128	2500	8300	0   61	157	80	60	128	6.5	26	73	65	45	0.015	2LC0300-1AH	9.1	
146	4300	7300	0   72	177	95	75	146	6	28	88	75	45	0.023	2LC0300-2AH	13	
175	7000	6400	0   85	215	112	90	175	5.5	33	104	85	50	0.055	2LC0300-3AH	22	
198	11600	5500	0   100	237	135	100	198	10	40	119	110	50	0.095	2LC0300-4AH	31	
230	19000	4700	0   120	265	160	110	230	11	32	130	135	50	0.18	2LC0300-5AH	43	
255	27000	4100	0   140	294	185	125	255	14	40	150	160	50	0.28	2LC0300-6AH	56	
290	39000	3700	70   160	330	210	140	290	19	50	170	180	60	0.55	2LC0300-7AH	81	
315	54000	3300	80   175	366	230	160	315	18	50	190	200	60	0.88	2LC0300-8AH	110	
342	69000	3000	90   195	392	255	180	340	29	72	222	225	60	1.3	2LC0301-0AH	140	
375	98000	2700	100   220	430	290	200	375	29	72	242	260	60	2.1	2LC0301-1AH	185	
415	130000	2500	120   240	478	320	220	415	60	136	294	285	80	3.4	2LC0301-2AH	250	
465	180000	2200	140   270	528	360	240	465	80	176	336	325	80	5.6	2LC0301-3AH	340	
505	250000	2000	160   300	568	400	260	505	89	196	366	365	80	8.2	2LC0301-4AH	420	

### Configurable variants <sup>1)</sup>

- ØD1 Without finished bore  
With finished bore
- ØD2 Without finished bore  
With finished bore

### Notes

- When ordering, state thread size M and thread length T1 of the thrust piece.
- Mass moments of inertia apply to a coupling half with maximum bore diameter.
- Weights apply to the entire coupling with maximum bores.
- Q Diameter required for renewing the sealing rings.  
P Length required for renewing the sealing rings.

### Ordering example

- ZAPEX ZWNV coupling, size 146, thread M10 x 20 deep
- Part 1: Bore 40H7mm, keyway to DIN 6885-1 P9 and set screw
- Part 2: Bore 45K7 mm, keyway to DIN 6885-1 P9 and set screw

Article no.: 2LC0300-2AH99-0AA0-Z L0W+M1A+M13+Y99  
Plain text to Y99: Thread M10 x 20 mm

<sup>1)</sup> To identify complete item numbers specifying the available finish boring options and – if necessary – further order options, please use our configurators on [flender.com](http://flender.com).

↗ For online configuration on [flender.com](http://flender.com), click on the item no.

# TYPE ZWSE

4

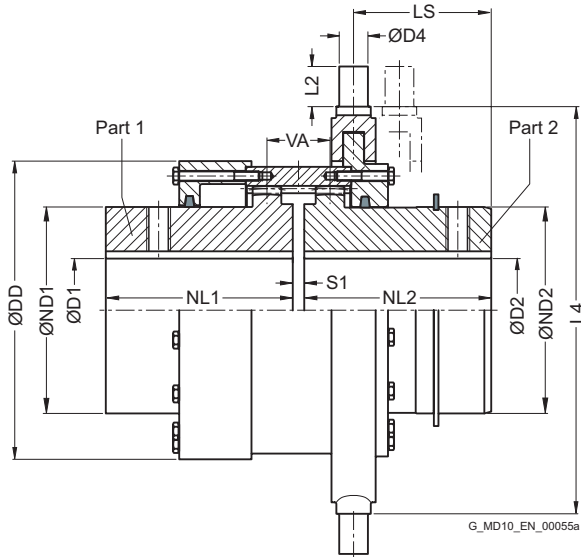

Size	Rated torque $T_{KN}$ Nm	Maximum speed $n_{Kmax}$ rpm	Dimensions in mm														Shift ring	Switch size		Article no. <sup>1)</sup>	Weight $m$ kg
			D1 Keyway DIN 6885-1 min.   max.		D2 Keyway DIN 6885-1 min.   max.		ND1	ND2	NL1	NL2	DD	S1	VA	LS	L4	D4		L2	KSHN		
128	2500	730	0	55	0	55	76.5	75	60	60	130	6	30	36.5	180	16	16	16	-	2LC0300-1BM	8.8
146	4300	630	0	69	0	65	91.5	90	75	75	150	6	33	50	210	20	18	18	-	2LC0300-2BM	13.5
175	7000	530	0	80	0	75	108	105	90	90	180	8	46	56.5	250	20	30	18	-	2LC0300-3BM	23
198	11600	470	0	95	0	95	130	130	100	100	204	8	48	64.5	260	22	20	18	-	2LC0300-4BM	32
230	19000	410	0	115	0	110	155	155	110	110	236	8	50	73	300	25	22	21	-	2LC0300-5BM	44
255	27000	370	0	135	0	130	180	180	125	125	260	10	55	82	355	25	35	24	-	2LC0300-6BM	63
290	39000	330	70	155	70	145	210	210	140	140	295	10	38	64.5	355	25	35	24	-	2LC0300-7BM	82
315	54000	300	80	170	80	165	230	230	160	160	325	10	42	76	355	25	35	24	-	2LC0300-8BM	105
342	69000	280	90	190	90	175	255	255	180	180	345	12	46	82	430	34	26	-	24	2LC0301-0BM	145
375	98000	250	100	210	100	200	280	280	200	200	378	12	48	90	430	34	26	-	24	2LC0301-1BM	180
415	130000	220	120	240	120	225	320	320	220	240	425	12	52	120	580	40	40	-	24	2LC0301-2BM	295
465	180000	200	140	270	140	250	360	360	240	260	470	16	60	150	580	40	40	-	24	2LC0301-3BM	350
505	250000	180	160	300	160	270	400	400	260	280	510	16	62	161	-	-	-	-	24	2LC0301-4BM	400

### Configurable variants <sup>1)</sup>

- ØD1 Without finished bore  
With finished bore
- ØD2 Without finished bore  
With finished bore

### Notes

- Mass moment of inertia on request.
- Weights apply to maximum bores.
- For engaging/disengaging during standstill.
- Part 2 should be mounted on the shaft while the shaft is disconnected and not being driven.
- Protect sliding surfaces from dirt and corrosion; sprayed with adhesive grease.

### Ordering example

- ZAPEX ZWSE coupling, size 146
- Part 1: Bore 40H7mm, keyway to DIN 6885-1 P9 and set screw,
- Part 2: Bore 45K7 mm, keyway to DIN 6885-1 P9 and set screw.

Article no.: 2LC0300-2BM99-0AA0-Z L0W+M1A+M13

<sup>1)</sup> To identify complete item numbers specifying the available finish boring options and – if necessary – further order options, please use our configurators on [flender.com](http://flender.com).

↗ For online configuration on [flender.com](http://flender.com), click on the item no.

# CUSTOMIZED HUB DESIGN

ZAPEX couplings can be provided with customized S-dimensions and hub lengths.

The entire dimension S results from the sum of the individual measurements SF1 and SF2. SF1 and SF2 are the measurements from the interstice of the coupling ring flange up to the beginning of the respective hub. As standard SF1 and SF2 are identical to each other and the entire S-dimension arises in accordance with them.

SF1 and SF2 can be chosen different on customer request, however the minimal and maximum values of the following table have to be observed. Within these limits the measurements SF1 and SF2 may be chosen freely.

The distance VA of the coupling teeth, the permitted bore diameter and the hub diameter remain unchanged.

By stating the hub S-dimension and both hub lengths the coupling is completely described.

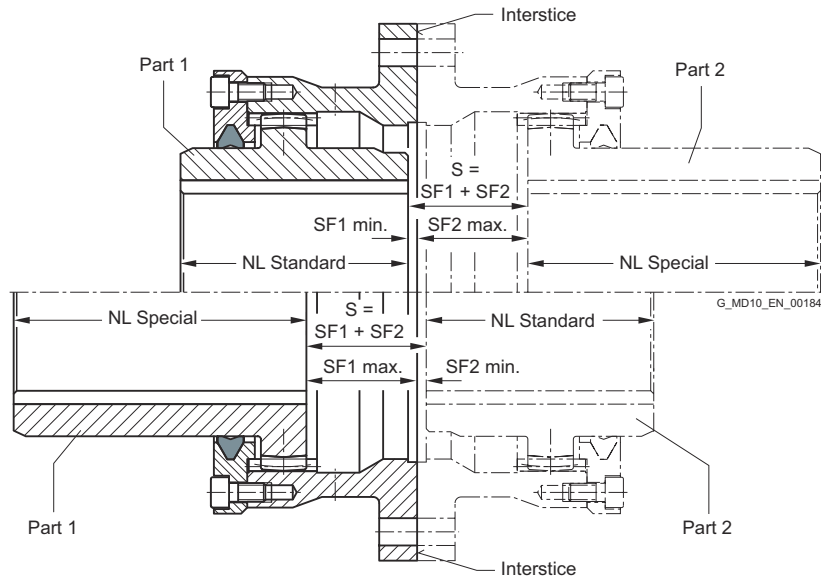

Geometric data			
Size	Standard hub length	Minimal dimension SF1 or SF2 mm	Maximum dimension SF1 or SF2 mm
	NL mm		
112	50	3	23
128	60	3	30.5
146	75	3	36.5
175	90	4	43
198	100	4	49.5
230	110	4	54
255	125	5	62.5
290	140	5	71
315	160	5	79
342	180	6	94
375	200	6	103
415	220	6	127
465	240	8	146
505	260	8	160

The minimal hub lengths are not to fall below the standard hub lengths. If there's no other possibility, for hub lengths smaller than standard hub lengths the order codes "Y50" for part 1 and "Y51" for part 2 must be stated in plain text.

## Article number

The Article number of the respective ZAPEX coupling type must be supplemented with "-Z" and order codes for non standard SF-dimensions (order code "Y38" for part 1 and "Y39" for part 2). For no standard hub lengths the order codes "Y40" to "Y49" must be specified (see table Page 4/22).

## Ordering example

- ZAPEX coupling ZWN 175, variant A
- Hub left: Bore D1 = 70H7 mm, keyway to DIN 6885-1 P9 and set screw; NL1 = 160 mm; SF1 = 10 mm
- Hub right: Bore D2 = 75H7 mm, keyway to DIN 6885-1 P9 and set screw; NL2 = 100 mm; SF2 = 25 mm

Article no.: 2LC0300-3AA99-0AA0-Z L1G M1H Y38 Y39 Y41 Y46

Plain text to Y38: SF1 = 10 mm

Plain text to Y39: SF2 = 25 mm

Plain text to Y46: NL1 = 160 mm

Plain text to Y41: NL2 = 100 mm

# CUSTOMIZED HUB DESIGN

Order code for hub prolongations (Y4). (Std-NL = Standard hub length)

4

Part 1		
Selected (special) hub length min.	max.	Order code (specification of hub length in plain text)
>Std-NL	$\leq 1.25 \cdot \text{Std-NL}$	Y40
>1.25 · Std-NL	$\leq 1.5 \cdot \text{Std-NL}$	Y42
>1.5 · Std-NL	$\leq 1.75 \cdot \text{Std-NL}$	Y44
>1.75 · Std-NL	$\leq 2 \cdot \text{Std-NL}$	Y46
>2 · Std-NL		Y48

Part 2		
Selected (special) hub length min.	max.	Order code (specification of hub length in plain text)
>Std-NL	$\leq 1.25 \cdot \text{Std-NL}$	Y41
>1.25 · Std-NL	$\leq 1.5 \cdot \text{Std-NL}$	Y43
>1.5 · Std-NL	$\leq 1.75 \cdot \text{Std-NL}$	Y45
>1.75 · Std-NL	$\leq 2 \cdot \text{Std-NL}$	Y47
>2 · Std-NL		Y49

# SPARE AND WEAR PARTS

## DUO sealing rings

The DUO sealing rings are wear parts and must be replaced in accordance with the operating instructions.

Size	Hub diameter ND1/ND2 mm	Article No.
112	65	2LC0300-0XG00-0AA0
128	80	2LC0300-1XG00-0AA0
146	95	2LC0300-2XG00-0AA0
175	112	2LC0300-3XG00-0AA0
198	135	2LC0300-4XG00-0AA0
230	160	2LC0300-5XG00-0AA0
255	185	2LC0300-6XG00-0AA0
290	210	2LC0300-7XG00-0AA0
315	230	2LC0300-8XG00-0AA0
342	255	2LC0301-0XG00-0AA0
375	290	2LC0301-1XG00-0AA0
415	320	2LC0301-2XG00-0AA0
465	360	2LC0301-3XG00-0AA0
505	400	2LC0301-4XG00-0AA0
545	440	2LC0301-5XG00-0AA0
585	480	2LC0301-6XG00-0AA0
640	480	2LC0301-7XG10-0AA0
	520	2LC0301-7XG20-0AA0
690	520	2LC0301-8XG10-0AA0
	560	2LC0301-8XG20-0AA0
730	560	2LC0302-0XG10-0AA0
	600	2LC0302-0XG20-0AA0
780	600	2LC0302-1XG10-0AA0
	650	2LC0302-1XG20-0AA0
852	650	2LC0302-2XG10-0AA0
	710	2LC0302-2XG20-0AA0
910	710	2LC0302-3XG10-0AA0
	750	2LC0302-3XG20-0AA0

Size	Hub diameter ND1/ND2 mm	Article No.
1020	750	2LC0302-4XG10-0AA0
	800	2LC0302-4XG20-0AA0
1080	800	2LC0302-5XG10-0AA0
	860	2LC0302-5XG20-0AA0
1150	860	2LC0302-6XG10-0AA0
	930	2LC0302-6XG20-0AA0
1160	860	2LC0302-7XG10-0AA0
	930	2LC0302-7XG20-0AA0
1240	990	2LC0302-7XG30-0AA0
	930	2LC0302-8XG10-0AA0
1310	990	2LC0302-8XG20-0AA0
	1055	2LC0302-8XG30-0AA0
1380	930	2LC0303-0XG10-0AA0
	990	2LC0303-0XG20-0AA0
1440	1055	2LC0303-0XG30-0AA0
	1120	2LC0303-0XG40-0AA0
1540	990	2LC0303-1XG10-0AA0
	1055	2LC0303-1XG20-0AA0
1540	1120	2LC0303-1XG30-0AA0
	1170	2LC0303-1XG40-0AA0
1540	1120	2LC0303-2XG10-0AA0
	1170	2LC0303-2XG20-0AA0
1540	1240	2LC0303-2XG30-0AA0
	1240	2LC0303-2XG40-0AA0
1540	1120	2LC0303-3XG10-0AA0
	1170	2LC0303-3XG20-0AA0
1540	1240	2LC0303-3XG30-0AA0
	1310	2LC0303-3XG40-0AA0

## High-performance grease

Container	Content g	Article No.
Cartridge	300	FFA:00000501027

## Sealing compound

Container	Content ml	Article No.
Tube	60	FFA:000001443780





# TORSIONALLY RIGID GEAR COUPLINGS

## ZAPEX ZN SERIES



<b>General</b>	<b>5/3</b>
Benefits	5/3
Application	5/3
Design and configurations	5/4
Function	5/4
Technical specifications	5/5
<hr/>	
<b>Type ZNN</b>	<b>5/6</b>
<hr/>	
<b>Type ZNZS</b>	<b>5/7</b>
<hr/>	
<b>Type ZNW</b>	<b>5/8</b>
<hr/>	
<b>Type ZNBG</b>	<b>5/10</b>
<hr/>	
<b>Type ZNNA</b>	<b>5/12</b>
<hr/>	
<b>Type ZNZA</b>	<b>5/13</b>
<hr/>	
<b>Type ZNNV</b>	<b>5/14</b>
<hr/>	
<b>Type ZNN for axial displacement</b>	<b>5/15</b>
<hr/>	
<b>Customized hub design</b>	<b>5/16</b>
<hr/>	
<b>Type ZN – flange connection dimensions</b>	<b>5/18</b>
<hr/>	
<b>Spare and wear parts</b>	<b>5/19</b>
<hr/>	



ZAPEX ZN  
**FLENDER**



# GENERAL



Coupling suitable for use in potentially explosive atmospheres.

Complies with the current ATEX Directive for:

CE  II 2G Ex h IIC T6 ... T5 Gb X

 II 2D Ex h IIIC T85 °C ... 100 °C Db X

 I M2 Ex h Mb X

## Materials

- Hubs and flanged sleeves: Steel
- O ring: Perbunan
- Lubricant: Grease filling

## Benefits

ZAPEX gear couplings link machine shafts and compensate for shaft misalignment with weak restorative forces. High transmissible torque combined with compactness and light weight are characteristic of ZAPEX couplings. ZAPEX coupling types are constructed on a modular principle, so application-related solutions can be delivered quickly.

This coupling requires very little maintenance. Regular grease changes at the prescribed intervals prolong the service life of the coupling.

## Application

ZAPEX couplings are especially suited for operation in harsh operating conditions, such as drives in the iron smelting or cement industry.

ZAPEX couplings are suitable for reverse operation and horizontal mounting positions and, in the case of type ZNNV, for vertical mounting positions.

# GENERAL

## Design and configurations

A ZAPEX coupling comprises two hub sections with external teeth which are mounted on the machine shafts. The external teeth engage with a flanged sleeve with corresponding internal teeth. The flanged sleeves are connected via two flanges with close-fitting bolts. The teeth are lubricated with grease. On the ZAPEX type ZN, O-rings are used to seal the tooth space. The O-rings prevent the lubricant from escaping and dirt from entering the tooth space. The parallel keyways must be sealed during assembly to prevent lubricant from escaping. Customized hub designs are described after the types.

Type	Description
ZNN	Standard type
ZNZS	with adapter
ZNW	with intermediate shaft
ZNBG	with straight brake disk
ZNNA	With axial backlash limiter
ZNZA	With adapter and axial backlash limiter
ZNNV	Vertical type
ZNN	For axial displacement

Further application-specific coupling types are available; dimension sheets for and information on these are available on request.

## Function

The torque is transmitted through the coupling teeth. The teeth are crowned, so angular displacement per tooth plane is possible. Radial displacement can be compensated for via the space VA between the tooth planes. The internal teeth of the flanged sleeves are significantly wider than the external teeth of the hub parts, permitting a relatively high axial misalignment.

A small angular misalignment on the coupling teeth results in an advantageous distribution of the lubricant film in contact with the teeth and a very low wear rate. This favorable condition can be deliberately set by aligning the drive with the machine shafts with a slight radial misalignment.

## Technical specifications

Power ratings						
Size	Rated torque	Maximum torque	Overload torque	Fatigue torque	Torsional stiffness ZN	Permitted axial shaft misalignment $\Delta K_a$ mm
	$T_{KN}$ Nm	$T_{Kmax}$ Nm	$T_{KOL}$ Nm	$T_{KW}$ Nm	$C_{Tdyn}$ kNm/rad	
83	1020	2040	4080	408	500	1
107	2210	4420	8840	884	1400	1
130	4020	8040	16080	1600	2500	1
156	6600	13200	26400	2640	5800	1
181	11000	22000	44000	4400	9200	1
211	19200	38400	76800	7680	16600	1
250	30680	61360	122720	12270	27300	1
274	43550	87100	174200	17400	41500	1.5
307	61750	123500	247000	24700	61000	1.5
333	87100	174200	348400	34800	79000	1.5
364	117000	234000	468000	46800	99000	1.5
424	162500	325000	650000	64800	156000	1.5

The specified torsional stiffness "ZN" applies to coupling types ZNN, ZNNA, ZNNV and ZNN for axial displacement. Torsional stiffness of types ZNZS, ZNW, ZNBG and ZNZA on request.

The axial misalignment  $\Delta K_a$  must be understood as the maximum permitted enlargement of the hub distance S of the coupling.

The axial misalignment  $\Delta K_a$  does not apply to the types ZNNA, ZNNV, ZNBG and ZNZA.

### Angular misalignment $\Delta K_w$

Types ZNN, ZNZS, ZNW, ZNNV, ZNN for axial displacement:  $\Delta K_w = 0.5^\circ$   
Types ZNBG, ZNNA, ZNZA:  $\Delta K_w = 0.2^\circ$

### Radial misalignment $\Delta K_r$

Types ZNN, ZNZS, ZNW, ZNNV, ZNN for axial displacement:  $\Delta K_r \leq VA \cdot \tan 0.5^\circ$   
Types ZNBG, ZNNA, ZNZA:  $\Delta K_r \leq VA \cdot \tan 0.2^\circ$   
For the tooth distance VA, see the relevant table for the subassembly.

# TYPE ZNN

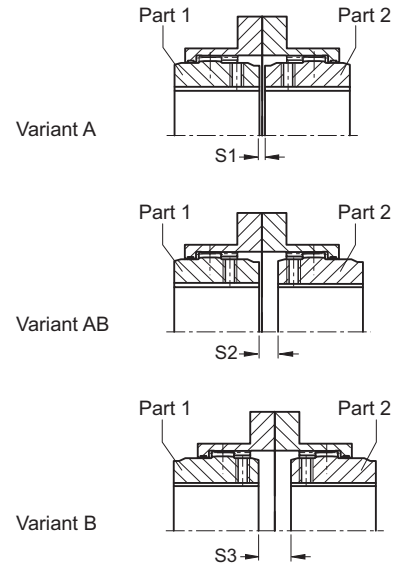
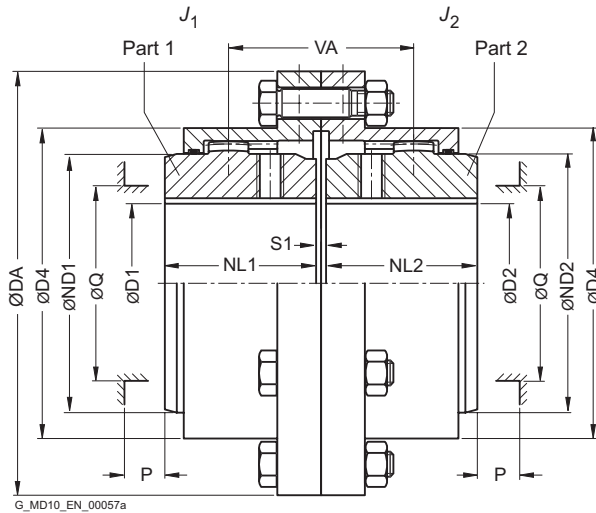

5

Size	Rated torque $T_{KN}$ Nm	Maximum speed $n_{Kmax}$ rpm	Dimensions in mm											Mass moment of inertia $J_1/J_2$ kgm <sup>2</sup>	Article no. <sup>1)</sup>			Weight $m$ kg	
			D1, D2 Keyway DIN 6885-1		DA	ND1/ND2	NL1/NL2	D4	S1	S2	S3	VA	Q		P	Type			
			min.	max.												A	B		AB
83	1020	8500	0	50	117	67	43	83	3	12	21	55	52	31	0.003	2LC0330-0AA	2LC0330-0AB	2LC0330-0AC	3.2
107	2210	7700	0	65	152	87	50	107	3	9	15	59	68	34	0.009	2LC0330-1AA	2LC0330-1AB	2LC0330-1AC	6.5
130	4020	6900	0	82	178	108	62	129.5	3	17	31	79	85	42	0.02	2LC0330-2AA	2LC0330-2AB	2LC0330-2AC	9.8
156	6600	6200	0	100	213	130	76	156	5	17	29	93	110	47	0.05	2LC0330-3AA	2LC0330-3AB	2LC0330-3AC	17.5
181	11000	5800	0	116	240	153	90	181	5	19	33	109	130	58	0.09	2LC0330-4AA	2LC0330-4AB	2LC0330-4AC	25.5
211	19200	5100	0	137	280	180	105	211	6	23	40	128	150	67	0.21	2LC0330-5AA	2LC0330-5AB	2LC0330-5AC	43
250	30680	4500	0	164	318	214	120	249.5	6	24	42	144	175	72	0.39	2LC0330-6AA	2LC0330-6AB	2LC0330-6AC	60
274	43550	4000	80	178	347	233	135	274	8	29	50	164	190	81	0.59	2LC0330-7AA	2LC0330-7AB	2LC0330-7AC	82
307	61750	3750	90	198	390	260	150	307	8	32	56	182	220	91	1.1	2LC0330-8AA	2LC0330-8AB	2LC0330-8AC	115
333	87100	3550	100	216	425.5	283	175	332.5	8	39	70	214	250	104	1.8	2LC0331-0AA	2LC0331-0AB	2LC0331-0AC	155
364	117000	3400	120	242	457	312	190	364	8	46	84	236	265	126	2.3	2LC0331-1AA	2LC0331-1AB	2LC0331-1AC	180
424	162500	3200	150	288	527	371	220	423.5	10	43	76	263	300	140	4.9	2LC0331-2AA	2LC0331-2AB	2LC0331-2AC	275

### Configurable variants <sup>1)</sup>

- ØD1 Without finished bore  
With finished bore
- ØD2 Without finished bore  
With finished bore

### Notes

- Mass moments of inertia apply to a coupling half with maximum bore diameter.
- Weights apply to the entire coupling with maximum bores.
- Q Diameter required for renewing the sealing rings.  
P Length required for renewing the sealing rings, aligning the coupling parts and tightening the set screw.

### Ordering example

- ZAPEX ZNN coupling, size 107, variant A
- Part 1: Bore 40H7mm, keyway to DIN 6885-1 P9 and set screw
- Part 2: Bore 45K7 mm, keyway to DIN 6885-1 P9 and set screw

Article no.: 2LC0330-1AA99-0AA0-Z L0W+M1A+M13

<sup>1)</sup> To identify complete item numbers specifying the available finish boring options and – if necessary – further order options, please use our configurators on [flender.com](http://flender.com).

↗ For online configuration on [flender.com](http://flender.com), click on the item no.

# TYPE ZNZZ

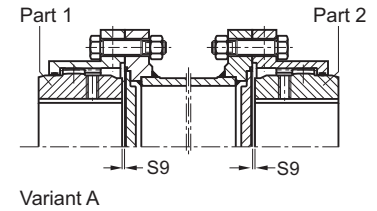
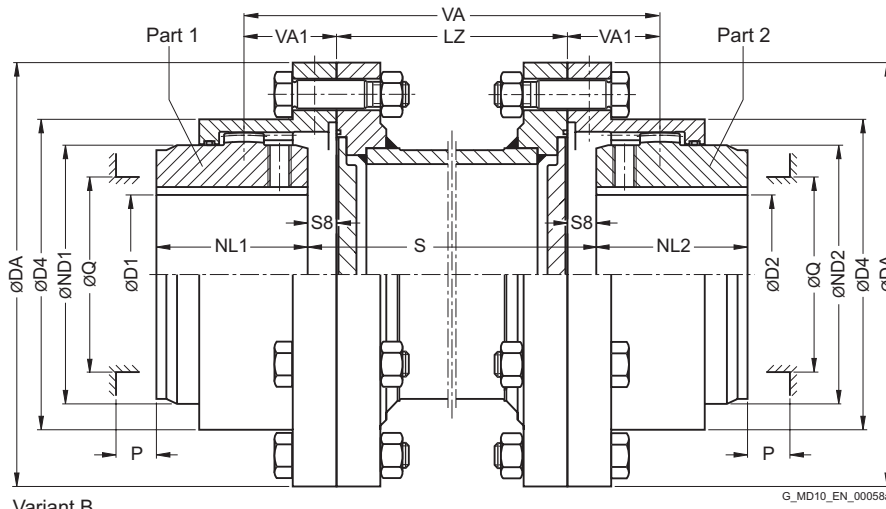

Size	Rated torque $T_{KN}$ Nm	Dimensions in mm												Article no. <sup>1)</sup>		Weight each 100 mm pipe	
		D1, D2 Keyway DIN 6885-1 min. max.		DA	ND1/ND2	NL1/NL2	D4	S8	S9	VA1	Q	P	LZ min.	Type A	Type B	kg	m
83	1020	0	50	117	67	43	83	10.5	1.5	27.5	52	31	75	2LC0330-0AD	2LC0330-0AE	0.9	5.5
107	2210	0	65	152	87	50	107	7.5	1.5	29.5	68	34	85	2LC0330-1AD	2LC0330-1AE	0.8	12
130	4020	0	82	178	108	62	129.5	15.5	1.5	39.5	85	42	95	2LC0330-2AD	2LC0330-2AE	1.2	16
156	6600	0	100	213	130	76	156	14.5	2.5	46.5	110	47	110	2LC0330-3AD	2LC0330-3AE	2.3	28
181	11000	0	116	240	153	90	181	16.5	2.5	54.5	130	58	110	2LC0330-4AD	2LC0330-4AE	3.5	40
211	19200	0	137	280	180	105	211	20	3	64	150	67	125	2LC0330-5AD	2LC0330-5AE	4.5	64
250	30680	0	164	318	214	120	249.5	21	3	72	175	72	125	2LC0330-6AD	2LC0330-6AE	6.3	91
274	43550	80	178	347	233	135	274	25	4	82	190	81	125	2LC0330-7AD	2LC0330-7AE	7.2	115
307	61750	90	198	390	260	150	307	28	4	91	220	91	145	2LC0330-8AD	2LC0330-8AE	9.1	175
333	87100	100	216	425.5	283	175	332.5	35	4	107	250	104	145	2LC0331-0AD	2LC0331-0AE	12	220
364	117000	120	242	457	312	190	364	42	4	118	265	126	145	2LC0331-1AD	2LC0331-1AE	15	245
424	162500	150	288	527	371	220	423.5	38	5	131.5	300	140	145	2LC0331-2AD	2LC0331-2AE	16	360

### Configurable variants <sup>1)</sup>

- ØD1 Without finished bore  
With finished bore
- ØD2 Without finished bore  
With finished bore

### Notes

- $VA = 2 \cdot VA1 + LZ$
- Mass moment of inertia on request.
- Weights apply to the entire coupling with maximum bores and an adapter length of LZ min.
- Maximum speed, limited by weight and critical adapter speed, on request.
- Q Diameter required for renewing the sealing rings.  
P Length required for renewing the sealing rings, aligning the coupling parts and tightening the set screw.

### Ordering example

- ZAPEX ZNZZ coupling, size 107, variant B, adapter for S = 250 mm
- Part 1: Bore 40H7mm, keyway to DIN 6885-1 P9 and set screw
- Part 2: Bore 45K7 mm, keyway to DIN 6885-1 P9 and set screw

Article no.: 2LC0330-1AE99-0AZ0-Z L0W+M1A+Q0Y+M13  
Plain text to Q0Y: 250 mm (dimension S)

<sup>1)</sup> To identify complete item numbers specifying the available finish boring options and – if necessary – further order options, please use our configurators on [flender.com](http://flender.com).

➤ For online configuration on [flender.com](http://flender.com), click on the item no.

# TYPE ZNW

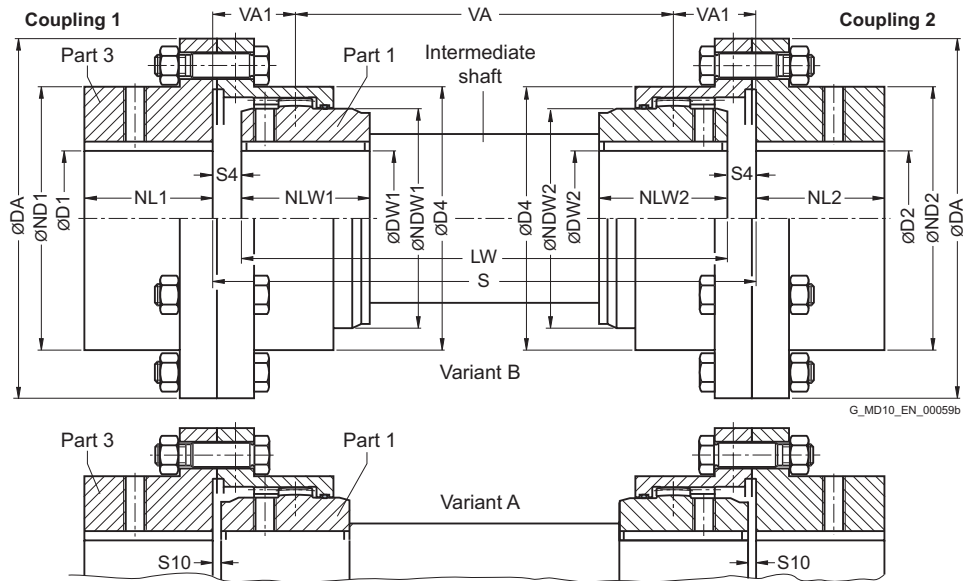

Size	Rated torque $T_{KN}$ Nm	Dimensions in mm											Article no. <sup>1)</sup>		Weight $m$ kg	
		D1, D2 Keyway DIN 6885-1		DA	ND1/ ND2	NL1/NL2/ NLW1/LW2	DW1, DW2 Keyway DIN 6885-1		NDW1/ NDW2	D4	S4	S10	VA1	Type		
		min.	max.				min.	max.						A	B	
83	1020	0	61	117	83	43	0	50	67	83	12	3	29	2LC0330-0AV	2LC0330-0AW	3.1
107	2210	0	79	152	107	50	0	65	87	107	9	3	31	2LC0330-1AV	2LC0330-1AW	6.2
130	4020	0	96	178	129.5	62	0	82	108	129.5	17	3	41	2LC0330-2AV	2LC0330-2AW	9.5
156	6600	0	116	213	156	76	0	100	130	156	17	5	49	2LC0330-3AV	2LC0330-3AW	17
181	11000	0	134	240	181	90	0	116	153	181	19	5	57	2LC0330-4AV	2LC0330-4AW	24.5
211	19200	0	156	280	211	105	0	137	180	211	23	6	67	2LC0330-5AV	2LC0330-5AW	41
250	30680	0	184	318	249.5	120	0	164	214	249.5	24	6	75	2LC0330-6AV	2LC0330-6AW	58
274	43550	80	202	347	274	135	80	178	233	274	29	8	86	2LC0330-7AV	2LC0330-7AW	76
307	61750	90	228	390	307	150	90	198	260	307	32	8	95	2LC0330-8AV	2LC0330-8AW	110
333	87100	100	247	425.5	332.5	175	100	216	283	332.5	39	8	111	2LC0331-0AV	2LC0331-0AW	150
364	117000	120	270	457	364	190	120	242	312	364	46	8	122	2LC0331-1AV	2LC0331-1AW	170
424	162500	150	313	527	423.5	220	150	288	371	423.5	43	10	136.5	2LC0331-2AV	2LC0331-2AW	270

### Configurable variants <sup>1)</sup>

- ØD1 Without finished bore  
With finished bore
- ØD2 Without finished bore  
With finished bore

<sup>1)</sup> To identify complete item numbers specifying the available finish boring options and – if necessary – further order options, please use our configurators on [flender.com](http://flender.com).

↗ For online configuration on [flender.com](http://flender.com), click on the item no.



## Notes

---

- $VA = S - 2 \cdot VA1$
  - Mass moment of inertia on request.
  - Weights apply to either coupling 1 or 2 with maximum bores, without intermediate shaft.
  - Maximum speed, limited by weight and critical speed of intermediate shaft, on request.
- 

## Ordering example

---

- Coupling 1:  
ZAPEX ZNW coupling, size 107, variant B,  
Part 3: Bore 45K7 mm, keyway to DIN 6885-1 P9  
and set screw, Part 1: Bore 45H7 mm,  
keyway to DIN 6885-1 P9 and set screw.
- 

**Article no.:** 2LC0330-1AW99-0AA0-Z L1A+L13+M1A

---

- Intermediate shaft:  
Intermediate shaft to ZAPEX ZNW coupling, size 107,  
length LW = 570 mm, shaft journal  $\varnothing 45p6$  x 50 long;  
keyway DIN 6885-1.
- 

**Article no.:** 2LC9310-0XH00-0AA0-Z Y99

**Plain text to Y99:** DW1 = 45p6 mm, NLW1 = 50 mm,  
DW2 = 45p6 mm, NLW2 = 50 mm, LW = 570 mm

---

- Coupling 2:  
ZAPEX ZNW coupling, size 107, variant B,  
Part 1: Bore 45H7 mm, keyway to DIN 6885-1 P9  
and set screw, Part 3: Bore 45K7 mm,  
keyway to DIN 6885-1 P9 and set screw.
- 

**Article no.:** 2LC0330-0AW99-0AA0-Z L1A+M1A+L13

---

# TYPE ZNBG

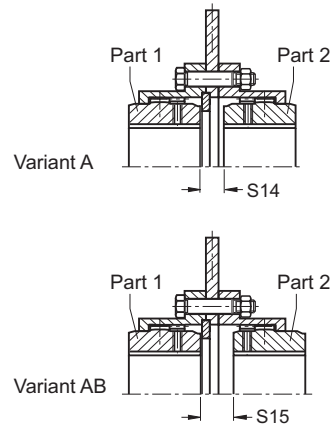
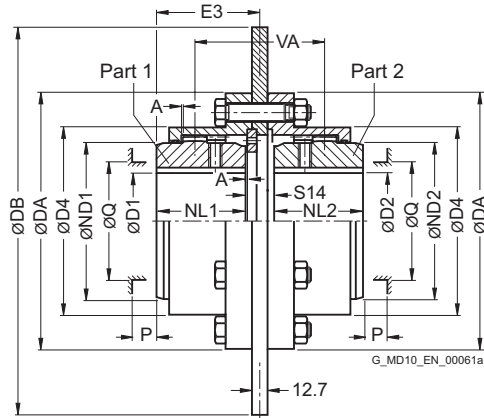

5

Size	Rated torque $T_{KN}$ Nm	Maximum speed $n_{Kmax}$ rpm	Dimensions in mm											Brake disk		Article no. <sup>1)</sup>		Weight $m$ kg	
			D1, D2 Keyway DIN 6885-1 min. max.		DA	ND1/ND2	NL1/NL2	D4	S14	S15	A	VA	Q	P	DB	E3	Type		A
83	1020	3800	0	50	117	67	43	83	17	26	0.5	69	52	31	300	52	2LC0330-0AQ	2LC0330-0AR	10
107	2210	3200	0	65	152	87	50	107	20.5	26.5	0.5	76.5	68	34	356	61	2LC0330-1AQ	2LC0330-1AR	16
130	4020	3200	0	82	178	108	62	129.5	20.5	34.5	0.5	96.5	85	42	356	73	2LC0330-2AQ	2LC0330-2AR	16.5
		17.5							31.5	93.5		406			71.5	2LC0330-2AQ	2LC0330-2AR	19.5	
156	6600	2800	0	100	213	130	76	156	20	32	0.5	108	110	47	406	87	2LC0330-3AQ	2LC0330-3AR	29
		23							35	111		457			88.5	2LC0330-3AQ	2LC0330-3AR	33	
181	11000	2800	0	116	240	153	90	181	20	34	0.5	124	130	58	406	101	2LC0330-4AQ	2LC0330-4AR	38
		23							37	127		457			102.5	2LC0330-4AQ	2LC0330-4AR	42	
211	19200	2500	0	137	280	180	105	211	24.5	41.5	0.5	146.5	150	67	514	102.5	2LC0330-4AQ	2LC0330-4AR	46
		23							37	127		457			118.5	2LC0330-5AQ	2LC0330-5AR	58	
250	30680	2200	0	164	318	214	120	249.5	24.5	41.5	1	162	175	72	514	118.5	2LC0330-5AQ	2LC0330-5AR	71
		24							42	162		610			118.5	2LC0330-5AQ	2LC0330-5AR	77	
		1850	0						24	42	1	162	175	72	610	133	2LC0330-6AQ	2LC0330-6AR	87
		1600							27	45		165			711	134.5	2LC0330-6AQ	2LC0330-6AR	97

### Configurable variants <sup>1)</sup>

- ØD1 Without finished bore  
With finished bore
- ØD2 Without finished bore  
With finished bore

<sup>1)</sup> To identify complete item numbers specifying the available finish boring options and – if necessary – further order options, please use our configurators on [flender.com](http://flender.com).

↗ For online configuration on [flender.com](http://flender.com), click on the item no.

Size	Rated torque $T_{KN}$ Nm	Maximum speed $n_{Kmax}$ rpm	Dimensions in mm													Brake disk		Article no. <sup>1)</sup>		Weight $m$ kg
			D1, D2 Keyway DIN 6885-1		DA	ND1/ND2	NL1/NL2	D4	S14	S15	A	VA	Q	P	DB	E3	Type			
			min.	max.													A	AB		
274	43550	2200	178	347	233	135	274	26.5	47.5	1	182.5	190	81	514	149.5	2LC0330-7AQ	2LC0330-7AR	97		
		1850						26.5	47.5		182.5			610	149.5	2LC0330-7AQ	2LC0330-7AR	105		
		1600						29.5	50.5		185.5			711	151	2LC0330-7AQ	2LC0330-7AR	115		
		1400						35.5	56.5		191.5			812	154	2LC0330-7AQ	2LC0330-7AR	130		
307	61750	1850	198	390	260	150	307	27	51	1	201	220	91	610	165	2LC0330-8AQ	2LC0330-8AR	140		
		1600						30	54		204			711	166.5	2LC0330-8AQ	2LC0330-8AR	155		
		1400						36	60		210			812	169.5	2LC0330-8AQ	2LC0330-8AR	170		
333	87100	1600	216	425.5	283	175	332.5	30	61	1	236	250	104	711	191.5	2LC0331-0AQ	2LC0331-0AR	190		
		1400						36	67		242			812	194.5	2LC0331-0AQ	2LC0331-0AR	205		
364	117000	1400	120	242	457	312	190	364	36	74	1	264	265	126	812	209.5	2LC0331-1AQ	2LC0331-1AR	235	

Configurable variants <sup>1)</sup>

- ØD1 Without finished bore  
With finished bore
- ØD2 Without finished bore  
With finished bore

Notes

- Mass moment of inertia on request.
- Weights apply to maximum bores.
- Variant limited in displacement and axial movement. Max. displacement 0.2°.
- Q Diameter required for renewing the sealing rings.  
P Length required for renewing the sealing rings, aligning the coupling parts and tightening the set screw.

Ordering example

- ZAPEX ZN BG coupling, size 107, variant A, brake disk diameter DB = 356 mm
- Part 1: Bore 40H7mm, keyway to DIN 6885-1 P9 and set screw
- Part 2: Bore 45K7 mm, keyway to DIN 6885-1 P9 and set screw

Article no.: 2LC0330-1AQ99-0AA0-Z L0W+M1A+M13

<sup>1)</sup> To identify complete item numbers specifying the available finish boring options and – if necessary – further order options, please use our configurators on [flender.com](http://flender.com).

↗ For online configuration on [flender.com](http://flender.com), click on the item no.

# TYPE ZNNA

5

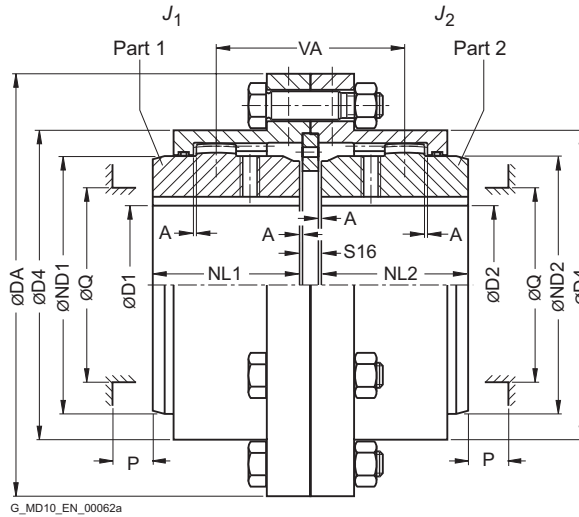

Size	Rated torque $T_{KN}$ Nm	Maximum speed $n_{Kmax}$ rpm	Dimensions in mm											Mass moment of inertia $J_1/J_2$ kgm <sup>2</sup>	Article no. <sup>1)</sup>	Weight $m$ kg	
			D1, D2 Keyway DIN 6885-1		DA	ND1/ND2	NL1/NL2	D4	S16	A	VA	Q	P				
			min.	max.													
83	1020	8500	0	50	117	67	43	83	5	0.5	57	52	31	0.003	2LC0330-0AF	3.3	
107	2210	7700	0	65	152	87	50	107	6	0.5	62	68	34	0.01	2LC0330-1AF	6.7	
130	4020	6900	0	82	178	108	62	129.5	6	0.5	82	85	42	0.021	2LC0330-2AF	10.5	
156	6600	6200	0	100	213	130	76	156	9	0.5	97	110	47	0.05	2LC0330-3AF	18	
181	11000	5800	0	116	240	153	90	181	9	0.5	113	130	58	0.095	2LC0330-4AF	26.5	
211	19200	5100	0	137	280	180	105	211	11	0.5	133	150	67	0.22	2LC0330-5AF	44	
250	30680	4500	0	164	318	214	120	249.5	10	1	148	175	72	0.4	2LC0330-6AF	62	
274	43550	4000	80	178	347	233	135	274	13	1	169	190	81	0.64	2LC0330-7AF	82	
307	61750	3750	90	198	390	260	150	307	14	1	188	220	91	1.1	2LC0330-8AF	115	
333	87100	3550	100	216	425.5	283	175	332.5	14	1	220	250	104	1.8	2LC0331-0AF	155	
364	117000	3400	120	242	457	312	190	364	14	1	242	265	126	2.4	2LC0331-1AF	185	
424	162500	3200	150	288	527	371	220	423.5	18	1	271	300	140	4.9	2LC0331-2AF	285	

### Configurable variants <sup>1)</sup>

- ØD1 Without finished bore  
With finished bore
- ØD2 Without finished bore  
With finished bore

### Ordering example

- ZAPEX ZNNA coupling, size 107
- Part 1: Bore 40H7mm, keyway to DIN 6885-1 P9 and set screw
- Part 2: Bore 45K7 mm, keyway to DIN 6885-1 P9 and set screw

Article no.: 2LC0330-1AF99-0AA0-Z L0W+M1A+M13

### Notes

- Mass moments of inertia apply to a coupling half with maximum bore diameter.
- Weights apply to the entire coupling with maximum bores.
- Variant limited in displacement and axial movement. Max. displacement 0.2°.
- Q Diameter required for renewing the sealing rings.  
P Length required for renewing the sealing rings, aligning the coupling parts and tightening the set screw.

<sup>1)</sup> To identify complete item numbers specifying the available finish boring options and – if necessary – further order options, please use our configurators on [flender.com](http://flender.com).

↗ For online configuration on [flender.com](http://flender.com), click on the item no.

# TYPE ZNZA

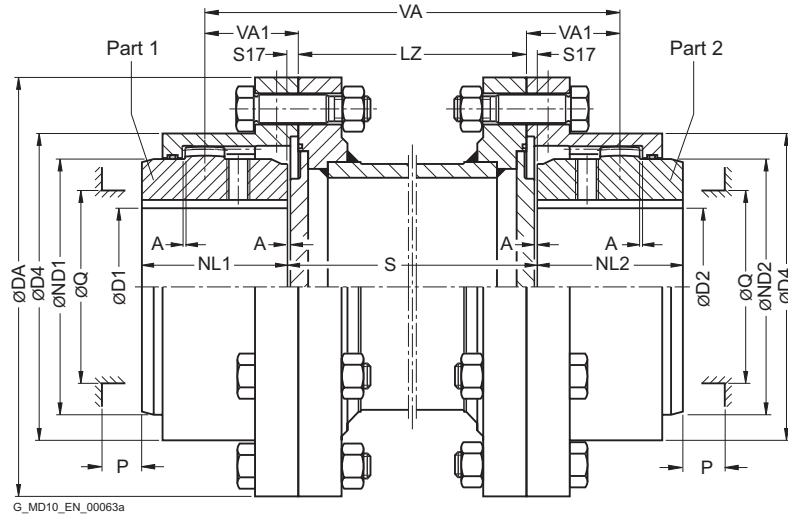

Size	Rated torque $T_{KN}$ Nm	Dimensions in mm											Article no. <sup>1)</sup>	Weight each 100 mm pipe		
		D1, D2 Keyway DIN 6885-1		DA	ND1/ND2	NL1/NL2	D4	S17	A	VA1	Q	P		LZ	m	m
		min.	max.										min.		kg	kg
83	1020	0	50	117	67	43	83	2.5	0.5	28.5	52	31	75	2LC0330-0AG	0.9	5.5
107	2210	0	65	152	87	50	107	3	0.5	31	68	34	85	2LC0330-1AG	0.8	12
130	4020	0	82	178	108	62	129.5	3	0.5	41	85	42	95	2LC0330-2AG	1.2	16
156	6600	0	100	213	130	76	156	4.5	0.5	48.5	110	47	110	2LC0330-3AG	2.3	28
181	11000	0	116	240	153	90	181	4.5	0.5	56.5	130	58	110	2LC0330-4AG	3.5	40
211	19200	0	137	280	180	105	211	5.5	0.5	66.5	150	67	125	2LC0330-5AG	4.5	64
250	30680	0	164	318	214	120	249.5	5	1	74	175	72	125	2LC0330-6AG	6.3	91
274	43550	80	178	347	233	135	274	6.5	1	84.5	190	81	125	2LC0330-7AG	7.2	115
307	61750	90	198	390	260	150	307	7	1	94	220	91	145	2LC0330-8AG	9.1	175
333	87100	100	216	425.5	283	175	332.5	7	1	110	250	104	145	2LC0331-0AG	12	220
364	117000	120	242	457	312	190	364	7	1	121	265	126	145	2LC0331-1AG	15	245
424	162500	150	288	527	371	220	423.5	9	1	135.5	300	140	145	2LC0331-2AG	16	360

### Configurable variants<sup>1)</sup>

- ØD1 Without finished bore  
With finished bore
- ØD2 Without finished bore  
With finished bore

### Notes

- $VA = 2 \cdot VA1 + LZ$
- Mass moment of inertia on request.
- Weights apply to the entire coupling with maximum bores and an adapter length of LZ min.
- Maximum speed, limited by weight and critical adapter speed, on request.
- Q Diameter required for renewing the sealing rings.  
P Length required for renewing the sealing rings, aligning the coupling parts and tightening the set screw.

### Ordering example

- ZAPEX ZNZA coupling, size 107, adapter for S = 250 mm
- Part 1: Bore 40H7mm, keyway to DIN 6885-1 P9 and set screw
- Part 2: Bore 45K7 mm, keyway to DIN 6885-1 P9 and set screw

Article no.: 2LC0330-1AG99-0AZ0-Z L0W+M1A+Q0Y+M13  
Plain text to Q0Y: 250 mm (dimension S)

<sup>1)</sup> To identify complete item numbers specifying the available finish boring options and – if necessary – further order options, please use our configurators on [fletcher.com](http://fletcher.com).

➤ For online configuration on [fletcher.com](http://fletcher.com), click on the item no.

# TYPE ZNNV

5

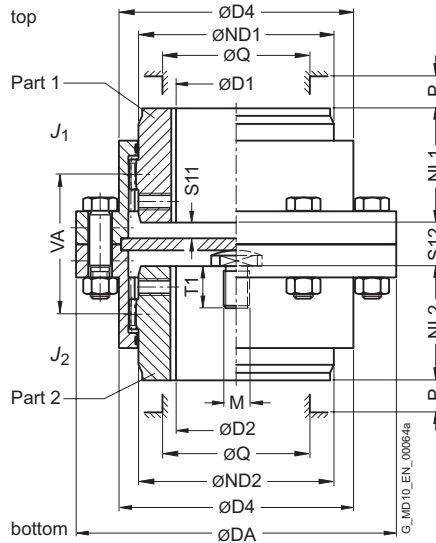

Size	Rated torque $T_{KN}$ Nm	Maximum speed $n_{Kmax}$ rpm	Dimensions in mm											Mass moment of inertia $J_1/J_2$ kgm <sup>2</sup>	Article no. <sup>1)</sup>	Weight $m$ kg	
			D1, D2 Keyway DIN 6885-1		DA	ND1/ND2	NL1/NL2	D4	S11	S12	VA1	Q	P				
			min.	max.													
83	1020	8500	0	50	117	67	43	83	8	21	55	52	31	0.003	2LC0330-0AH	3.5	
107	2210	7700	0	65	152	87	50	107	4.5	15	59	68	34	0.009	2LC0330-1AH	6.6	
130	4020	6900	0	82	178	108	62	129.5	12.5	31	79	85	42	0.023	2LC0330-2AH	10.5	
156	6600	6200	0	100	213	130	76	156	10.5	29	93	110	47	0.055	2LC0330-3AH	17	
181	11000	5800	0	116	240	153	90	181	12.5	33	109	130	58	0.1	2LC0330-4AH	25.5	
211	19200	5100	0	137	280	180	105	211	15	40	128	150	67	0.22	2LC0330-5AH	40	
250	30680	4500	0	164	318	214	120	249.5	17	42	144	175	72	0.37	2LC0330-6AH	54	
274	43550	4000	80	178	347	233	135	274	19.5	50	164	190	81	0.64	2LC0330-7AH	87	
307	61750	3750	90	198	390	260	150	307	22	56	182	220	91	1.2	2LC0330-8AH	130	
333	87100	3550	100	216	425.5	283	175	332.5	29	70	214	250	104	1.8	2LC0331-0AH	160	
364	117000	3400	120	242	457	312	190	364	36	84	236	265	126	2.6	2LC0331-1AH	190	
424	162500	3200	150	288	527	371	220	423.5	30	76	263	300	140	5.4	2LC0331-2AH	270	

### Configurable variants <sup>1)</sup>

- ØD1 Without finished bore  
With finished bore
- ØD2 Without finished bore  
With finished bore

### Notes

- Mass moments of inertia apply to a coupling half with maximum bore diameter.
- Weights apply to the entire coupling with maximum bores.
- When ordering, state thread size M and thread length T1 of the thrust piece.
- Q Diameter required for renewing the sealing rings.  
P Length required for renewing the sealing rings, aligning the coupling parts and tightening the set screw.

### Ordering example

- ZAPEX ZNNV coupling, size 107
- Part 1: Bore 40H7mm, keyway to DIN 6885-1 P9 and set screw
- Part 2: Bore 45K7 mm, keyway to DIN 6885-1 P9 and set screw, thread M10 x 20 deep.

Article no.: 2LC0330-1AH99-0AA0-Z L0W+M1A+M13+Y99  
Plain text to Y99: Thread M10 x 20

<sup>1)</sup> To identify complete item numbers specifying the available finish boring options and – if necessary – further order options, please use our configurators on [flender.com](http://flender.com).

↗ For online configuration on [flender.com](http://flender.com), click on the item no.

# TYPE ZNN FOR AXIAL DISPLACEMENT

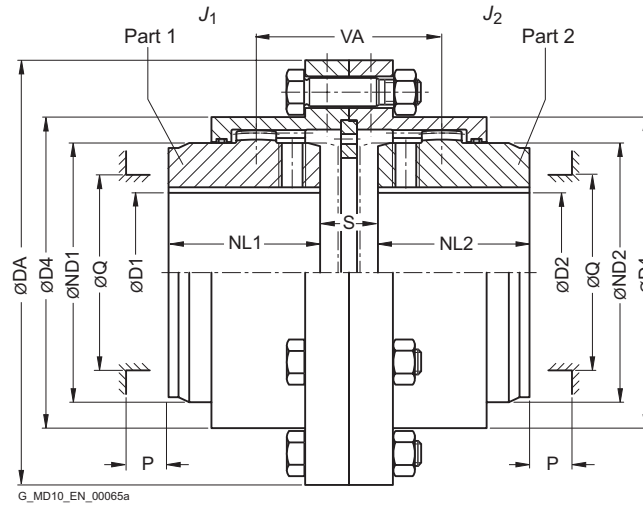

Size	Rated torque $T_{KN}$ Nm	Maximum speed $n_{Kmax}$ rpm	Dimensions in mm											Mass moment of inertia $J_1/J_2$ kgm <sup>2</sup>	Article no. <sup>1)</sup>	Weight $m$ kg
			D1, D2 Keyway DIN 6885-1		DA	ND1/ND2	NL1/NL2	D4	S		VA	Q	P			
			min.	max.					min.	max.						
83	1020	8500	0	50	117	67	43	83	6	21	55	52	31	0.003	2LC0330-0AY	3.3
107	2210	7700	0	65	152	87	50	107	7	15	59	68	34	0.01	2LC0330-1AY	6.7
130	4020	6900	0	82	178	108	62	129.5	16	31	79	85	42	0.021	2LC0330-2AY	10.5
156	6600	6200	0	100	213	130	76	156	11	29	93	110	47	0.05	2LC0330-3AY	18
181	11000	5800	0	116	240	153	90	181	11	33	109	130	58	0.095	2LC0330-4AY	26.5
211	19200	5100	0	137	280	180	105	211	14	40	128	150	67	0.22	2LC0330-5AY	44
250	30680	4500	0	164	318	214	120	249.5	12	42	144	175	72	0.4	2LC0330-6AY	62
274	43550	4000	80	178	347	233	135	274	16	50	164	190	81	0.64	2LC0330-7AY	82
307	61750	3750	90	198	390	260	150	307	17	56	182	220	91	1.1	2LC0330-8AY	115
333	87100	3550	100	216	425.5	283	175	332.5	17	70	214	250	104	1.8	2LC0331-0AY	155
364	117000	3400	120	242	457	312	190	364	17	84	236	265	126	2.4	2LC0331-1AY	185
424	162500	3200	150	288	527	371	220	423.5	23	76	263	300	140	4.9	2LC0331-2AY	285

### Configurable variants <sup>1)</sup>

- ØD1 Without finished bore  
With finished bore
- ØD2 Without finished bore  
With finished bore

### Notes

- VA Valid at S max.
- Mass moments of inertia apply to a coupling half with maximum bore diameter.
- Weights apply to the entire coupling with maximum bores.
- Q Diameter required for renewing the sealing rings.  
P Length required for renewing the sealing rings, aligning the coupling parts and tightening the set screw.

### Ordering example

- ZAPEX ZNN coupling for axial displacement, size 107, S min. = 7 mm, S max. = 15 mm
- Part 1: Bore 40H7mm, keyway to DIN 6885-1 P9 and set screw
- Part 2: Bore 45K7 mm, keyway to DIN 6885-1 P9 and set screw

Article no.: 2LC0330-0AY99-0AA0-Z L0W+M1A+M13

<sup>1)</sup> To identify complete item numbers specifying the available finish boring options and – if necessary – further order options, please use our configurators on [flender.com](http://flender.com).

➤ For online configuration on [flender.com](http://flender.com), click on the item no.

# CUSTOMIZED HUB DESIGN

ZAPEX couplings can be provided with customized S-dimensions and hub lengths.

The entire dimension S results from the sum of the individual measurements SF1 and SF2. SF1 and SF2 are the measurements from the interstice of the coupling ring flange up to the beginning of the respective hub. As standard SF1 and SF2 are identical to each other and the entire S-dimension arises in accordance with them.

SF1 and SF2 can be chosen different on customer request, however the minimal and maximum values of the following table have to be observed. Within these limits the measurements SF1 and SF2 may be chosen freely.

The distance VA of the coupling teeth, the permitted bore diameter and the hub diameter remain unchanged.

By stating the hub S-dimension and both hub lengths the coupling is completely described.

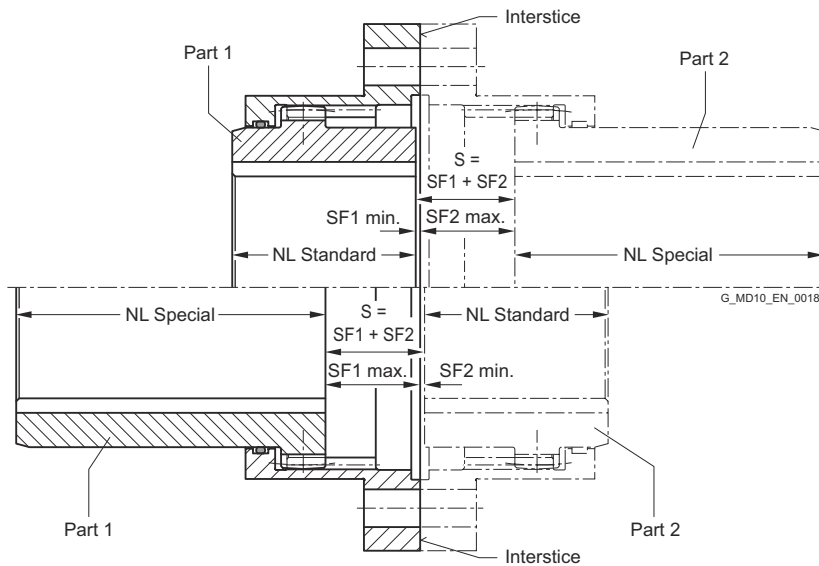

Geometric data			
Size	Standard hub length	Minimal dimension SF1 or SF2 mm	Maximum dimension SF1 or SF2 mm
	NL mm		
83	43	1.5	22
107	50	1.5	23.5
130	62	1.5	32
156	76	2.5	36.5
181	90	2.5	43.5
211	105	3	51
250	120	3	59
274	135	4	64.5
307	150	4	72
333	175	4	85
364	190	4	92
424	220	5	100

The minimal hub lengths are not to fall below the standard hub lengths. If there's no other possibility, for hub lengths smaller than standard hub lengths the order codes "Y50" for part 1 and "Y51" for part 2 must be stated in plain text.

## Article number

The Article number of the respective ZAPEX coupling type must be supplemented with "-Z" and order codes for non standard SF-dimensions (order code "Y38" for part 1 and "Y39" for part 2). For no standard hub lengths the order codes "Y40" to "Y49" must be specified (see Page 5/17).

## Ordering example

- ZAPEX coupling ZNN 130, variant A
- Hub left: Bore D1 = 70H7 mm, keyway to DIN 6885-1 P9 and set screw; NL1 = 110 mm; SF1 = 10 mm
- Hub right: Bore D2 = 75H7 mm, keyway to DIN 6885-1 P9 and set screw; NL2 = 75 mm; SF2 = 25 mm

Article no.: 2LC0330-2AA99-0AA0-Z L1G M1H Y38 Y39 Y41 Y46

Plain text to Y38: SF1 = 10 mm

Plain text to Y39: SF2 = 25 mm

Plain text to Y46: NL1 = 110 mm

Plain text to Y41: NL2 = 75 mm



## Order code for hub prolongations Y4. (Std-NL = Standard hub length)

Part 1		
Selected (special) hub length min.	max.	Order code (specification of hub length in plain text)
>Std-NL	$\leq 1.25 \cdot \text{Std-NL}$	Y40
>1.25 · Std-NL	$\leq 1.5 \cdot \text{Std-NL}$	Y42
>1.5 · Std-NL	$\leq 1.75 \cdot \text{Std-NL}$	Y44
>1.75 · Std-NL	$\leq 2 \cdot \text{Std-NL}$	Y46
>2 · Std-NL		Y48

Part 2		
Selected (special) hub length min.	max.	Order code (specification of hub length in plain text)
>Std-NL	$\leq 1.25 \cdot \text{Std-NL}$	Y41
>1.25 · Std-NL	$\leq 1.5 \cdot \text{Std-NL}$	Y43
>1.5 · Std-NL	$\leq 1.75 \cdot \text{Std-NL}$	Y45
>1.75 · Std-NL	$\leq 2 \cdot \text{Std-NL}$	Y47
>2 · Std-NL		Y49

# TYPE ZN – FLANGE CONNECTION DIMENSIONS

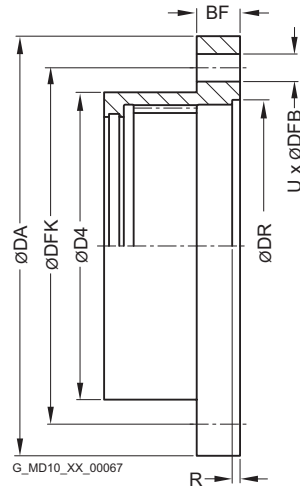

Size	Dimensions in mm							
	DA	BF	D4	DFK	DFB	U Number	DR	R
83	117	14	83	100	9	6	82	2.5
107	152	19	107	131	11	6	105	3
130	178	19	129.5	157	11	8	130	3
156	213	22	156	188	13	6	153	4
181	240	22	181	213	13	10	178	4
211	280	28.5	211	249	17	8	205	5
250	318	28.5	249.5	287	17	10	243	4
274	347	28.5	274	315	17	12	265	5.5
307	390	38	307	352	21	12	302	6
333	425.5	38	332.5	385	21	14	320	6
364	457	26	364	416	21	16	353	6
424	527	28.5	423.5	482	25	16	412	8

# SPARE AND WEAR PARTS

## Sealing rings

The sealing rings are wear parts and must be replaced in accordance with the operating instructions.

Size	Hub diameter ND1/ND2 mm	Article No.
83	67	2LC0330-0XE00-0AA0
107	87	2LC0330-1XE00-0AA0
130	108	2LC0330-2XE00-0AA0
156	130	2LC0330-3XE00-0AA0
181	153	2LC0330-4XE00-0AA0
211	180	2LC0330-5XE00-0AA0
250	214	2LC0330-6XE00-0AA0
274	233	2LC0330-7XE00-0AA0
307	260	2LC0330-8XE00-0AA0
333	283	2LC0331-0XE00-0AA0
364	312	2LC0331-1XE00-0AA0
424	371	2LC0331-2XE00-0AA0

5

## High-performance grease

Container	Content g	Article No.
Cartridge	300	FFA:000000501027

## Sealing compound

Container	Content ml	Article No.
Tube	60	FFA:000001443780



# TORSIONALLY RIGID ALL-STEEL COUPLINGS N-ARPEX AND ARPEX SERIES



<b>Series N-ARPEX ARN-6/-8/-10</b>	<b>6/3</b>
<b>General</b>	<b>6/3</b>
Benefits	6/3
Application	6/4
Design and configurations	6/5
Technical specifications	6/8
Available standard dimensions for the shaft spacing S	6/10
<b>Type NEN/NHN</b>	<b>6/12</b>
<b>TYPE MCECM/MCHCM</b>	<b>6/14</b>
<b>TYPE MFEFM/MFHFM</b>	<b>6/16</b>
<b>TYPE BEB</b>	<b>6/18</b>
<b>Further hubs</b>	<b>6/19</b>
<b>Spare and wear parts</b>	<b>6/22</b>
<b>Length-dependent specifications</b>	<b>6/23</b>
<b>Other design options</b>	<b>6/27</b>

<b>Series ARPEX ARW-4/-6</b>	<b>6/28</b>
<b>General</b>	<b>6/28</b>
Benefits	6/28
Application	6/28
Design and configurations	6/29
Technical specifications	6/30
<b>Type NHN</b>	<b>6/32</b>
<b>Spare and wear parts</b>	<b>6/34</b>

<b>Series ARPEX ARF-6</b>	<b>6/35</b>
<b>General</b>	<b>6/35</b>
Benefits	6/35
Application	6/35
Design and configurations	6/36
Technical specifications	6/37
<b>Types GG and GJ</b>	<b>6/38</b>
<b>Spare and wear parts</b>	<b>6/40</b>



## N-ARPEX

### **FLENDER**



# GENERAL



Coupling suitable for use in potentially explosive atmospheres.

Complies with the current ATEX Directive for:

CE  II 2G Ex h IIC T6 ... T2 Gb X

 II 2D Ex h IIIC T85 °C ... 250 °C Db X

 I M2 Ex h Mb X

## Benefits

N-ARPEX couplings of the ARN-6/-8/-10 series are outstanding for their application-optimized construction. The NEN, BEB, MCECM, MFEFM series meet the requirement of **API 610**. Coupling type in accordance with **API 671** is also possible. For speeds of over 1,800 rpm the five-part version with pre-assembled intermediate unit is used.

A special catching device acts to secure the intermediate spacer in the event of plate breakage. Application of the N-ARPEX couplings in potentially explosive atmospheres in accordance with the current ATEX Directive is permitted.

# GENERAL

## Application

N-ARPEX couplings of the ARN-6/-8/-10 series are used wherever reliable torque transmission is called for, even in cases of often unavoidable shaft misalignment. They are universally applicable over a temperature range of from -50 °C (or even as low as -60 °C on request) up to +280 °C, are torsionally rigid, free of torsional backlash and enable quiet running at a constant angular velocity. They are wear-free and maintenance-free and, if correctly fitted, can be expected to have an unlimited service life.

Especial consideration is given to use in pump and compressor drives. Available for this are couplings with standardised intermediate spacer lengths from stock (see following tables).

By the launch of the new FLENDER N-ARPEX all-steel multiple-disk couplings Flender is continuing the success story of the proven ARPEX coupling series.

An optimised plate pack and a reworked component part design enable even higher torques and speeds to be transmitted.

In short, the new design of the plate packs, the closed flange geometry, the standard catching device of the intermediate spacer and FEM-optimised force distribution inside the all-steel multiple-disk coupling clearly show that the development has paid off.

Main areas of application for the ARN-6/-8/-10 series:

- Pumps
- Fans
- Compressors
- Generator and turbine drives
- Axial and radial blowers
- Paper-making machines and printing machines
- Mixers, Stirrers
- Extruders
- Lifting and traversing gears
- Marine drive
- Water screw drives





## Design and configurations

### NEN

The design of an N-ARPEX type NEN is shown in the following illustration. The coupling comprises two hubs, an intermediate spacer and two plate packs that in the ARN-6 series are bolted together alternately with close-fitting bolts and in the ARN-8/10 series by means of a Flender conical screw connection. The coupling is available in fixed lengths from stock. Other spacer lengths are manufactured to order. Hubs are designed with threaded pull-off holes.

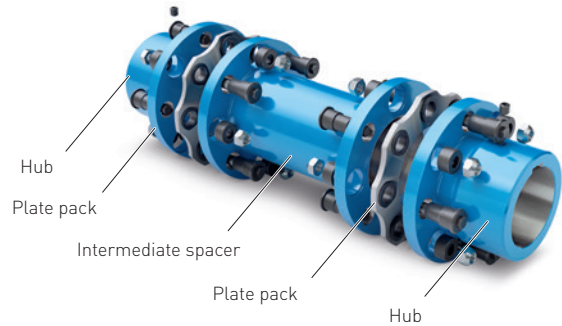

### MCECM

The design of an N-ARPEX type MCECM is shown in the following illustration. The coupling comprises two hubs and a pre-assembled intermediate unit (CEC), where the plate packs are bolted together with an intermediate spacer and intermediate flanges at the factory. All that need be done at the construction site is to bolt the hubs with the intermediate flanges. The coupling is available in fixed lengths from stock. Other spacer lengths are manufactured to order. Hubs are designed with threaded pull-off holes.

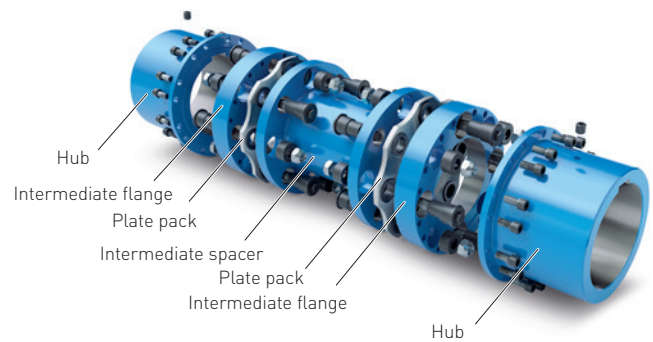

### MFEFM

The following illustration shows the N-ARPEX type MFEFM. It most differs from the type MCECM by the considerably increased bore capacity, for which reason this type is intended precisely for comparatively large shaft diameters. The coupling is available in fixed lengths from stock. Other spacer lengths are manufactured to order. Hubs are designed with threaded pull-off holes.

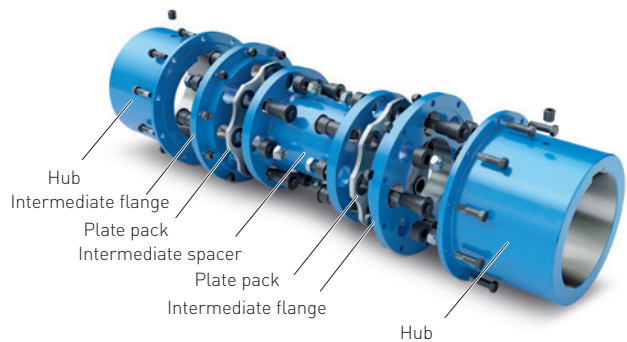

# GENERAL

## Variants of the N-ARPEX coupling, ARN-6/-8/-10 series

Type	Series			Description
	ARN-6	ARN-8	ARN-10	
NEN	■	■	■	Variant with intermediate spacer machined on all sides, length variable
BEB	■	-	-	Variant with intermediate spacer machined on all sides
MCECM	■	■	-	Variant with preassembled intermediate unit and intermediate spacer machined on all sides, length variable
MFEFM	■	■	■	
NHN	■	■	■	Version with variable spacer tube – specially for greater shaft distances (up to 6,500 mm)
MCHCM	■	■	-	Version with pre-assembled intermediate unit and with variable spacer tube – specially for greater shaft distances (up to 6,500 mm)
MFHFM	■	■	■	

The coupling parts of the N-ARPEX ARN-6/-8/-10 series with the exception of the H spacers have been machined on all sides. The H spacers are delivered with unmachined, primed spacer tube.

Dimension sheets and 3D models of the standard types as well as application-related coupling types are available from the DTK selection module at [flender.com](http://flender.com).

### Plate-pack designs

The plate packs of the N-ARPEX ARN series are designed with hexagon, octagon and decagon plates, depending on the coupling size. The number of screw connections is indicated in the denomination of the ARN-6/-8/-10 series. Hexagon plates have 6 bolting points, octagon plates have 8 bolting points and decagon plates have 10 bolting points.

The hexagon plates, octagon plates and decagon plates up to size 631 are designed as ring plates. Sizes 694 to 988 are designed as segmented plates.

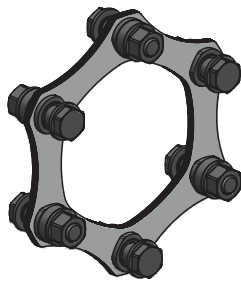

Size 86-6 to 343-6  
(hexagon plates)

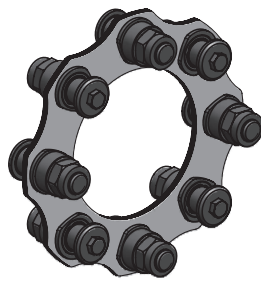

Size 219-8 to 631-8  
(octagon plates)

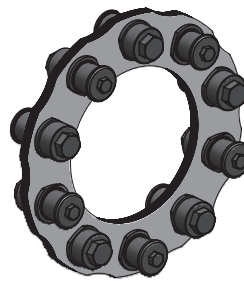

Size 495-10 to 631-10  
(decagon plates)

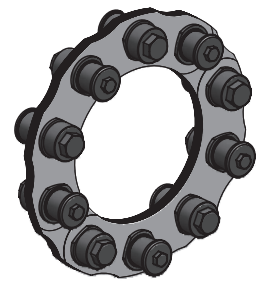

Size 694-10 to 988-10  
(decagon plates/segment)

### Plate pack screw connection

In the ARN-6 series the plate pack screw connection on N-ARPEX couplings is designed in the form of a close-fitting screw connection. In the ARN-8 and ARN-10 series a conical bolt connection by Flender is used.

The advantage of this screw connection is the considerably simplified installation in the case of large screw connections.

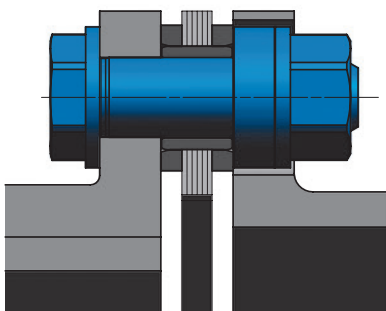

Screw connection / ARN-6 series  
Size 86-6 – 343-6

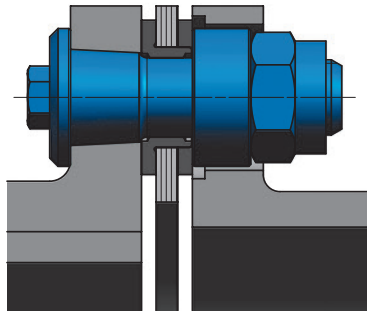

Screw connection / ARN-8 series  
Size 219-8 to 354-8

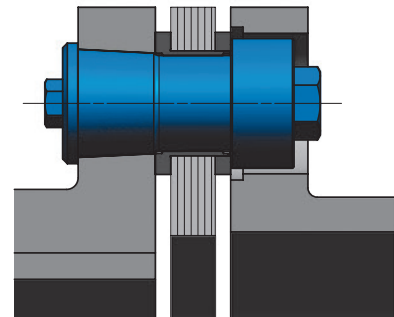

Screw connection / ARN-8 /-10 series  
Size 387-8 to 631-8 / Size 495-10 to 988-10

# GENERAL

## Technical specifications

Power ratings, NEN/NHN, BEB, MCECM/MCHCM and MFEFM/MFHFM series												
Size	Type	Rated torque	Maximum torque	Overload torque	Fatigue torque				Maximum speed	Maximum permitted shaft misalignment (The permissible radial misalignment $\Delta K_r$ depends on the total length of the coupling)		Torsional stiffness for a plate pack $C_{Tdyn}$
					$T_{KN}$	$T_{Kmax}$	$T_{KOL}$	$T_{Kw0}$		$T_{KN} = 0\%T_{KN}$	$T_{Kw} = T_{Kw0} \cdot (1 - T_N/T_{KN})$	
DA		kNm	kNm	kNm	kNm	kNm	kNm	kNm	kNm	rpm	mm	MNm/rad
mm												
86-6	6-Bolt	0.35	0.7	0.875	0.175	0.131	0.088	0.044	24000	1.2	1.0 °	0.132
103-6		0.5	1	1.25	0.25	0.188	0.125	0.063	20000	1.4		0.206
122-6		0.95	1.9	2.375	0.475	0.356	0.238	0.119	17000	2		0.463
133-6		1.25	2.5	3.125	0.625	0.469	0.313	0.156	15000	2.2		0.608
159-6		2.1	4.2	5.25	1.05	0.788	0.525	0.263	13000	2.6		0.986
174-6		2.5	5	6.25	1.25	0.938	0.625	0.313	12000	3		1.19
184-6		3.8	7.6	9.5	1.9	1.425	0.95	0.475	11000	3.2		1.83
203-6		5	10	12.5	2.5	1.875	1.25	0.625	10000	3.4		2.59
217-6		6.2	12.4	15.5	3.1	2.325	1.55	0.775	9500	3.4		3.28
251-6		10.5	21	26.25	5.25	3.938	2.625	1.313	8000	4.1		4.71
268-6		13.8	27.6	34.5	6.9	5.175	3.45	1.725	7500	4.2		5.63
291-6		18.2	36.4	45.5	9.1	6.825	4.55	2.275	7000	4.6		8.27
318-6		23	46	57.5	11.5	8.625	5.75	2.875	6500	5		10.94
343-6		28	56	70	14	10.5	7	3.5	6000	5.3		12.15
219-8		8-Bolt	10	20	25	5	3.75	2.5	1.25	9500		1.7
241-8	15		30	37	7.5	5.625	3.75	1.875	8700	1.9	7.64	
262-8	20		40	50	10	7.5	5	2.5	8000	2.1	9.09	
285-8	27		54	67	13.5	10.125	6.75	3.375	7300	2.2	11.9	
302-8	35		70	87	17.5	13.125	8.75	4.375	6900	2.4	16.2	
321-8	43		86	107	21.5	16.125	10.75	5.375	6500	2.5	21.9	
354-8	56		112	140	28	21	14	7	5900	3	29.1	
387-8	72		144	180	36	27	18	9	5400	3.3	40	
411-8	93		186	232	46.5	34.875	23.25	11.625	5100	3.4	46.9	
447-8	122		244	305	61	45.75	30.5	15.25	4600	2.5	60.3	
495-8	160		320	400	80	60	40	20	4200	3	76.9	
546-8	212		424	530	106	79.5	53	26.5	3800	3.4	100	
587-8	270		540	675	135	101.25	67.5	33.75	3500	3.6	116	
631-8	350		700	875	175	131.25	87.5	43.75	3300	3.8	138	
495-10	10-Bolt		200	350	450	80	60	40	20	4200	2	0.3 °
546-10		270	473	608	108	81	54	27	3800	2.3	194	
587-10		352	616	792	140.8	105.6	70.4	35.2	3500	2.4	236	
631-10		450	788	1013	180	135	90	45	3300	2.5	274	
694-10		630	1103	1418	252	189	126	63	3000	2.7	405	
734-10		760	1330	1710	304	228	152	76	2800	2.8	501	
790-10		950	1663	2138	380	285	190	95	2600	3	632	
887-10		1400	2450	3150	560	420	280	140	2300	3.5	858	
988-10		2000	3500	4500	800	600	400	200	2100	3.9	1163	

### Notes

- The permitted shaft misalignments  $\Delta K_a$ ,  $\Delta K_r$  and  $\Delta K_w$  are maximum values and must not occur at the same time (see table on page 6/9).
- The maximum permissible radial misalignment depends on the shaft distance S. It can be determined for the stated types by using the following formulas:  
 NEN/NHN:  $\Delta K_r = (S - S1) \cdot \tan(\Delta K_w)$   
 BEB, MCECM/ MCHCM and MFEFM/ MFHFM:  $\Delta K_r = (LZ + S1) \cdot \tan(\Delta K_w)$
- $T_{Kmax}$  is permitted five times per hour.
- Length-related values like torsional stiffness, total weight and mass moment of inertia are listed in the tables on pages 6/23 to 6/25.
- The torsional stiffness of the plate packs relates to the nominal range of the coupling. For determination of torsional stiffness for a specific operating point outside the nominal range Flender must be consulted.

**Permitted shaft misalignments, types NEN/NHN, BEB, MCECM/MCHCM and MFEFM/MFHFM**

The permitted shaft misalignments  $\Delta K_a$ ,  $\Delta K_r$  and  $\Delta K_w$  are maximum values and must not occur at the same time. The specified axial misalignments apply to the complete coupling. The permissible angular misalignments have been specified per coupling joint. As all N-ARPEX types are designed to be double-jointed, there is a direct interrelation between radial and angular misalignment.

NEN/NHN:  $\Delta K_r = (S - S1) \cdot \tan(\Delta K_w)$   
 BEB, MCECM/MCHCM and MFEFM/MFHFM:  $\Delta K_r = (LZ + S1) \cdot \tan(\Delta K_w)$

To determine the permissible misalignment, values must, if necessary, be converted.

Size DA	Permitted angular misalignment $\pm \Delta K_w$										
	0.0°	0.1°	0.2°	0.3°	0.4°	0.5°	0.6°	0.7°	0.8°	0.9°	1.0°
	Permitted axial misalignment $\pm \Delta K_a$ in mm										
86-6	1.2	1.1	1	0.8	0.7	0.6	0.5	0.4	0.2	0.1	0
103-6	1.4	1.3	1.1	1	0.8	0.7	0.6	0.4	0.3	0.1	0
122-6	2	1.8	1.6	1.4	1.2	1	0.8	0.6	0.4	0.2	0
133-6	2.2	2	1.8	1.5	1.3	1.1	0.9	0.7	0.4	0.2	0
159-6	2.6	2.3	2.1	1.8	1.6	1.3	1	0.8	0.5	0.3	0
174-6	3	2.7	2.4	2.1	1.8	1.5	1.2	0.9	0.6	0.3	0
184-6	3.2	2.9	2.6	2.2	1.9	1.6	1.3	1	0.6	0.3	0
203-6	3.4	3.1	2.7	2.4	2	1.7	1.4	1	0.7	0.3	0
217-6	3.4	3.1	2.7	2.4	2	1.7	1.4	1	0.7	0.3	0
251-6	4.1	3.7	3.3	2.9	2.5	2.1	1.6	1.2	0.8	0.4	0
268-6	4.2	3.8	3.4	2.9	2.5	2.1	1.7	1.3	0.8	0.4	0
291-6	4.6	4.1	3.7	3.2	2.8	2.3	1.8	1.4	0.9	0.5	0
318-6	5	4.5	4	3.5	3	2.5	2	1.5	1	0.5	0
343-6	5.3	4.8	4.2	3.7	3.2	2.7	2.1	1.6	1.1	0.5	0
219-8	1.7	1.28	0.85	0.43	0	-	-	-	-	-	-
241-8	1.9	1.43	0.95	0.48	0	-	-	-	-	-	-
262-8	2.1	1.58	1.05	0.53	0	-	-	-	-	-	-
285-8	2.2	1.65	1.1	0.55	0	-	-	-	-	-	-
302-8	2.4	1.8	1.2	0.6	0	-	-	-	-	-	-
321-8	2.5	1.88	1.25	0.63	0	-	-	-	-	-	-
354-8	3	2.25	1.5	0.75	0	-	-	-	-	-	-
387-8	3.3	2.48	1.65	0.83	0	-	-	-	-	-	-
411-8	3.4	2.55	1.7	0.85	0	-	-	-	-	-	-
447-8	2.5	1.88	1.25	0.63	0	-	-	-	-	-	-
495-8	3	2.25	1.5	0.75	0	-	-	-	-	-	-
546-8	3.4	2.55	1.7	0.85	0	-	-	-	-	-	-
587-8	3.6	2.7	1.8	0.9	0	-	-	-	-	-	-
631-8	3.8	2.85	1.9	0.95	0	-	-	-	-	-	-
495-10	2	1.33	0.67	0	-	-	-	-	-	-	-
546-10	2.3	1.53	0.77	0	-	-	-	-	-	-	-
587-10	2.4	1.6	0.8	0	-	-	-	-	-	-	-
631-10	2.5	1.67	0.83	0	-	-	-	-	-	-	-
694-10	2.7	1.35	0	-	-	-	-	-	-	-	-
734-10	2.8	1.4	0	-	-	-	-	-	-	-	-
790-10	3	1.5	0	-	-	-	-	-	-	-	-
887-10	3.5	1.75	0	-	-	-	-	-	-	-	-
988-10	3.9	1.95	0	-	-	-	-	-	-	-	-

# GENERAL

## Available standard dimensions for the shaft spacing S

6

Type NEN/NHN															
Size DA	Shaft distance S		Preferred dimension V NEN												
	NEN min. mm	NHN min. mm		100	140	180	200	250	300	{88.9}	{127}	{177.8}	{228.6}	-	
mm	mm	mm								3.5"	5"	7"	9"	-	
86-6	53	300	100	■											
103-6	54	300	100	■											
122-6	65	300	100	■											
133-6	65	300	100	■											
159-6	80	300	100	■											
174-6	80	300	100	■											
184-6	95	350	140		■										
203-6	100	350	140		■										
217-6	105	350	140		■										
251-6	130	350	180			■									
268-6	140	350	180			■									
291-6	140	350	180			■									
318-6	150	400	200				■								
343-6	150	400	200				■								
219-8	129	350	140		■										
241-8	135	350	140		■										
262-8	145	350	180			■									
285-8	162	350	180			■									
302-8	179	350	180			■									
321-8	196	400	200				■								
354-8	214	400	250					■							
387-8	246	400	250					■							
411-8	256	400	300						■						
447-8	270	400	300						■						
495-8	281	600	300						■						
546-8	299	600	300						■						
587-8	315	600	320											■	
631-8	334	600	340											■	
495-10	281	600	300						■						
546-10	299	600	300						■						
587-10	315	600	320											■	
631-10	334	600	340											■	
694-10	400	600	400											■	
734-10	436	600	440											■	
790-10	466	750	470											■	
887-10	543	750	550											■	
988-10	617	750	620											■	

Type MCECM/MCHCM															
Size DA	Shaft distance S		Preferred dimension V MCECM												
	MCECM min. mm	MCHCM min. mm		100	140	180	200	250	300	{127}	{177.8}	{228.6}	-		
mm	mm	mm								5"	7"	9"	-		
86-6	93	340	140		■										
103-6	94	340	140		■										
122-6	105	340	140		■										
133-6	105	340	140		■										
159-6	120	340	140		■										
174-6	120	340	140		■										
184-6	155	410	200				■								
203-6	160	410	200				■								
217-6	165	410	200				■								
251-6	200	420	250					■							
268-6	210	420	250					■							
291-6	210	420	250					■							
318-6	250	500	300						■						
343-6	250	500	300						■						

■ Preferred dimensions      ■ Available standard dimensions

Type MCECM/MCHCM														
Size DA	Shaft distance S		Preferred dimension V MCECM											
	MCECM min. mm	MCHCM min. mm		100	140	180	200	250	300	(127) 5"	(177.8) 7"	(228.6) 9"	-	
mm	mm	mm												
219-8	207	428	218											
241-8	217	432	222											
262-8	233	438	268											
285-8	260	448	278											
302-8	285	456	286											
321-8	308	512	312											
354-8	330	516	366											
387-8	338	492	342											
411-8	350	494	394											
447-8	372	502	402											
495-8	387	706	406											
546-8	413	714	414											
587-8	435	720	440											
631-8	458	724	464											

Type MFEFM/MFHFM														
Size DA	Shaft distance S		Preferred dimension V MFEFM											
	MFEFM min. mm	MFHFM min. mm		100	140	180	200	250	300	(127) 5"	(177.8) 7"	(228.6) 9"	-	
mm	mm	mm												
86-6	93	340	140	■	■									
103-6	94	340	140	■	■									
122-6	105	340	140	■	■									
133-6	105	340	140	■	■									
159-6	120	340	140	■	■									
174-6	120	340	140	■	■									
184-6	155	410	200				■	■						
203-6	160	410	200				■	■						
217-6	165	410	200				■	■						
251-6	200	420	250					■	■					
268-6	210	420	250					■	■					
291-6	210	470	300						■	■				
318-6	250	500	300						■	■				
343-6	250	500	300						■	■				
219-8	207	428	218											■
241-8	217	432	222											■
262-8	233	438	268											■
285-8	260	448	278											■
302-8	285	456	286											■
321-8	308	512	312											■
354-8	330	516	366											■
387-8	338	492	342											■
411-8	350	494	394											■
447-8	372	502	402											■
495-8	387	706	406											■
546-8	413	714	414											■
587-8	435	720	440											■
631-8	458	724	464											■
495-10	387	706	406											■
546-10	413	714	414											■
587-10	435	720	440											■
631-10	458	724	464											■
694-10	552	752	552											■
734-10	600	764	604											■
790-10	646	930	650											■
887-10	749	956	756											■
988-10	857	900	860											■

■ Preferred dimensions      ■ Available standard dimensions

# TYPE NEN/NHN

Torsionally rigid couplings of type NEN (NHN) with radially freely demountable intermediate spacer and catching device to secure the intermediate spacer in the event of

plate breakage. Standard coupling type in accordance with **API 610**. Coupling type in accordance with **API 671** (up to  $n = 1800$  rpm) possible.

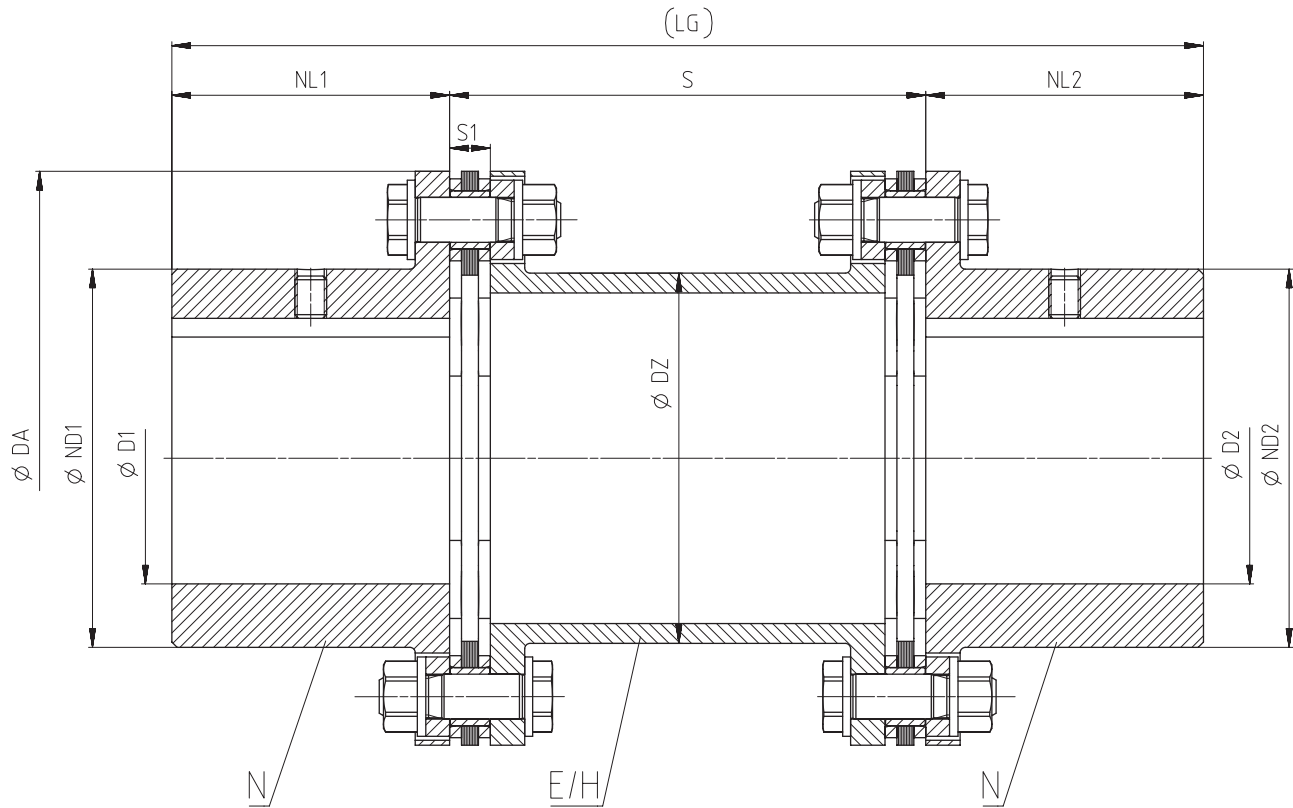

Size DA mm	Rated torque $T_{KN}$ kNm	Maximum speed $n_{Kmax}$ rpm	Dimensions in mm								Article no. <sup>1)</sup>		Weight <i>m</i> kg	
			D1/D2 Keyway DIN 6885-1 max.	ND1/ ND2	NL1/ NL2	DZ	S1	Shaft distance S		Preferred dimension V	LG	Intermediate spacer		
								NEN min.	NHN min.	NEN		E spacer (NEN)	H spacer (NHN)	
86-6	0.35	24000	42	56	45	45	8	53	300	100	190	2LC0370-0AA	2LC0370-0AL	1.9
103-6	0.5	20000	55	73	55	60	8.4	54	300	100	210	2LC0370-1AA	2LC0370-1AL	3
122-6	0.95	17000	65	85	65	73	8.8	65	300	100	230	2LC0370-2AA	2LC0370-2AL	5.1
133-6	1.25	15000	75	96	75	85	9.6	65	300	100	250	2LC0370-3AA	2LC0370-3AL	6.4
159-6	2.1	13000	80	104	80	97	11.6	80	300	100	260	2LC0370-4AA	2LC0370-4AL	9.6
174-6	2.5	12000	90	118	85	116	12.8	80	300	100	270	2LC0370-5AA	2LC0370-5AL	11.8
184-6	3.8	11000	95	124	90	123	14.6	95	350	140	320	2LC0370-6AA	2LC0370-6AL	16.4
203-6	5	10000	100	135	95	128	15	100	350	140	330	2LC0370-7AA	2LC0370-7AL	21.3
217-6	6.2	9500	110	143	105	140	15.4	105	350	140	350	2LC0370-8AA	2LC0370-8AL	24.4
251-6	10.5	8000	120	160	110	160	20.6	130	350	180	400	2LC0371-0AA	2LC0371-0AL	38
268-6	13.8	7500	130	170	130	166	22	140	350	180	440	2LC0371-1AA	2LC0371-1AL	48.6
291-6	18.2	7000	145	190	140	188	22.8	140	350	180	460	2LC0371-2AA	2LC0371-2AL	62.8
318-6	23	6500	155	205	150	197	23.2	150	400	200	500	2LC0371-3AA	2LC0371-3AL	83.9
343-6	28	6000	170	230	160	223	24	150	400	200	520	2LC0371-4AA	2LC0371-4AL	104

<sup>1)</sup> To identify complete item numbers specifying the available finish boring options and – if necessary – further order options, please use our configurators on [flender.com](http://flender.com).

<sup>2)</sup> The S shaft spacing standard dimensions available for each size can be found on [Page 6/10](http://Page 6/10).

➤ For online configuration on [flender.com](http://flender.com), click on the item no.



Size DA mm	Rated torque $T_{KN}$ kNm	Maximum speed $n_{Kmax}$ rpm	Dimensions in mm										Article no. <sup>1)</sup>		Weight <i>m</i> kg
			D1/D2 Keyway DIN 6885-1 max.	ND1/ ND2	NL1/ NL2	DZ	S1	Shaft distance S		Preferred dimension V NEN	LG	Intermediate spacer			
								NEN min.	NHN min.			E spacer (NEN)	H spacer (NHN)		
219-8	10	9500	100	137	115	124	12.2	129	350	140	370	2LC0380-0AA	2LC0380-0AL	31.9	
241-8	15	8700	110	150	127	135	12.6	135	350	140	394	2LC0380-1AA	2LC0380-1AL	41.3	
262-8	20	8000	120	163	138	148	13.8	145	350	180	456	2LC0380-2AA	2LC0380-2AL	53.8	
285-8	27	7300	130	177	150	162	15.2	162	350	180	480	2LC0380-3AA	2LC0380-3AL	70.8	
302-8	35	6900	140	192	161	174	17.2	179	350	180	502	2LC0380-4AA	2LC0380-4AL	89.4	
321-8	43	6500	150	206	173	189	21	196	400	200	546	2LC0380-5AA	2LC0380-5AL	109	
354-8	56	5900	170	232	196	216	23.6	214	400	250	642	2LC0380-6AA	2LC0380-6AL	149	
387-8	72	5400	190	258	219	240	26	246	400	250	688	2LC0380-7AA	2LC0380-7AL	193	
411-8	93	5100	200	272	230	250	29.6	256	400	300	760	2LC0380-8AA	2LC0380-8AL	236	
447-8	122	4600	220	299	253	275	32.6	270	400	300	806	2LC0381-0AA	2LC0381-0AL	299	
495-8	160	4200	250	340	288	312	33.8	281	600	300	876	2LC0381-1AA	2LC0381-1AL	402	
546-8	212	3800	280	381	322	351	40	299	600	300	944	2LC0381-2AA	2LC0381-2AL	547	
587-8	270	3500	300	408	345	363	45	315	600	320	1010	2LC0381-3AA	2LC0381-3AL	690	
631-8	350	3300	320	435	368	399	48.8	334	600	340	1076	2LC0381-4AA	2LC0381-4AL	835	
495-10	200	4200	250	340	288	312	33.8	281	600	300	876	2LC0390-0AA	2LC0390-0AL	402	
546-10	270	3800	280	381	322	351	40	299	600	300	944	2LC0390-1AA	2LC0390-1AL	547	
587-10	352	3500	300	408	345	363	45	315	600	320	1010	2LC0390-2AA	2LC0390-2AL	690	
631-10	450	3300	320	435	368	399	48.8	334	600	340	1076	2LC0390-3AA	2LC0390-3AL	834	
694-10	630	3000	350	485	403	435	58	400	600	400	1206	2LC0390-4AA	2LC0390-4AL	1213	
734-10	760	2800	370	512	426	459	63	436	600	440	1292	2LC0390-5AA	2LC0390-5AL	1463	
790-10	950	2600	400	555	460	496	66	466	750	470	1390	2LC0390-6AA	2LC0390-6AL	1837	
887-10	1400	2300	450	627	518	546	78	543	750	550	1586	2LC0390-7AA	2LC0390-7AL	2713	
988-10	2000	2100	500	696	575	596	86	617	750	620	1770	2LC0390-8AA	2LC0390-8AL	3868	

Configurable variants <sup>1)</sup>

- ØD1 Without finished bore  
With finished bore
- ØD2 Without finished bore  
With finished bore
- Shaft distance S <sup>2)</sup> Metric (mm): 100 mm, 140 mm, 180 mm, 200 mm, 250 mm, 300 mm  
Imperial (inches): 3.5" (88.9 mm), 5" (127 mm), 7" (177.8 mm), 9" (228.6 mm)  
Any required (mm)

Notes

- Spacer sleeves (type NEN) designed as electrical cable sleeves are API compliant.
- Hubs are designed with threaded pull-off holes. Special lengths available upon request.
- The total lengths and the weights apply to the whole coupling of type NEN with maximum bores D1/D2 and the preferred shaft distance S = V.
- In cases with large shaft distances S the intermediate spacer can be designed as an H-spacer. The tube diameters here may slightly diverge. More precise coupling data in cases of variable shaft distances and E- / H-spacers are given on pages 6/23 to 6/25.
- E-spacers in preferred lengths up to size 343-6 are available from stock.

Ordering example

- N-ARPEX ARN-6 NEN coupling, size 217-6, with shaft distance S = 140 mm
- Bore ØD1 50H7 mm, keyway to DIN 6885-1 P9 and set screw (L1C)
- Bore ØD2 60H7 mm, keyway to DIN 6885-1 P9 and set screw (M1E)

Article no.: 2LC0370-8AA99-0AB0-Z L1C+M1E

<sup>1)</sup> To identify complete item numbers specifying the available finish boring options and – if necessary – further order options, please use our configurators on [flender.com](http://flender.com).

<sup>2)</sup> The S shaft spacing standard dimensions available for each size can be found on Page 6/10.

➤ For online configuration on [flender.com](http://flender.com), click on the item no.

# TYPE MCECM/MCHCM

Torsionally rigid couplings of type MCECM (MCHCM) with radially freely demountable pre-assembled intermediate unit and catching device to secure the intermediate spacer

in the event of plate breakage. Standard coupling type in accordance with **API 610**. Coupling type in accordance with **API 671** possible.

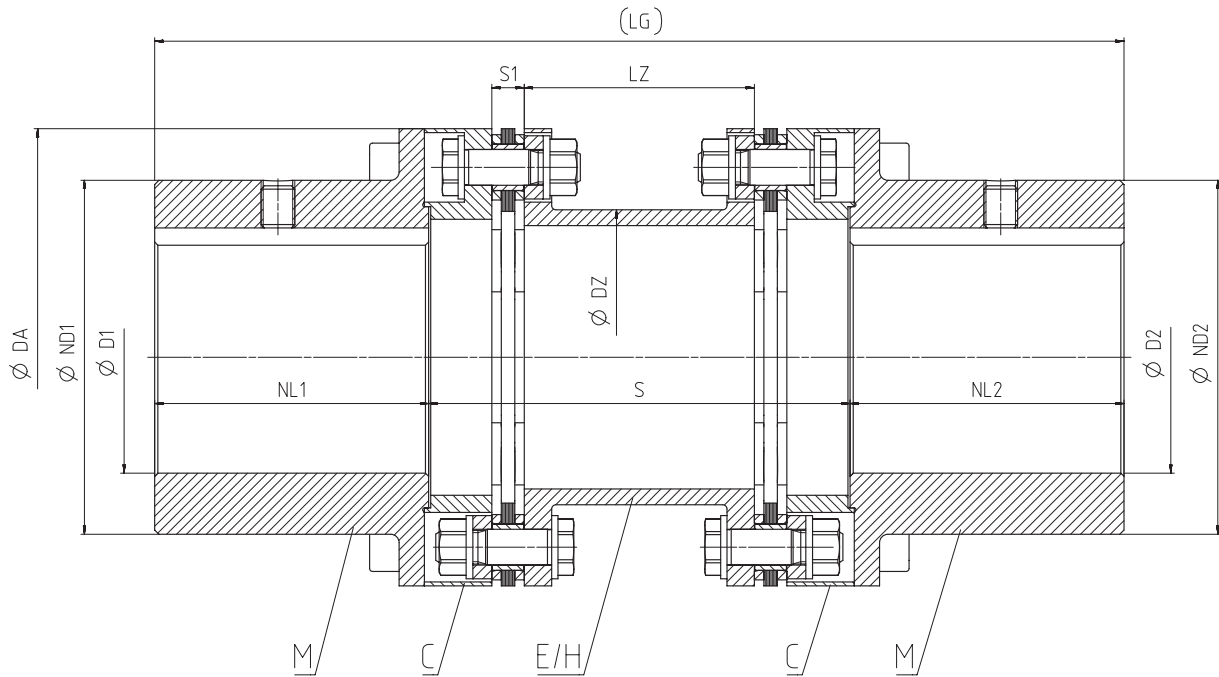

Size DA	Rated torque $T_{KN}$	Maximum speed $n_{Kmax}$	Dimensions in mm										Article no. <sup>1)</sup>		Weight <i>m</i>
			D1/D2 Keyway DIN 6885-1 max.	ND1/ ND2	NL1/ NL2	DZ	LZ	S1	Shaft distance S		Preferred dimension V	LG	Intermediate spacer		
mm	kNm	rpm							MCECM min.	MCHCM min.	MCECM		E spacer (MCECM)	H spacer (MCHCM)	kg
86-6	0.35	24000	42	62	42	45	84	8	93	340	140	224	2LC0370-0AC	2LC0370-0AM	3.1
103-6	0.5	20000	55	72	55	60	83.2	8.4	94	340	140	250	2LC0370-1AC	2LC0370-1AM	4.7
122-6	0.95	17000	70	91	70	73	82.4	8.8	105	340	140	280	2LC0370-2AC	2LC0370-2AM	7.7
133-6	1.25	15000	80	103	80	85	80.8	9.6	105	340	140	300	2LC0370-3AC	2LC0370-3AM	9.6
159-6	2.1	13000	95	123	95	97	76.8	11.6	120	340	140	330	2LC0370-4AC	2LC0370-4AM	15.9
174-6	2.5	12000	105	136	105	116	74.4	12.8	120	340	140	350	2LC0370-5AC	2LC0370-5AM	19.3

### Configurable variants <sup>1)</sup>

- ØD1 Without finished bore  
With finished bore
- ØD2 Without finished bore  
With finished bore
- Shaft distance S <sup>2)</sup> Metric (mm): 100 mm, 140 mm, 180 mm, 200 mm, 250 mm, 300 mm  
Imperial (inches): 5" (127 mm), 7" (177.8 mm), 9" (228.6 mm)  
Any required (mm)

<sup>1)</sup> To identify complete item numbers specifying the available finish boring options and – if necessary – further order options, please use our configurators on [flender.com](http://flender.com).

<sup>2)</sup> The S shaft spacing standard dimensions available for each size can be found on [Page 6/10](http://Page 6/10).

➤ For online configuration on [flender.com](http://flender.com), click on the item no.

Size DA	Rated torque $T_{KN}$	Maximum speed $n_{Kmax}$	Dimensions in mm										Article no. <sup>1)</sup>		Weight <i>m</i>
			D1/D2 Keyway DIN 6885-1 max.	ND1/ ND2	NL1/ NL2	DZ	LZ	S1	Shaft distance S		Preferred dimension V MCECM	LG	Intermediate spacer		
									MCECM min.	MCHCM min.			E spacer (MCECM)	H spacer (MCHCM)	
mm	kNm	rpm												kg	
184-6	3.8	11000	110	142	110	123	110.8	14.6	155	410	200	420	2LC0370-6AC	2LC0370-6AM	26.6
203-6	5	10000	115	150	115	128	110	15	160	410	200	430	2LC0370-7AC	2LC0370-7AM	33.7
217-6	6.2	9500	130	168	130	140	109.2	15.4	165	410	200	460	2LC0370-8AC	2LC0370-8AM	40.3
251-6	10.5	8000	150	193	150	160	138.8	20.6	200	420	250	550	2LC0371-0AC	2LC0371-0AM	64.4
268-6	13.8	7500	160	206	160	166	136	22	210	420	250	570	2LC0371-1AC	2LC0371-1AM	78.8
291-6	18.2	7000	170	221	170	188	134.4	22.8	210	420	250	590	2LC0371-2AC	2LC0371-2AM	98.3
318-6	23	6500	190	245	190	197	153.6	23.2	250	500	300	680	2LC0371-3AC	2LC0371-3AM	139
343-6	28	6000	205	267	205	223	152	24	250	500	300	710	2LC0371-4AC	2LC0371-4AM	168
219-8	10	9500	140	179	140	124	115.6	12.2	207	428	218	498	2LC0380-0AC	2LC0380-0AM	50.3
241-8	15	8700	155	201	155	135	114.8	12.6	217	432	222	532	2LC0380-1AC	2LC0380-1AM	68.2
262-8	20	8000	165	218	165	148	152.4	13.8	233	438	268	598	2LC0380-2AC	2LC0380-2AM	89
285-8	27	7300	185	239	185	162	149.6	15.2	260	448	278	648	2LC0380-3AC	2LC0380-3AM	115
302-8	35	6900	190	250	190	174	145.6	17.2	285	456	286	666	2LC0380-4AC	2LC0380-4AM	140
321-8	43	6500	205	269	205	189	158	21	308	512	312	722	2LC0380-5AC	2LC0380-5AM	171
354-8	56	5900	230	296	230	216	202.8	23.6	330	516	366	826	2LC0380-6AC	2LC0380-6AM	220
387-8	72	5400	255	329	255	240	198	26	338	492	342	852	2LC0380-7AC	2LC0380-7AM	275
411-8	93	5100	270	347	270	250	240.8	29.6	350	494	394	934	2LC0380-8AC	2LC0380-8AM	332
447-8	122	4600	290	375	290	275	234.8	32.6	372	502	402	982	2LC0381-0AC	2LC0381-0AM	419
495-8	160	4200	325	423	325	312	232.4	33.8	387	706	406	1056	2LC0381-1AC	2LC0381-1AM	561
546-8	212	3800	360	468	360	351	220	40	413	714	414	1134	2LC0381-2AC	2LC0381-2AM	752
587-8	270	3500	380	499	380	363	230	45	435	720	440	1200	2LC0381-3AC	2LC0381-3AM	945
631-8	350	3300	410	535	410	399	242.4	48.8	458	724	464	1284	2LC0381-4AC	2LC0381-4AM	1146

Configurable variants <sup>1)</sup>

- ØD1 Without finished bore  
With finished bore
- ØD2 Without finished bore  
With finished bore
- Shaft distance S <sup>2)</sup> Metric (mm): 100 mm, 140 mm, 180 mm, 200 mm, 250 mm, 300 mm  
Imperial (inches): 5" (127 mm), 7" (177.8 mm), 9" (228.6 mm)  
Any required (mm)

Notes

- Spacer sleeves (type MCECM) designed as electrical cable sleeves are API compliant.
- Hubs are designed with threaded pull-off holes. Special lengths available upon request.
- The total lengths, the spacer lengths and the weights apply to the whole coupling of type MCECM with maximum bores D1/D2 and the preferred shaft distance S = V.
- In cases with large shaft distances S the intermediate spacer can be designed as an H-spacer. The tube diameters here may slightly diverge. More precise coupling data in cases of variable shaft distances and E- / H-spacers are given on pages 6/23 to 6/25.
- Plate packs in the CEC/CHC intermediate unit assembled at the factory.
- E-spacers in preferred lengths up to size 343-6 are available from stock.

Ordering example

- N-ARPEX ARN-6 MCECM coupling, size 217-6, with shaft distance S = 200 mm
- Bore ØD1 60H7 mm, keyway to DIN 6885-1 P9 and set screw (L1G)
- Bore ØD2 70H7 mm, keyway to DIN 6885-1 P9 and set screw (M1G)

Article no.: 2LC0370-8AC99-0AD0-Z L1G+M1G

<sup>1)</sup> To identify complete item numbers specifying the available finish boring options and – if necessary – further order options, please use our configurators on [flender.com](http://flender.com).

<sup>2)</sup> The S shaft spacing standard dimensions available for each size can be found on Page 6/10.

➤ For online configuration on [flender.com](http://flender.com), click on the item no.

# TYPE MFEFM/MFHFM

Torsionally rigid type MFEFM (MFHFM) couplings with enlarged bore capacity and radially freely demountable intermediate unit and catching device to secure the inter-

mediate spacer in the event of plate breakage. Standard coupling type in accordance with **API 610**. Coupling type in accordance with **API 671** possible.

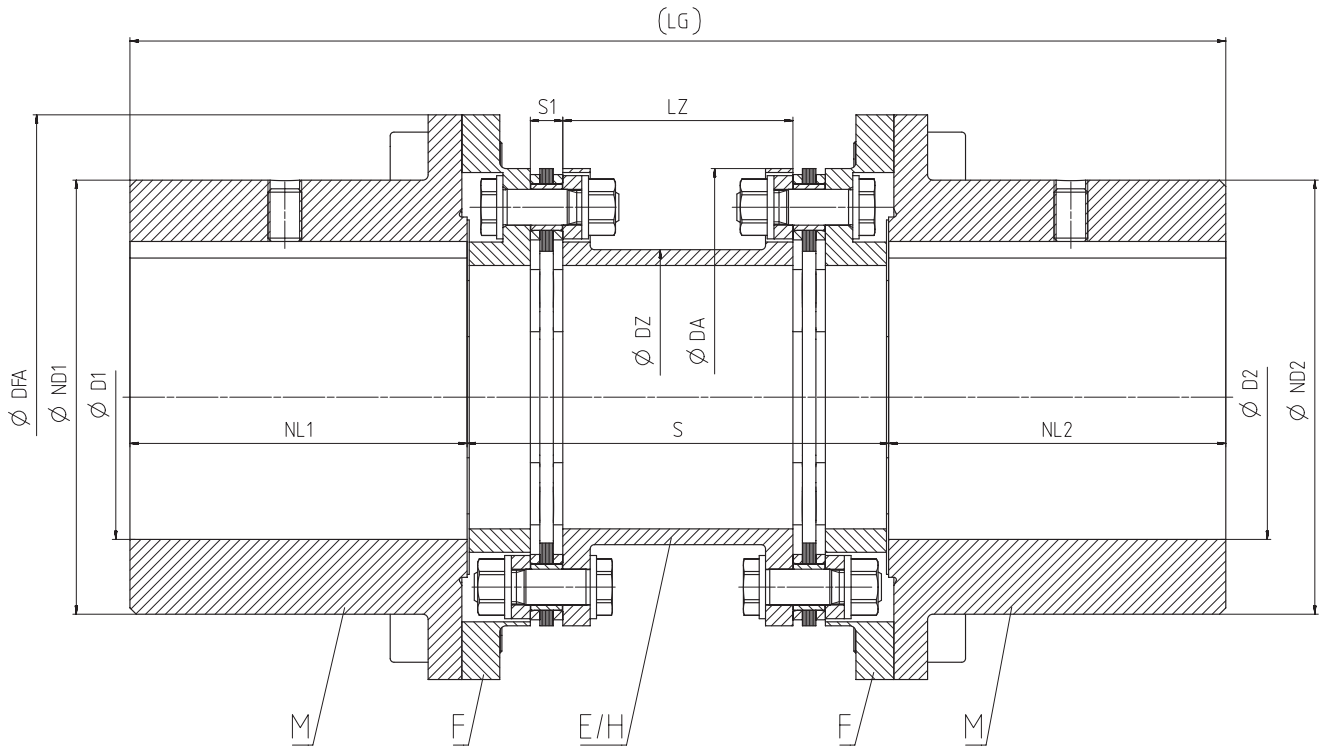

Size	Rated torque $T_{KN}$	Maximum speed $n_{Kmax}$	Dimensions in mm										Article no. <sup>1)</sup>		Weight $m$		
			DFA	D1/D2 Keyway DIN 6885-1 max.	ND1/ ND2	NL1/ NL2	DZ	LZ	S1	Shaft distance S		Preferred dimension V	LG	Intermediate spacer			
mm	kNm	rpm									MFEFM min.	MFHFM min.	MFEFM		E spacer (MFEFM)	H spacer (MFHFM)	kg
86-6	0.35	17000	122	70	91	70	45	84	8	93	340	340	140	280	2LC0370-0BA	2LC0370-0BC	6
103-6	0.5	15000	133	80	103	80	60	83.2	8.4	94	340	340	140	300	2LC0370-1BA	2LC0370-1BC	8
122-6	0.95	13000	159	95	123	95	73	82.4	8.8	105	340	340	140	330	2LC0370-2BA	2LC0370-2BC	13.6
133-6	1.25	12000	174	105	136	105	85	80.8	9.6	105	340	340	140	350	2LC0370-3BA	2LC0370-3BC	17.1
159-6	2.1	10000	203	115	150	115	97	76.8	11.6	120	340	340	140	370	2LC0370-4BA	2LC0370-4BC	22.9
174-6	2.5	9500	217	130	168	130	116	74.4	12.8	120	340	340	140	400	2LC0370-5BA	2LC0370-5BC	26.8
184-6	3.8	8000	251	150	193	150	123	110.8	14.6	155	410	200	500	2LC0370-6BA	2LC0370-6BC	40.1	
203-6	5	8000	251	150	193	150	128	110	15	160	410	200	500	2LC0370-7BA	2LC0370-7BC	52.8	
217-6	6.2	7500	268	160	206	160	140	109.2	15.4	165	410	200	520	2LC0370-8BA	2LC0370-8BC	63.4	
251-6	10.5	6500	318	190	245	190	160	138.8	20.6	200	420	250	630	2LC0371-0BA	2LC0371-0BC	109	

### Configurable variants <sup>1)</sup>

- $\varnothing D1$  Without finished bore  
With finished bore
- $\varnothing D2$  Without finished bore  
With finished bore
- Shaft distance S <sup>2)</sup> Metric (mm): 100 mm, 140 mm, 180 mm, 200 mm, 250 mm, 300 mm  
Imperial (inches): 5" (127 mm), 7" (177.8 mm), 9" (228.6 mm)  
Any required (mm)

<sup>1)</sup> To identify complete item numbers specifying the available finish boring options and – if necessary – further order options, please use our configurators on [flender.com](http://flender.com).

<sup>2)</sup> The S shaft spacing standard dimensions available for each size can be found on [Page 6/10](http://Page 6/10).

➤ For online configuration on [flender.com](http://flender.com), click on the item no.

Size DA	Rated torque $T_{KN}$	Maximum speed $n_{Kmax}$	Dimensions in mm										Article no. <sup>1)</sup>		Weight <i>m</i> kg	
			DFA	D1/D2 Keyway DIN 6885-1 max.	ND1/ ND2	NL1/ NL2	DZ	LZ	S1	Shaft distance S		Preferred dimension V MFEFM	LG	Intermediate spacer		
										MFEFM min.	MFHFM min.			E spacer (MFEFM)		H spacer (MFHFM)
268-6	13.8	6000	343	205	267	205	166	136	22	210	420	250	660	2LC0371-1BA	2LC0371-1BC	136
291-6	18.2	5500	356	230	302	230	188	134.4	22.8	210	470	300	760	2LC0371-2BA	2LC0371-2BC	190
318-6	23	5500	375	245	321	245	197	153.6	23.2	250	500	300	790	2LC0371-3BA	2LC0371-3BC	221
343-6	28	4500	424	270	354	270	223	152	24	250	500	300	840	2LC0371-4BA	2LC0371-4BC	284
219-8	10	7800	267	165	219	165	124	115.6	12.2	207	428	218	548	2LC0380-0BA	2LC0380-0BC	77.7
241-8	15	7200	289	185	241	185	135	114.8	12.6	217	432	222	592	2LC0380-1BA	2LC0380-1BC	98.6
262-8	20	6600	314	200	262	200	148	152.4	13.8	233	438	268	668	2LC0380-2BA	2LC0380-2BC	131
285-8	27	6100	339	215	285	215	162	149.6	15.2	260	448	278	708	2LC0380-3BA	2LC0380-3BC	169
302-8	35	5900	356	230	302	230	174	145.6	17.2	285	456	286	746	2LC0380-4BA	2LC0380-4BC	200
321-8	43	5600	375	245	321	245	189	158	21	308	512	312	802	2LC0380-5BA	2LC0380-5BC	237
354-8	56	4900	424	270	354	270	216	202.8	23.6	330	516	366	906	2LC0380-6BA	2LC0380-6BC	315
387-8	72	4500	457	295	387	295	240	198	26	338	492	342	932	2LC0380-7BA	2LC0380-7BC	384
411-8	93	4300	481	315	411	315	250	240.8	29.6	350	494	394	1024	2LC0380-8BA	2LC0380-8BC	460
447-8	122	4000	519	340	447	340	275	234.8	32.6	372	502	402	1082	2LC0381-0BA	2LC0381-0BC	586
495-8	160	3700	567	380	495	380	312	232.4	33.8	387	706	406	1166	2LC0381-1BA	2LC0381-1BC	758
546-8	212	3300	624	420	546	420	351	220	40	413	714	414	1254	2LC0381-2BA	2LC0381-2BC	1011
587-8	270	3100	669	450	587	450	363	230	45	435	720	440	1340	2LC0381-3BA	2LC0381-3BC	1270
631-8	350	2900	719	480	631	480	399	242.4	48.8	458	724	464	1424	2LC0381-4BA	2LC0381-4BC	1581
495-10	200	3700	567	380	495	380	312	232.4	33.8	387	706	406	1166	2LC0390-0BA	2LC0390-0BC	757
546-10	270	3300	624	420	546	420	351	220	40	413	714	414	1254	2LC0390-1BA	2LC0390-1BC	1010
587-10	350	3100	669	450	587	450	363	230	45	435	720	440	1340	2LC0390-2BA	2LC0390-2BC	1268
631-10	450	2900	719	480	631	480	399	242.4	48.8	458	724	464	1424	2LC0390-3BA	2LC0390-3BC	1578
694-10	630	2600	790	530	694	530	435	284	58	552	752	552	1612	2LC0390-4BA	2LC0390-4BC	2165
734-10	750	2500	830	560	734	560	459	314	63	600	764	604	1724	2LC0390-5BA	2LC0390-5BC	2586
790-10	950	2300	896	600	790	600	496	338	66	646	930	650	1850	2LC0390-6BA	2LC0390-6BC	3263
887-10	1400	2000	1013	680	887	680	546	394	78	749	956	756	2116	2LC0390-7BA	2LC0390-7BC	4716
988-10	2000	1800	1114	760	988	760	596	448	86	857	900	860	2380	2LC0390-8BA	2LC0390-8BC	6574

Configurable variants<sup>1)</sup>

- ØD1 Without finished bore  
With finished bore
- ØD2 Without finished bore  
With finished bore
- Shaft distance S <sup>2)</sup> Metric (mm): 100 mm, 140 mm, 180 mm, 200 mm, 250 mm, 300 mm  
Imperial (inches): 5" (127 mm), 7" (177.8 mm), 9" (228.6 mm)  
Any required (mm)

Notes

- Spacer sleeves (type MFEFM) designed as electrical cable sleeves are API compliant.
- Hubs are designed with threaded pull-off holes. Special lengths available upon request.
- The total lengths, the spacer lengths and the weights apply to the whole coupling of type MFEFM with maximum bores D1/D2 and the preferred shaft distance S = V.
- In cases with large shaft distances S the intermediate spacer can be designed as an H-spacer. The tube diameters here may slightly diverge. More precise coupling data in cases of variable shaft distances and E- / H-spacers are given on pages 6/23 to 6/25.
- Plate packs in the FEF/FHF intermediate unit assembled at the factory.
- E-spacers in preferred lengths up to size 343-6 are available from stock.

Ordering example

- N-ARPEX ARN-6 MFEFM coupling, size 217-6, with shaft distance S = 200 mm
- Bore ØD1 80H7 mm, keyway to DIN 6885-1 P9 and set screw (L1J)
- Bore ØD2 90H7 mm, keyway to DIN 6885-1 P9 and set screw (M1L)

Article no.: 2LC0370-8BA99-0AD0-Z L1J+M1L

<sup>1)</sup> To identify complete item numbers specifying the available finish boring options and – if necessary – further order options, please use our configurators on [flender.com](http://flender.com).  
<sup>2)</sup> The S shaft spacing standard dimensions available for each size can be found on Page 6/10.  
➤ For online configuration on [flender.com](http://flender.com), click on the item no.

# TYPE BEB

Torsionally rigid type BEB couplings with smallest possible shaft distance.

Type BEB cannot be freely demounted radially without shifting the units.

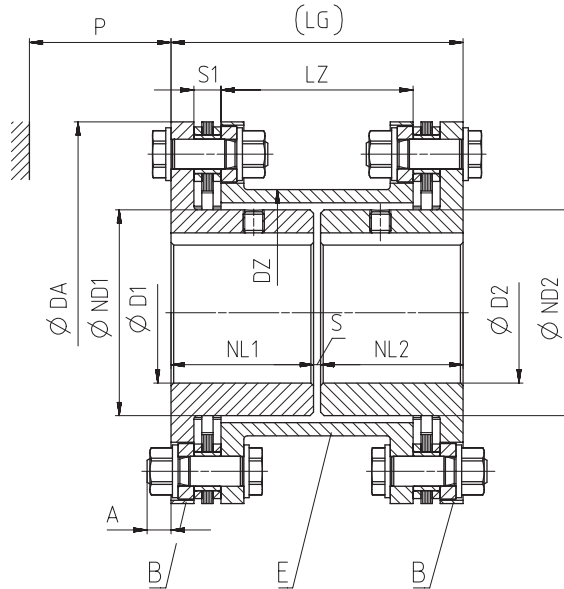

6

Size DA	Rated torque $T_{KN}$	Maximum speed $n_{Kmax}$	Dimensions in mm										Article no. <sup>1)</sup>	Weight m	
			D1/D2 Keyway DIN 6885-1 max.	ND1/ ND2	NL1/ NL2	DZ	LZ	S1	Shaft distance S	A	P	LG			kg
mm	kNm	rpm													
86-6	0.35	24000	22	35	30	45	44	8	12	8	32	72	SLC0370-0AB	1.5	
103-6	0.5	20000	38	50	34	60	43.2	8.4	4	8	32	72	SLC0370-1AB	2.0	
122-6	0.95	17000	48	62	56	73	82.4	8.8	4	8	38	116	2LC0370-2AB	4.2	
133-6	1.25	15000	55	72	56	85	80.8	9.6	4	7	38	116	2LC0370-3AB	5.1	
159-6	2.1	13000	65	84	57	97	76.8	11.6	6	9	48	120	2LC0370-4AB	8.1	
174-6	2.5	12000	75	102	77	116	114.4	12.8	4	10	48	158	2LC0370-5AB	11.4	
184-6	3.8	11000	80	106	80	123	110.8	14.6	6	15	64	166	2LC0370-6AB	15.2	
203-6	5	10000	85	111	80	128	110	15	6	14	64	166	2LC0370-7AB	18.2	
217-6	6.2	9500	90	124	81	140	109.2	15.4	4	14	66	166	2LC0370-8AB	22.0	
251-6	10.5	8000	100	137	102	160	138.8	20.6	6	15	77	210	2LC0371-0AB	35.6	
268-6	13.8	7500	108	143	105	166	136	22	12	11	89	222	2LC0371-1AB	44.8	
291-6	18.2	7000	120	162	106	188	134.4	22.8	10	11	89	222	2LC0371-2AB	56.7	
318-6	23	6500	130	164	118	197	153.6	23.2	6	20	100	242	2LC0371-3AB	70.2	
343-6	28	6000	150	186	143	223	202	24	6	19	100	292	2LC0371-4AB	87.7	

### Configurable variants <sup>1)</sup>

- ØD1 Without finished bore  
With finished bore
- ØD2 Without finished bore  
With finished bore

### Notes

- Hubs are designed with threaded pull-off holes. Special lengths available upon request.
- The total lengths and the weights apply to the whole coupling with maximum bores D1/D2 and the preferred shaft distance S = V.

<sup>1)</sup> To identify complete item numbers specifying the available finish boring options and – if necessary – further order options, please use our configurators on [flender.com](http://flender.com).

### Ordering example

- N-ARPEX ARN-6 BEB coupling, size 217-6, with shaft distance S = 4 mm
- Bore ØD1 50H7 mm, keyway to DIN 6885-1 and set screw **(L1C)**
- Bore ØD2 60H7 mm, keyway to DIN 6885-1 and set screw **(M1E)**

Article no.: **2LC0370-8AB99-0AA0-Z L1C+M1E**

➤ For online configuration on [flender.com](http://flender.com), click on the item no.

# FURTHER HUBS

## Clamping hubs, type 124 and 125

Type 124 and 125 standard clamping hubs can be combined with any spacer of the ARN-6 series.

It should be noted that the clamping hub can be used only as an "N hub" (hub core outside).

### Function

N-ARPEX clamping hubs transmit torque with the aid of a flexible press fit. By pulling the clamping ring on by means of the tightening screws the necessary surface pressure

is applied in the "shaft/hub" contact area. After the tightening operation the clamping ring lies up against the clamping hub.

### Transmissible torque

The clamping connections are designed to enable the specified maximum torques to be transmitted.

These maximum torques must not be exceeded, even in the case of overload.

### Fitting clearance and surface roughness

The transmissible torques allow for the maximum fitting clearance for a quality IT6 bore and shaft and maximum surface roughness. For other shaft tolerances reduced torques or other bore tolerances must be used. The surface roughness of the shaft should be  $\leq Ra = 1.6 \mu m$ .

**The fit pairing G6/h6 should be used wherever possible.** Divergent shaft tolerances must be specified when ordering. The article no. for the specification must end in "-Z" and include the code "Y26" for the fit.

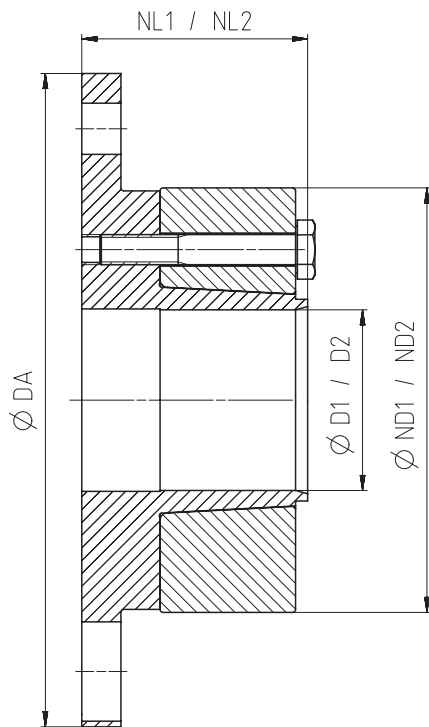

Type 124 (standard type)

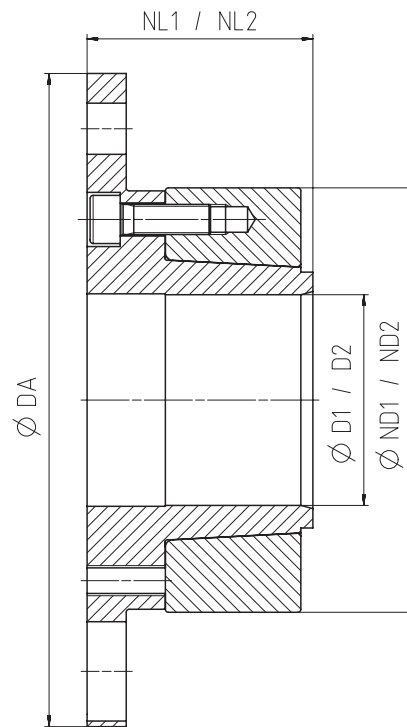

Type 125

# FURTHER HUBS

Clamping hubs, type 124 and 125

Size DA mm	Clamping hub Type	Dimensions in mm		ND1/ND2	NL1/NL2	Mass moment of inertia <i>J</i> kgm <sup>2</sup>	↗ Article no. <sup>1)</sup>	Weight <i>m</i> kg
		D1/D2 min.	max.					
86-6	124	19	25	50	35	0.0003	2LC0370-0LM90-0AA0 2LC0370-0LN90-0AA0	0.5
	125							
103-6	124	25	38	67	40	0.0009	2LC0370-1LM90-0AA0 2LC0370-1LN90-0AA0	0.9
	125							
122-6	124	30	42	77	45	0.0021	2LC0370-2LM90-0AA0 2LC0370-2LN90-0AA0	1.5
	125							
133-6	124	32	50	88	50	0.0034	2LC0370-3LM90-0AA0 2LC0370-3LN90-0AA0	2
	125							
159-6	124	35	60	105	55	0.0077	2LC0370-4LM90-0AA0 2LC0370-4LN90-0AA0	3.2
	125							
174-6	124	40	70	120	65	0.0135	2LC0370-5LM90-0AA0 2LC0370-5LN90-0AA0	4.6
	125							
184-6	124	45	70	126	70	0.0195	2LC0370-6LM90-0AA0 2LC0370-6LN90-0AA0	5.9
	125							
203-6	124	50	80	139	75	0.0298	2LC0370-7LM90-0AA0 2LC0370-7LN90-0AA0	7.4
	125							
217-6	124	60	90	147	90	0.0429	2LC0370-8LM90-0AA0 2LC0370-8LN90-0AA0	9.2
	125							
251-6	124	70	95	168	95	0.0837	2LC0371-0LM90-0AA0 2LC0371-0LN90-0AA0	14
	125							
268-6	124	75	100	175	115	0.1236	2LC0371-1LM90-0AA0 2LC0371-1LN90-0AA0	18.5
	125							
291-6	124	80	120	195	125	0.1907	2LC0371-2LM90-0AA0 2LC0371-2LN90-0AA0	22.9
	125							
318-6	124	85	120	209	140	0.2975	2LC0371-3LM90-0AA0 2LC0371-3LN90-0AA0	31.5
	125							
343-6	124	95	140	234	150	0.4539	2LC0371-4LM90-0AA0 2LC0371-4LN90-0AA0	39.6
	125							

## Note

- Weights and mass moments of inertia apply to a clamping hub with a maximum bore D1/D2.

## Ordering example:

- N-ARPEX clamping hub, type 124, size 133-6
- Shaft ØD1 = 40k6 (**LOW**)

- Y26** / fit specification supplied

Article no.: 2LC0370-3LM90-0AA0-Z L0W+Y26

Plain text Y26: k6

<sup>1)</sup> To identify complete item numbers specifying the available finish boring options and – if necessary – further order options, please use our configurators on [flender.com](https://www.flender.com).

↗ For online configuration on [flender.com](https://www.flender.com), click on the item no.



## Dimensions and torques

Finished bore/shaft in standard fit	DA size in mm													
	86-6	103-6	122-6	133-6	159-6	174-6	184-6	203-6	217-6	251-6	268-6	291-6	318-6	343-6
D1 <sup>64</sup> / <sub>h6</sub> mm	Rated coupling torque $T_{KN}$ in Nm													
	350	500	950	1250	2100	2400	3800	5000	6200	10500	13800	18200	23000	28000
	Maximum transmissible torque of the clamping hub Nm													
19	400	-	-	-	-	-	-	-	-	-	-	-	-	-
20	460	-	-	-	-	-	-	-	-	-	-	-	-	-
22	470	-	-	-	-	-	-	-	-	-	-	-	-	-
24	350	-	-	-	-	-	-	-	-	-	-	-	-	-
25	370	480	-	-	-	-	-	-	-	-	-	-	-	-
28	-	870	-	-	-	-	-	-	-	-	-	-	-	-
30	-	1150	1770	-	-	-	-	-	-	-	-	-	-	-
32	-	1140	1830	2300	-	-	-	-	-	-	-	-	-	-
35	-	570	1420	2360	3050	-	-	-	-	-	-	-	-	-
38	-	830	1720	3040	2710	-	-	-	-	-	-	-	-	-
40	-	-	1370	2610	3660	3680	-	-	-	-	-	-	-	-
42	-	-	1670	2930	2180	4020	-	-	-	-	-	-	-	-
45	-	-	-	2120	3750	4110	5780	-	-	-	-	-	-	-
48	-	-	-	2480	4160	4930	6200	-	-	-	-	-	-	-
50	-	-	-	2240	2300	4300	5840	7190	-	-	-	-	-	-
55	-	-	-	-	3310	5370	6410	7970	-	-	-	-	-	-
60	-	-	-	-	3260	3730	5370	8840	7570	-	-	-	-	-
65	-	-	-	-	-	4700	6240	8890	10390	-	-	-	-	-
70	-	-	-	-	-	4150	5920	8460	10640	14050	-	-	-	-
75	-	-	-	-	-	-	-	7960	9590	15350	20710	-	-	-
80	-	-	-	-	-	-	-	7340	8850	13510	20120	31840	-	-
85	-	-	-	-	-	-	-	-	7890	16370	21130	31230	36420	-
90	-	-	-	-	-	-	-	-	6290	14300	20810	33300	39050	-
95	-	-	-	-	-	-	-	-	-	13310	18570	33530	35940	54230
100	-	-	-	-	-	-	-	-	-	-	14440	31710	37500	56580
110	-	-	-	-	-	-	-	-	-	-	-	29020	35200	56900
120	-	-	-	-	-	-	-	-	-	-	-	22600	31490	53580
130	-	-	-	-	-	-	-	-	-	-	-	-	-	50910
140	-	-	-	-	-	-	-	-	-	-	-	-	-	43600

### Note

- The maximum transmissible torque of the clamping hub must not be exceeded! Further clamping hub sizes and higher torques on request.

# SPARE AND WEAR PARTS

## Plate pack

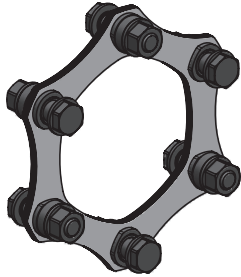

Size 86-6 to 343-6  
(hexagon plates)

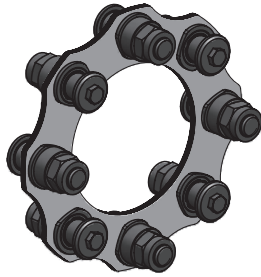

Size 219-8 to 631-8  
(octagon plates)

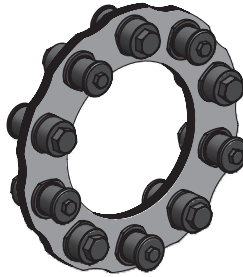

Size 495-10 to 631-10  
(decagon plates)

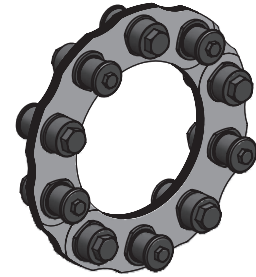

Size 694-10 to 988-10  
(decagon plates/segment)

6

Size	Dimensions	Mass moment of inertia	Article No.	Weight
DA	S1 mm	J kgm <sup>2</sup>		m kg
86-6	8	0.00018	2LC0370-0LP00-0AA0	0.17
103-6	8.4	0.00032	2LC0370-1LP00-0AA0	0.19
122-6	8.8	0.001	2LC0370-2LP00-0AA0	0.43
133-6	9.6	0.0014	2LC0370-3LP00-0AA0	0.49
159-6	11.6	0.0033	2LC0370-4LP00-0AA0	0.8
174-6	12.8	0.0047	2LC0370-5LP00-0AA0	0.93
184-6	14.6	0.0078	2LC0370-6LP00-0AA0	1.38
203-6	15	0.012	2LC0370-7LP00-0AA0	1.79
217-6	15.4	0.018	2LC0370-8LP00-0AA0	2.25
251-6	20.6	0.037	2LC0371-0LP00-0AA0	3.61
268-6	22	0.056	2LC0371-1LP00-0AA0	4.83
291-6	22.8	0.08	2LC0371-2LP00-0AA0	5.78
318-6	23.2	0.13	2LC0371-3LP00-0AA0	8.12
343-6	24	0.17	2LC0371-4LP00-0AA0	8.68
219-8	12.2	0.028	2LC0380-0LP00-0AA0	3.58
241-8	12.6	0.042	2LC0380-1LP00-0AA0	4.67
262-8	13.8	0.067	2LC0380-2LP00-0AA0	6.05
285-8	15.2	0.11	2LC0380-3LP00-0AA0	8.28
302-8	17.2	0.15	2LC0380-4LP00-0AA0	10.3
321-8	21	0.22	2LC0380-5LP00-0AA0	13.6
354-8	23.6	0.34	2LC0380-6LP00-0AA0	17
387-8	26	0.49	2LC0380-7LP00-0AA0	20.2
411-8	29.6	0.7	2LC0380-8LP00-0AA0	26
447-8	32.6	1.01	2LC0381-0LP00-0AA0	31.5
495-8	33.8	1.54	2LC0381-1LP00-0AA0	38.7
546-8	40	2.57	2LC0381-2LP00-0AA0	52.9
587-8	45	3.74	2LC0381-3LP00-0AA0	67.2
631-8	48.8	5.38	2LC0381-4LP00-0AA0	85
495-10	33.8	1.76	2LC0390-0LP00-0AA0	43.4
546-10	40	2.9	2LC0390-1LP00-0AA0	58.5
587-10	45	4.19	2LC0390-2LP00-0AA0	73.7
631-10	48.8	5.98	2LC0390-3LP00-0AA0	92.6
694-10	58	11.8	2LC0390-4LP00-0AA0	148
734-10	63	16.3	2LC0390-5LP00-0AA0	182
790-10	66	23.4	2LC0390-6LP00-0AA0	226
887-10	78	43.7	2LC0390-7LP00-0AA0	335
988-10	86	75.8	2LC0390-8LP00-0AA0	468

### Notes

- The plate pack of the ARN-6/-8 series is readily available as a spare part.
- The plate pack is delivered with screw connection.
- Mainly ring plates are used for the plate packs. Sizes 694-10 to 988-10 plate packs are designed with segmented plates.

### Ordering example

- N-ARPEX ARN-8 plate pack, size 354-8, complete with screw connection

Article no.: 2LC0380-6LP00-0AA0

# LENGTH-DEPENDENT SPECIFICATIONS

of types NEN/ NHN, BEB, MCECM/MCHCM and MFEFM/MFHFM

A variant with an E-spacer is standardly provided for each N-ARPEX type. This has been machined all over in accordance with the requirements of **API 610** and **671**. Particularly for large shaft distances *S* and therefore for correspondingly long intermediate spacer it is usual to leave the inside and outside diameters of the tube in the condition in which it was delivered. These spacers are then referred to as H-spacers.

If a coupling is fitted with an H-spacer, the type designation changes accordingly. For example, an NEN becomes an NHN, an MFEFM becomes an MFHFN. No version with an H-spacer is provided for the BEB type. Length-dependent technical specifications for the various coupling types are shown on the following table.

The shaft distance *S* must be specified in mm. The specifications with regard to weight and mass moment of inertia refer to the whole coupling with maximum bores *D1/ D2*.

The values for torsional stiffness apply to the whole coupling (not including the hubs and customer shafts) and refer to the rated coupling torque  $T_{KN}$ . For determination of torsional stiffness for a specific operating point outside the nominal range Flender must be consulted.

Variant with E spacer



Size DA	Type	<i>m</i> kg	<i>J</i> kgm <sup>2</sup>	<i>C</i> MNm/rad
86-6	NEN	1.55 + 0.003 · <i>S</i>	0.001 + 0.000002 · <i>S</i>	1/(1/0,08 + <i>S</i> /15)
	BEB	1.42 + 0.003 · <i>S</i>	0.001 + 0.000002 · <i>S</i>	1/(1/0,06 + <i>S</i> /15)
	MCECM	2.64 + 0.003 · <i>S</i>	0.003 + 0.000002 · <i>S</i>	1/(1/0,09 + <i>S</i> /15)
	MFEFM	5.54 + 0.003 · <i>S</i>	0.01 + 0.000002 · <i>S</i>	1/(1/0,09 + <i>S</i> /15)
103-6	NEN	2.52 + 0.005 · <i>S</i>	0.004 + 0.000004 · <i>S</i>	1/(1/0,11 + <i>S</i> /42)
	BEB	2.01 + 0.005 · <i>S</i>	0.003 + 0.000004 · <i>S</i>	1/(1/0,1 + <i>S</i> /42)
	MCECM	4 + 0.005 · <i>S</i>	0.006 + 0.000004 · <i>S</i>	1/(1/0,12 + <i>S</i> /42)
	MFEFM	7.28 + 0.005 · <i>S</i>	0.017 + 0.000004 · <i>S</i>	1/(1/0,12 + <i>S</i> /42)
122-6	NEN	4.39 + 0.007 · <i>S</i>	0.009 + 0.000008 · <i>S</i>	1/(1/0,26 + <i>S</i> /82)
	BEB	4.19 + 0.007 · <i>S</i>	0.008 + 0.000008 · <i>S</i>	1/(1/0,2 + <i>S</i> /82)
	MCECM	6.78 + 0.007 · <i>S</i>	0.015 + 0.000008 · <i>S</i>	1/(1/0,29 + <i>S</i> /82)
	MFEFM	12.6 + 0.007 · <i>S</i>	0.042 + 0.000008 · <i>S</i>	1/(1/0,29 + <i>S</i> /82)
133-6	NEN	5.5 + 0.009 · <i>S</i>	0.013 + 0.000014 · <i>S</i>	1/(1/0,33 + <i>S</i> /142)
	BEB	5.09 + 0.009 · <i>S</i>	0.011 + 0.000014 · <i>S</i>	1/(1/0,27 + <i>S</i> /142)
	MCECM	8.44 + 0.009 · <i>S</i>	0.023 + 0.000014 · <i>S</i>	1/(1/0,36 + <i>S</i> /142)
	MFEFM	15.86 + 0.009 · <i>S</i>	0.064 + 0.000014 · <i>S</i>	1/(1/0,36 + <i>S</i> /142)
159-6	NEN	8.54 + 0.011 · <i>S</i>	0.028 + 0.000023 · <i>S</i>	1/(1/0,54 + <i>S</i> /234)
	BEB	8 + 0.011 · <i>S</i>	0.026 + 0.000023 · <i>S</i>	1/(1/0,45 + <i>S</i> /234)
	MCECM	14.35 + 0.011 · <i>S</i>	0.055 + 0.000023 · <i>S</i>	1/(1/0,6 + <i>S</i> /234)
	MFEFM	21.37 + 0.011 · <i>S</i>	0.068 + 0.000023 · <i>S</i>	1/(1/0,6 + <i>S</i> /234)

Variant with H spacer

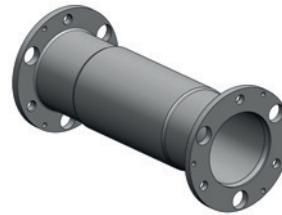

Size DA	Type	<i>m</i> kg	<i>J</i> kgm <sup>2</sup>	<i>C</i> MNm/rad
86-6	NHN	1.11 + 0.005 · <i>S</i>	0.001 + 0.000003 · <i>S</i>	1/(1/0,05 + <i>S</i> /25)
	-	-	-	-
	MCHCM	2.13 + 0.005 · <i>S</i>	0.003 + 0.000003 · <i>S</i>	1/(1/0,06 + <i>S</i> /25)
	MFHFM	5.03 + 0.005 · <i>S</i>	0.01 + 0.000003 · <i>S</i>	1/(1/0,06 + <i>S</i> /25)
103-6	NHN	1.91 + 0.008 · <i>S</i>	0.003 + 0.000007 · <i>S</i>	1/(1/0,09 + <i>S</i> /68)
	-	-	-	-
	MCHCM	3.28 + 0.008 · <i>S</i>	0.006 + 0.000007 · <i>S</i>	1/(1/0,1 + <i>S</i> /68)
	MFHFM	6.56 + 0.008 · <i>S</i>	0.016 + 0.000007 · <i>S</i>	1/(1/0,1 + <i>S</i> /68)
122-6	NHN	3.72 + 0.01 · <i>S</i>	0.008 + 0.000012 · <i>S</i>	1/(1/0,21 + <i>S</i> /122)
	-	-	-	-
	MCHCM	6 + 0.01 · <i>S</i>	0.014 + 0.000012 · <i>S</i>	1/(1/0,22 + <i>S</i> /122)
	MFHFM	11.82 + 0.01 · <i>S</i>	0.041 + 0.000012 · <i>S</i>	1/(1/0,22 + <i>S</i> /122)
133-6	NHN	4.52 + 0.013 · <i>S</i>	0.012 + 0.000022 · <i>S</i>	1/(1/0,28 + <i>S</i> /221)
	-	-	-	-
	MCHCM	7.29 + 0.013 · <i>S</i>	0.021 + 0.000022 · <i>S</i>	1/(1/0,29 + <i>S</i> /221)
	MFHFM	14.71 + 0.013 · <i>S</i>	0.062 + 0.000022 · <i>S</i>	1/(1/0,29 + <i>S</i> /221)
159-6	NHN	7.17 + 0.017 · <i>S</i>	0.025 + 0.000037 · <i>S</i>	1/(1/0,45 + <i>S</i> /373)
	-	-	-	-
	MCHCM	12.76 + 0.017 · <i>S</i>	0.051 + 0.000037 · <i>S</i>	1/(1/0,47 + <i>S</i> /373)
	MFHFM	19.78 + 0.017 · <i>S</i>	0.064 + 0.000037 · <i>S</i>	1/(1/0,47 + <i>S</i> /373)

# LENGTH-DEPENDENT SPECIFICATIONS

of types NEN/ NHN, BEB, MCECM/MCHCM and MFEFM/MFHFM

Variant with E spacer



Variant with H spacer



6

Size DA	Type	m kg	J kgm <sup>2</sup>	C MNm/rad
174-6	NEN	10.57 + 0.013 · S	0.042 + 0.000039 · S	1/(1/0,64 + S/394)
	BEB	11.36 + 0.013 · S	0.041 + 0.000039 · S	1/(1/0,52 + S/394)
	MCECM	17.54 + 0.013 · S	0.08 + 0.000039 · S	1/(1/0,68 + S/394)
	MFEFM	25.02 + 0.013 · S	0.146 + 0.000039 · S	1/(1/0,68 + S/394)
184-6	NEN	13.94 + 0.017 · S	0.065 + 0.000059 · S	1/(1/1 + S/597)
	BEB	15.1 + 0.017 · S	0.066 + 0.000059 · S	1/(1/0,81 + S/597)
	MCECM	23.12 + 0.017 · S	0.081 + 0.000059 · S	1/(1/1,11 + S/597)
	MFEFM	36.59 + 0.017 · S	0.267 + 0.000059 · S	1/(1/1,11 + S/597)
203-6	NEN	18.62 + 0.019 · S	0.102 + 0.00007 · S	1/(1/1,44 + S/705)
	BEB	18.09 + 0.019 · S	0.096 + 0.00007 · S	1/(1/1,13 + S/705)
	MCECM	29.96 + 0.019 · S	0.185 + 0.00007 · S	1/(1/1,65 + S/705)
	MFEFM	49.06 + 0.019 · S	0.414 + 0.00007 · S	1/(1/1,65 + S/705)
217-6	NEN	21.68 + 0.019 · S	0.137 + 0.000087 · S	1/(1/1,84 + S/870)
	BEB	21.93 + 0.019 · S	0.131 + 0.000087 · S	1/(1/1,43 + S/870)
	MCECM	36.46 + 0.019 · S	0.262 + 0.000087 · S	1/(1/2,11 + S/870)
	MFEFM	59.53 + 0.019 · S	0.579 + 0.000087 · S	1/(1/2,11 + S/870)
251-6	NEN	32.32 + 0.032 · S	0.271 + 0.00018 · S	1/(1/2,24 + S/1827)
	BEB	35.42 + 0.032 · S	0.276 + 0.00018 · S	1/(1/1,85 + S/1827)
	MCECM	56.48 + 0.032 · S	0.539 + 0.00018 · S	1/(1/2,45 + S/1827)
	MFEFM	101.1 + 0.032 · S	1.397 + 0.00018 · S	1/(1/2,45 + S/1827)
268-6	NEN	44.91 + 0.02 · S	0.434 + 0.00013 · S	1/(1/2,78 + S/2063)
	BEB	44.58 + 0.02 · S	0.425 + 0.00013 · S	1/(1/2,27 + S/2063)
	MCECM	73.71 + 0.02 · S	0.8 + 0.00013 · S	1/(1/3,07 + S/2063)
	MFEFM	131.4 + 0.02 · S	2.07 + 0.00013 · S	1/(1/3,07 + S/2063)
291-6	NEN	55.18 + 0.042 · S	0.634 + 0.00034 · S	1/(1/3,77 + S/3400)
	BEB	56.23 + 0.042 · S	0.624 + 0.00034 · S	1/(1/3,17 + S/3400)
	MCECM	87.66 + 0.042 · S	1.124 + 0.00034 · S	1/(1/4,09 + S/3400)
	MFEFM	176.8 + 0.042 · S	3.213 + 0.00034 · S	1/(1/4,09 + S/3400)
318-6	NEN	72.12 + 0.059 · S	0.979 + 0.0005 · S	1/(1/5,13 + S/5040)
	BEB	69.81 + 0.059 · S	0.922 + 0.0005 · S	1/(1/4,29 + S/5040)
	MCECM	121.4 + 0.059 · S	1.89 + 0.0005 · S	1/(1/5,72 + S/5040)
	MFEFM	203.7 + 0.059 · S	4.214 + 0.0005 · S	1/(1/5,72 + S/5040)
343-6	NEN	89.26 + 0.075 · S	1.394 + 0.00081 · S	1/(1/5,26 + S/8178)
	BEB	87.3 + 0.075 · S	1.322 + 0.00081 · S	1/(1/4,55 + S/8178)
	MCECM	145.8 + 0.075 · S	2.639 + 0.00081 · S	1/(1/5,62 + S/8178)
	MFEFM	261.5 + 0.075 · S	6.626 + 0.00081 · S	1/(1/5,62 + S/8178)

Size DA	Type	m kg	J kgm <sup>2</sup>	C MNm/rad
174-6	NHN	8.79 + 0.02 · S	0.036 + 0.000065 · S	1/(1/0,55 + S/652)
	-	-	-	-
	MCHCM	15.46 + 0.02 · S	0.073 + 0.000065 · S	1/(1/0,57 + S/652)
	MFHFM	22.95 + 0.02 · S	0.139 + 0.000065 · S	1/(1/0,57 + S/652)
184-6	NHN	12.36 + 0.023 · S	0.059 + 0.000083 · S	1/(1/0,89 + S/839)
	-	-	-	-
	MCHCM	21.18 + 0.023 · S	0.074 + 0.000083 · S	1/(1/0,95 + S/839)
	MFHFM	34.65 + 0.023 · S	0.259 + 0.000083 · S	1/(1/0,95 + S/839)
203-6	NHN	16.56 + 0.027 · S	0.093 + 0.0001 · S	1/(1/1,23 + S/1049)
	-	-	-	-
	MCHCM	27.42 + 0.027 · S	0.174 + 0.0001 · S	1/(1/1,33 + S/1049)
	MFHFM	46.52 + 0.027 · S	0.403 + 0.0001 · S	1/(1/1,33 + S/1049)
217-6	NHN	18.96 + 0.03 · S	0.123 + 0.00014 · S	1/(1/1,52 + S/1413)
	-	-	-	-
	MCHCM	33.11 + 0.03 · S	0.245 + 0.00014 · S	1/(1/1,63 + S/1413)
	MFHFM	56.18 + 0.03 · S	0.562 + 0.00014 · S	1/(1/1,63 + S/1413)
251-6	NHN	29.54 + 0.042 · S	0.253 + 0.00025 · S	1/(1/2,05 + S/2505)
	-	-	-	-
	MCHCM	53 + 0.042 · S	0.516 + 0.00025 · S	1/(1/2,18 + S/2505)
	MFHFM	97.57 + 0.042 · S	1.374 + 0.00025 · S	1/(1/2,18 + S/2505)
268-6	NHN	41.38 + 0.043 · S	0.41 + 0.00028 · S	1/(1/2,52 + S/2803)
	-	-	-	-
	MCHCM	68.56 + 0.043 · S	0.765 + 0.00028 · S	1/(1/2,69 + S/2803)
	MFHFM	126.3 + 0.043 · S	2.035 + 0.00028 · S	1/(1/2,69 + S/2803)
291-6	NHN	51.32 + 0.056 · S	0.598 + 0.00046 · S	1/(1/3,48 + S/4627)
	-	-	-	-
	MCHCM	82.87 + 0.056 · S	1.08 + 0.00046 · S	1/(1/3,67 + S/4627)
	MFHFM	171.4 + 0.056 · S	3.163 + 0.00046 · S	1/(1/3,67 + S/4627)
318-6	NHN	67.86 + 0.074 · S	0.936 + 0.00065 · S	1/(1/4,81 + S/6527)
	-	-	-	-
	MCHCM	115.6 + 0.074 · S	1.832 + 0.00065 · S	1/(1/5,2 + S/6527)
	MFHFM	198 + 0.074 · S	4.157 + 0.00065 · S	1/(1/5,2 + S/6527)
343-6	NHN	84.41 + 0.091 · S	1.332 + 0.001 · S	1/(1/5,07 + S/10323)
	-	-	-	-
	MCHCM	139.3 + 0.091 · S	2.556 + 0.001 · S	1/(1/5,33 + S/10323)
	MFHFM	255 + 0.091 · S	6.542 + 0.001 · S	1/(1/5,33 + S/10323)

Variant with E spacer



Size DA	Type	m kg	J kgm <sup>2</sup>	C MNm/rad
219-8	NEN	28.17 + 0.027 · S	0.177 + 0.000089 · S	1/(1/3,98 + S/889)
	MCECM	44.48 + 0.027 · S	0.338 + 0.000089 · S	1/(1/6,11 + S/889)
	MFEFM	71.89 + 0.027 · S	0.703 + 0.000089 · S	1/(1/6,11 + S/889)
241-8	NEN	36.79 + 0.032 · S	0.276 + 0.00013 · S	1/(1/4,69 + S/1264)
	MCECM	61.04 + 0.032 · S	0.56 + 0.00013 · S	1/(1/6,74 + S/1264)
	MFEFM	91.45 + 0.032 · S	1.074 + 0.00013 · S	1/(1/6,74 + S/1264)
262-8	NEN	46.53 + 0.04 · S	0.414 + 0.00019 · S	1/(1/5,4 + S/1884)
	MCECM	78.23 + 0.04 · S	0.846 + 0.00019 · S	1/(1/7,22 + S/1884)
	MFEFM	120.1 + 0.04 · S	1.692 + 0.00019 · S	1/(1/7,22 + S/1884)
285-8	NEN	61.59 + 0.051 · S	0.656 + 0.00028 · S	1/(1/7,04 + S/2836)
	MCECM	100.8 + 0.051 · S	1.315 + 0.00028 · S	1/(1/9,31 + S/2836)
	MFEFM	155 + 0.051 · S	2.552 + 0.00028 · S	1/(1/9,31 + S/2836)
302-8	NEN	78.21 + 0.062 · S	0.948 + 0.00039 · S	1/(1/9,87 + S/3948)
	MCECM	122.3 + 0.062 · S	1.774 + 0.00039 · S	1/(1/13,4 + S/3948)
	MFEFM	182 + 0.062 · S	3.359 + 0.00039 · S	1/(1/13,4 + S/3948)
321-8	NEN	96.07 + 0.066 · S	1.317 + 0.0005 · S	1/(1/13,9 + S/5053)
	MCECM	150 + 0.066 · S	2.469 + 0.0005 · S	1/(1/20,1 + S/5053)
	MFEFM	216.6 + 0.066 · S	4.48 + 0.0005 · S	1/(1/20,1 + S/5053)
354-8	NEN	129.1 + 0.079 · S	2.163 + 0.00079 · S	1/(1/18,2 + S/7977)
	MCECM	191.4 + 0.079 · S	3.866 + 0.00079 · S	1/(1/24,7 + S/7977)
	MFEFM	286.5 + 0.079 · S	7.246 + 0.00079 · S	1/(1/24,7 + S/7977)
387-8	NEN	169.6 + 0.093 · S	3.414 + 0.0012 · S	1/(1/25,3 + S/11742)
	MCECM	242.5 + 0.093 · S	5.88 + 0.0012 · S	1/(1/31,5 + S/11742)
	MFEFM	351.7 + 0.093 · S	10.62 + 0.0012 · S	1/(1/31,5 + S/11742)
411-8	NEN	201.9 + 0.113 · S	4.565 + 0.0015 · S	1/(1/29,4 + S/15183)
	MCECM	287.1 + 0.113 · S	7.821 + 0.0015 · S	1/(1/36 + S/15183)
	MFEFM	415.8 + 0.113 · S	14.1 + 0.0015 · S	1/(1/36 + S/15183)
447-8	NEN	260.7 + 0.129 · S	6.985 + 0.0021 · S	1/(1/38 + S/21062)
	MCECM	367.1 + 0.129 · S	11.74 + 0.0021 · S	1/(1/46,5 + S/21062)
	MFEFM	534.1 + 0.129 · S	21.22 + 0.0021 · S	1/(1/46,5 + S/21062)
495-8	NEN	354.4 + 0.157 · S	11.61 + 0.0033 · S	1/(1/46,4 + S/33418)
	MCECM	497.5 + 0.157 · S	19.74 + 0.0033 · S	1/(1/54,5 + S/33418)
	MFEFM	693.8 + 0.157 · S	33.95 + 0.0033 · S	1/(1/54,5 + S/33418)
546-8	NEN	483.3 + 0.212 · S	19.43 + 0.0056 · S	1/(1/59 + S/56448)
	MCECM	663.8 + 0.212 · S	32.27 + 0.0056 · S	1/(1/67 + S/56448)
	MFEFM	923.1 + 0.212 · S	55.39 + 0.0056 · S	1/(1/67 + S/56448)
587-8	NEN	600.7 + 0.279 · S	27.94 + 0.0076 · S	1/(1/67,3 + S/76570)
	MCECM	821.9 + 0.279 · S	45.85 + 0.0076 · S	1/(1/75,3 + S/76570)
	MFEFM	1147 + 0.279 · S	79.25 + 0.0076 · S	1/(1/75,3 + S/76570)
631-8	NEN	731.9 + 0.302 · S	39.04 + 0.01 · S	1/(1/79,6 + S/102143)
	MCECM	1006 + 0.302 · S	64.52 + 0.01 · S	1/(1/88,2 + S/102143)
	MFEFM	1441 + 0.302 · S	114.7 + 0.01 · S	1/(1/88,2 + S/102143)

Variant with H spacer



Size DA	Type	m kg	J kgm <sup>2</sup>	C MNm/rad
219-8	NHN	26.88 + 0.035 · S	0.172 + 0.00012 · S	1/(1/3,35 + S/1176)
	MCHCM	42.52 + 0.035 · S	0.33 + 0.00012 · S	1/(1/4,3 + S/1176)
	MFHFM	69.94 + 0.035 · S	0.695 + 0.00012 · S	1/(1/4,3 + S/1176)
241-8	NHN	34.62 + 0.044 · S	0.266 + 0.00018 · S	1/(1/3,88 + S/1760)
	MCHCM	57.91 + 0.044 · S	0.546 + 0.00018 · S	1/(1/4,73 + S/1760)
	MFHFM	88.32 + 0.044 · S	1.06 + 0.00018 · S	1/(1/4,73 + S/1760)
262-8	NHN	44.21 + 0.054 · S	0.402 + 0.00025 · S	1/(1/4,72 + S/2549)
	MCHCM	74.72 + 0.054 · S	0.828 + 0.00025 · S	1/(1/5,65 + S/2549)
	MFHFM	116.5 + 0.054 · S	1.673 + 0.00025 · S	1/(1/5,65 + S/2549)
285-8	NHN	59.68 + 0.064 · S	0.643 + 0.00035 · S	1/(1/6,46 + S/3534)
	MCHCM	97.63 + 0.064 · S	1.296 + 0.00035 · S	1/(1/7,87 + S/3534)
	MFHFM	151.8 + 0.064 · S	2.533 + 0.00035 · S	1/(1/7,87 + S/3534)
302-8	NHN	75.6 + 0.078 · S	0.928 + 0.00049 · S	1/(1/8,95 + S/4945)
	MCHCM	118.1 + 0.078 · S	1.744 + 0.00049 · S	1/(1/11,1 + S/4945)
	MFHFM	177.7 + 0.078 · S	3.329 + 0.00049 · S	1/(1/11,1 + S/4945)
321-8	NHN	92.41 + 0.086 · S	1.285 + 0.00065 · S	1/(1/12,2 + S/6577)
	MCHCM	144.2 + 0.086 · S	2.419 + 0.00065 · S	1/(1/15,4 + S/6577)
	MFHFM	210.8 + 0.086 · S	4.43 + 0.00065 · S	1/(1/15,4 + S/6577)
354-8	NHN	126 + 0.098 · S	2.129 + 0.00098 · S	1/(1/16,7 + S/9874)
	MCHCM	186 + 0.098 · S	3.809 + 0.00098 · S	1/(1/20,8 + S/9874)
	MFHFM	281.2 + 0.098 · S	7.189 + 0.00098 · S	1/(1/20,8 + S/9874)
387-8	NHN	164.5 + 0.122 · S	3.343 + 0.0015 · S	1/(1/22,8 + S/15253)
	MCHCM	234.9 + 0.122 · S	5.777 + 0.0015 · S	1/(1/26,4 + S/15253)
	MFHFM	344.1 + 0.122 · S	10.51 + 0.0015 · S	1/(1/26,4 + S/15253)
411-8	NHN	196.8 + 0.141 · S	4.49 + 0.0019 · S	1/(1/27,1 + S/18813)
	MCHCM	279.5 + 0.141 · S	7.712 + 0.0019 · S	1/(1/31,3 + S/18813)
	MFHFM	408.1 + 0.141 · S	13.99 + 0.0019 · S	1/(1/31,3 + S/18813)
447-8	NHN	255.1 + 0.157 · S	6.883 + 0.0026 · S	1/(1/35,1 + S/25615)
	MCHCM	358.7 + 0.157 · S	11.59 + 0.0026 · S	1/(1/40,9 + S/25615)
	MFHFM	525.6 + 0.157 · S	21.07 + 0.0026 · S	1/(1/40,9 + S/25615)
495-8	NHN	345 + 0.2 · S	11.39 + 0.0042 · S	1/(1/43 + S/42683)
	MCHCM	483.5 + 0.2 · S	19.42 + 0.0042 · S	1/(1/48,2 + S/42683)
	MFHFM	679.8 + 0.2 · S	33.62 + 0.0042 · S	1/(1/48,2 + S/42683)
546-8	NHN	474 + 0.255 · S	19.16 + 0.0068 · S	1/(1/56,3 + S/67807)
	MCHCM	649.6 + 0.255 · S	31.86 + 0.0068 · S	1/(1/62,2 + S/67807)
	MFHFM	908.9 + 0.255 · S	54.99 + 0.0068 · S	1/(1/62,2 + S/67807)
587-8	NHN	590 + 0.324 · S	27.6 + 0.0088 · S	1/(1/65 + S/88708)
	MCHCM	806 + 0.324 · S	45.37 + 0.0088 · S	1/(1/71,2 + S/88708)
	MFHFM	1131 + 0.324 · S	78.77 + 0.0088 · S	1/(1/71,2 + S/88708)
631-8	NHN	715.1 + 0.361 · S	38.39 + 0.012 · S	1/(1/76,3 + S/123294)
	MCHCM	981.7 + 0.361 · S	63.61 + 0.012 · S	1/(1/82,6 + S/123294)
	MFHFM	1417 + 0.361 · S	113.8 + 0.012 · S	1/(1/82,6 + S/123294)

# LENGTH-DEPENDENT SPECIFICATIONS

of types NEN/ NHN, BEB, MCECM/MCHCM and MFEFM/MFHFM

Variant with E spacer



Variant with H spacer



6

Size DA	Type	m kg	J kgm <sup>2</sup>	C MNm/rad
495-10	NEN	355.1 + 0.157 · S	11.7 + 0.0033 · S	1/(1/113 + S/33418)
	MFEFM	693 + 0.157 · S	33.97 + 0.0033 · S	1/(1/176 + S/33418)
546-10	NEN	483.7 + 0.212 · S	19.56 + 0.0056 · S	1/(1/138 + S/56448)
	MFEFM	921.8 + 0.212 · S	55.43 + 0.0056 · S	1/(1/190 + S/56448)
587-10	NEN	600.5 + 0.279 · S	28.09 + 0.0076 · S	1/(1/165 + S/76570)
	MFEFM	1145 + 0.279 · S	79.29 + 0.0076 · S	1/(1/223 + S/76570)
631-10	NEN	731.3 + 0.302 · S	39.23 + 0.01 · S	1/(1/187 + S/102143)
	MFEFM	1438 + 0.302 · S	114.8 + 0.01 · S	1/(1/241 + S/102143)
694-10	NEN	1057 + 0.39 · S	69.77 + 0.015 · S	1/(1/293 + S/154224)
	MFEFM	1950 + 0.39 · S	188.1 + 0.015 · S	1/(1/412 + S/154224)
734-10	NEN	1265 + 0.45 · S	94.03 + 0.02 · S	1/(1/373 + S/196935)
	MFEFM	2314 + 0.45 · S	248.7 + 0.02 · S	1/(1/542 + S/196935)
790-10	NEN	1587 + 0.53 · S	136.9 + 0.027 · S	1/(1/467 + S/270335)
	MFEFM	2919 + 0.53 · S	363.4 + 0.027 · S	1/(1/677 + S/270335)
887-10	NEN	2335 + 0.687 · S	256 + 0.042 · S	1/(1/644 + S/418343)
	MFEFM	4197 + 0.687 · S	665.8 + 0.042 · S	1/(1/944 + S/418343)
988-10	NEN	3264 + 0.975 · S	447.8 + 0.067 · S	1/(1/856 + S/675886)
	MFEFM	5736 + 0.975 · S	1129 + 0.067 · S	1/(1/1229 + S/675886)

Size DA	Type	m kg	J kgm <sup>2</sup>	C MNm/rad
495-10	NHN	345.7 + 0.2 · S	11.47 + 0.0042 · S	1/(1/94,7 + S/42683)
	MFHFM	678.9 + 0.2 · S	33.65 + 0.0042 · S	1/(1/124 + S/42683)
546-10	NHN	474.4 + 0.255 · S	19.28 + 0.0068 · S	1/(1/124 + S/67807)
	MFHFM	907.5 + 0.255 · S	55.03 + 0.0068 · S	1/(1/156 + S/67807)
587-10	NHN	589.9 + 0.324 · S	27.76 + 0.0088 · S	1/(1/152 + S/88708)
	MFHFM	1129 + 0.324 · S	78.81 + 0.0088 · S	1/(1/191 + S/88708)
631-10	NHN	714.5 + 0.361 · S	38.57 + 0.012 · S	1/(1/169 + S/123294)
	MFHFM	1414 + 0.361 · S	113.9 + 0.012 · S	1/(1/204 + S/123294)
694-10	NHN	1028 + 0.487 · S	68.47 + 0.019 · S	1/(1/257 + S/193881)
	MFHFM	1906 + 0.487 · S	186.2 + 0.019 · S	1/(1/322 + S/193881)
734-10	NHN	1229 + 0.563 · S	92.27 + 0.025 · S	1/(1/325 + S/247708)
	MFHFM	2260 + 0.563 · S	246.1 + 0.025 · S	1/(1/414 + S/247708)
790-10	NHN	1544 + 0.663 · S	134.4 + 0.034 · S	1/(1/409 + S/340076)
	MFHFM	2852 + 0.663 · S	359.6 + 0.034 · S	1/(1/522 + S/340076)
887-10	NHN	2278 + 0.844 · S	252 + 0.051 · S	1/(1/568 + S/517255)
	MFHFM	4107 + 0.844 · S	659.8 + 0.051 · S	1/(1/734 + S/517255)
988-10	NHN	3192 + 1.154 · S	441.8 + 0.08 · S	1/(1/774 + S/807126)
	MFHFM	5620 + 1.154 · S	1120 + 0.08 · S	1/(1/1006 + S/807126)

# OTHER DESIGN OPTIONS



Flange version for adaptation to a customer flange



Intermediate spacer as a torsion shaft for reducing the torsional stiffness

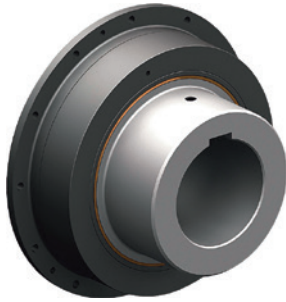

Slipping flanges for overload protection against brief high-frequency torque shock loads

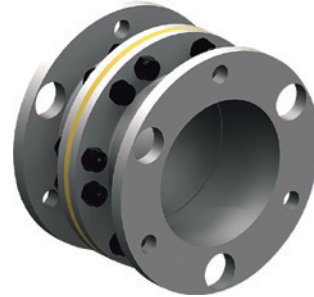

Version for avoiding leakage currents between the connected units



Slipping hubs for overload protection against brief high-frequency torque shock loads



Vertical support for avoiding excessive axial loading of the plate packs by the weight of the intermediate spacer

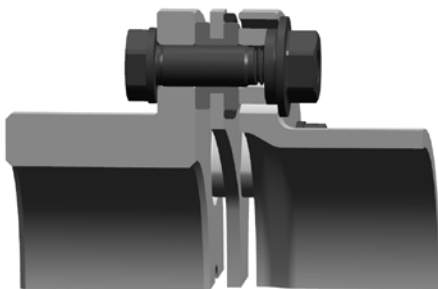

Axial backlash limiter



Brake disk/brake drum

# GENERAL

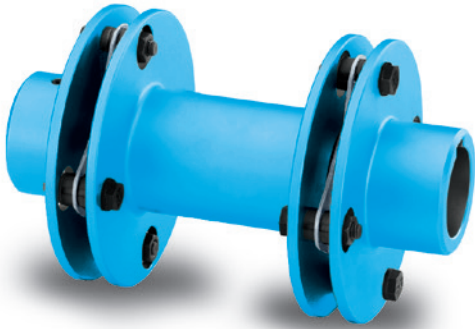

Coupling suitable for use in potentially explosive atmospheres.

Complies with the current ATEX Directive for:

CE  II 2G Ex h IIC T6 ... T2 Gb X

 II 2D Ex h IIIC T85 °C ... 250 °C Db X

 I M2 Ex h Mb X

6

## Benefits

ARPEX couplings of the ARW-4/-6 series are outstanding for their large angular misalignment capacity of 3°. They were specially designed for drives where high misalign-

ments which have to be compensated for by the coupling are to be expected. The intermediate spacer lengths are variable and are manufactured to customer specifications.

## Application

ARPEX couplings of the ARW-4/-6 series are used where large misalignment capacities are required. In the paper-making machine industry, the ARW coupling has already proved itself as a maintenance-free alternative to the cardan shaft. Torques of between 92 and 80000 Nm can be transmitted at a permitted angular misalignment of 3.0°. The intermediate spacer can be fitted radially without moving the connected units.

Main areas of application for the ARW-4/-6 series:

- Paper-making machines
- Wind power systems
- Traction drives



## Design and configurations

The design of an ARPEX NHN coupling of the ARW-4/-6 series is shown in the following illustration. The plate packs are bolted alternately between the flanges of the coupling hubs and the intermediate spacer. Up to size 292-4 close-fitting bolts and from size 324-4 conical screw connections are used for fastening.

Up to size 647-4 plate packs in rectangular design, from size 695-6 in hexagonal design are used. The intermediate spacers are variable in length and are manufactured specifically to customer specifications.

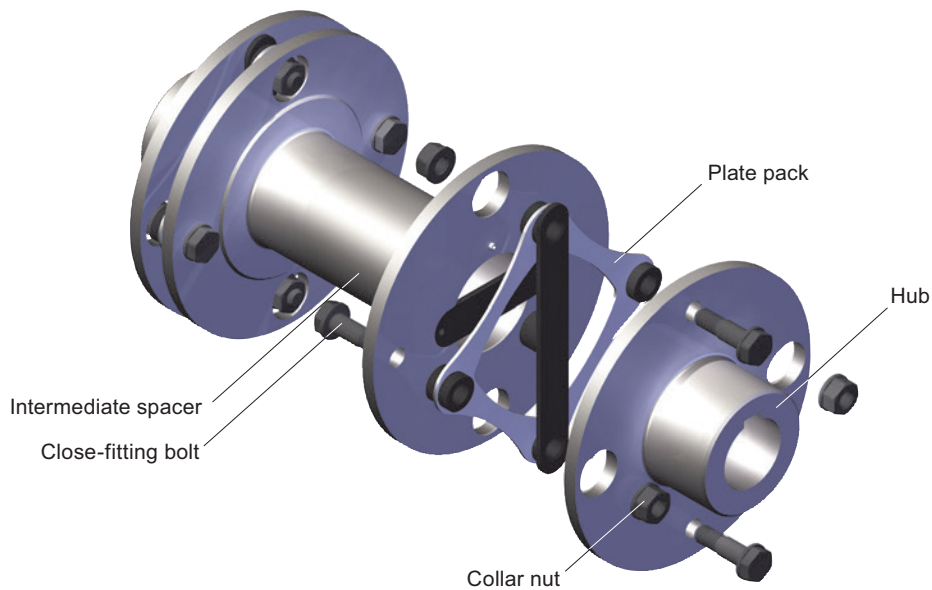

Variants of the ARPEX coupling, ARW-4/-6 series

G\_MD10\_EN\_00163a

## Variants of the ARPEX coupling, ARW-4/-6 series

Type	Description
NHN	Variant with unmachined intermediate spacer, with variable spacer length

The article number can be obtained with the help of the Configurator. The coupling can be selected in a product configurator and specified using selection menus.

The Configurator is available under [flender.com](https://www.flender.com)

The coupling can be selected via "Technical selection" (technical selection) or via "Direct selection" (via article-no.).

The coupling parts of the ARPEX ARW-4/-6 series with the exception of H spacers are machined on all sides. These are delivered with unmachined, primed spacer tube.

# GENERAL

## Technical specifications

Power ratings										
Size	Rated torque $T_{KN}$	Maximum torque $T_{Kmax}$	Overload torque $T_{KO/L}$	Fatigue torque $T_{KW}$	Maximum speed $n_{Kmax}$	Maximum permitted shaft misalignment				Torsional stiffness $C_{Tdyn}$
						+ $\Delta K_a$ Tension mm	- $\Delta K_a$ Compression mm	$\pm \Delta K_w$	$\pm \Delta K_r$ mm	
	Nm	Nm	Nm	Nm	rpm					MNm/rad
101-4	92	140	230	37	10400	2.4	2		51.8	0.006
133-4	225	340	560	90	7850	3.3	2.2		51.7	0.012
167-4	450	680	1130	180	6250	4.2	2.2		51.6	0.028
196-4	800	1200	2000	320	5350	5.1	2.2		51.6	0.068
230-4	1250	1880	3200	500	4550	5.7	2.2		51.6	0.108
260-4	2000	3000	5000	800	4000	6.6	2.2		51.5	0.174
292-4	2700	4100	6800	1080	3550	7.5	2.8		51.4	0.275
324-4	3850	5800	9700	1540	3200	8.4	2.8		51.4	0.451
355-4	5250	7900	13200	2100	2950	9	2.8		51.4	0.622
389-4	6650	10000	16700	2660	2700	10	2.8	3.0 °	51.4	0.657
439-4	9850	15000	25000	3940	2350	11.1	3		51.3	1.08
499-4	13300	20000	34000	5320	2100	12.4	4.8		50.8	1.32
547-4	19000	29000	48000	7600	1900	13.4	4.8		50.7	2.03
600-4	25150	38000	63000	10060	1750	14.6	4.8		50.6	2.73
647-4	32500	49000	82000	13000	1600	16	4.8		50.6	3.93
695-6	41000	62000	103000	16400	1500	17	4.8		50.7	10.1
756-6	52000	78000	130000	20800	1350	18	4.8		50.6	14
817-6	65000	98000	163000	26000	1250	20	4.8		50.5	16.9
880-6	80000	120000	200000	32000	1150	22	4.8		50.5	21.2

The radial misalignment  $\Delta K_r$  applies to a type NHN coupling with a shaft distance  $S = 1000$  mm. The radial misalignment  $\Delta K_r$  for other shaft distances  $S$  is calculated as follows:  $\Delta K_r = (S - S1) \cdot \tan(\Delta K_w)$

The permitted shaft misalignments  $\Delta K_a$ ,  $\Delta K_r$  and  $\Delta K_w$  are maximum values and must not occur at the same time (see following table).

The torsional stiffness values apply to the entire coupling with shaft distance  $S = 1000$  mm. The torsional stiffness of the plate packs applies to the rated coupling torque  $T_{KN}$ . To determine the torsional stiffness for a specific operating point, e.g. for calculating torsional vibration, the manufacturer must be consulted.

- $T_{Kmax}$  permitted only five times per hour.
- $T_{KW}$  for medium torque  $T_N = 0$  Nm.
- If  $T_N$  and  $T_{KW}$  occur at the same time, the manufacturer must be consulted.

Permitted shaft misalignments						
Size	Permitted angular misalignment $\Delta K_w$ (tension +)			Permitted angular misalignment $\Delta K_w$ (compression -)		
	3.0 °	1.5 °	0.0 °	3.0 °	1.5 °	0.0 °
	Permitted axial misalignment $\Delta K_a$ in mm			Permitted axial misalignment $\Delta K_a$ in mm		
101-4	0.8	1.6	2.4	0.8	1.6	2
133-4	1.1	2.2	3.3	1.1	2.2	2.2
167-4	1.4	2.8	4.2	1.4	2.2	2.2
196-4	1.7	3.4	5.1	1.7	2.2	2.2
230-4	1.9	3.8	5.7	1.9	2.2	2.2
260-4	2.2	4.4	6.6	2.2	2.2	2.2
292-4	2.5	5	7.5	2.5	2.8	2.8
324-4	2.8	5.6	8.4	2.8	2.8	2.8
355-4	3	6	9	2.8	2.8	2.8
389-4	3.3	6.7	10	2.8	2.8	2.8
439-4	3.7	7.4	11.1	3	3	3
499-4	4.1	8.3	12.4	4.1	4.8	4.8
547-4	4.5	8.9	13.4	4.4	4.8	4.8
600-4	4.9	9.7	14.6	4.8	4.8	4.8
647-4	5.3	10.7	16	4.8	4.8	4.8
695-6	5.6	11.4	17	4.8	4.8	4.8
756-6	6	12.1	18	4.8	4.8	4.8
817-6	6.7	13.4	20	4.8	4.8	4.8
880-6	7.3	14.8	22	4.8	4.8	4.8

Because of design specifications, the maximum possible axial shaft misalignment with plate packs pulled apart (**tension +**) is greater than with plate packs pressed together (**compression -**).

# TYPE NHN

Torsionally rigid type NHN coupling with high angular misalignment capacity up to 3° and radially freely dismountable intermediate spacer and variable shaft distance S.

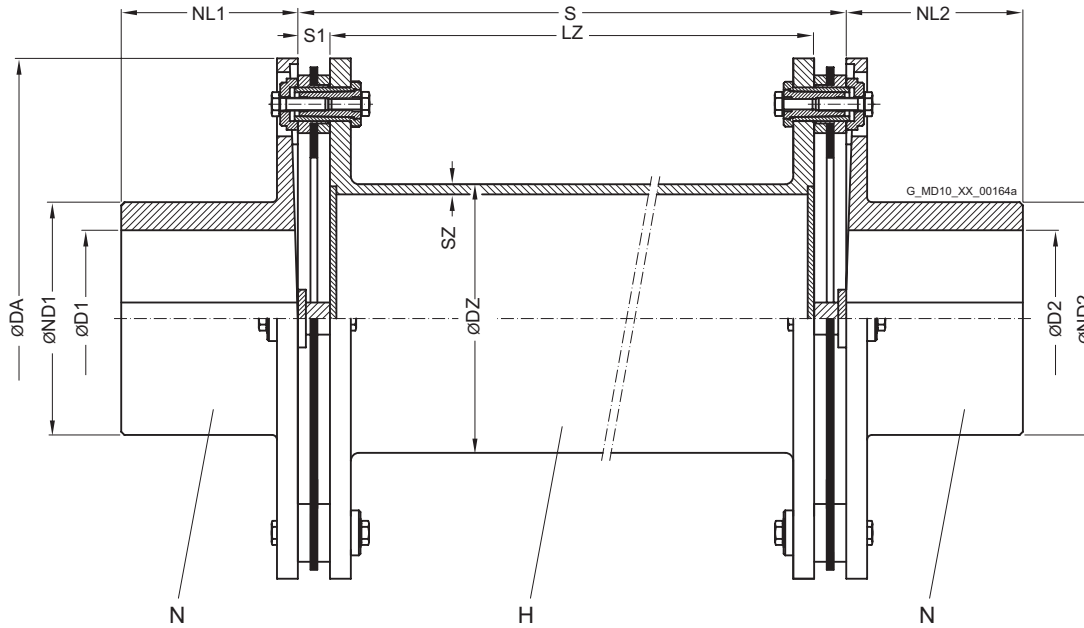

Size	Rated torque	Maximum speed	Dimensions in mm								Mass moment of inertia	Article no. <sup>1)</sup>	Weight
DA	$T_{KN}$	$n_{Kmax}$	D1, D2 Keyway DIN 6885 max.	ND1/ND2	DZ	SZ	NL1/NL2	S1	LZ	Shaft distance S	J		m
mm	Nm	rpm									kgm <sup>2</sup>		kg
101-4	92	10400	32	45	45	2.9	32	11	43	65	0.002	2LC0530-0AD	1.5
133-4	225	7850	45	60	48	2.9	45	13	59	85	0.008	2LC0530-1AD	3.9
167-4	450	6250	50	70	64	4	50	15	70	100	0.022	2LC0530-2AD	7.1
196-4	800	5350	60	80	89	4	60	16	83	115	0.056	2LC0530-3AD	12.1
230-4	1250	4550	75	100	102	5	75	16	83	115	0.109	2LC0530-4AD	17.9
260-4	2000	4000	90	120	133	5	90	17	96	130	0.189	2LC0530-5AD	24.6
292-4	2700	3550	100	130	152	5	100	19	92	130	0.359	2LC0530-6AD	35.1
324-4	3850	3200	110	145	168	6.3	110	20	120	160	0.52	2LC0530-7AD	43.7
355-4	5250	2950	120	160	178	7.1	120	20	125	165	0.856	2LC0530-8AD	59.8
389-4	6650	2700	130	175	194	7.1	130	20	130	170	1.09	2LC0531-0AD	68.9
439-4	9850	2350	150	200	219	7.1	150	22	166	210	2.23	2LC0531-1AD	106
499-4	13300	2100	165	220	245	7.1	165	30	170	230	3.81	2LC0531-2AD	142
547-4	19000	1900	190	250	299	8.8	190	32	176	240	6.24	2LC0531-3AD	191
600-4	25150	1750	205	275	324	8.8	205	34	182	250	10.2	2LC0531-4AD	257
647-4	32500	1600	225	300	343	10	225	35	220	290	16.5	2LC0531-5AD	348
695-6	41000	1500	240	325	368	10	240	33	224	290	23.7	2LC0540-0AD	441
756-6	52000	1350	255	340	394	12.5	255	34	232	300	33.2	2LC0540-1AD	525
817-6	65000	1250	270	360	406	12.5	270	36	238	310	49.1	2LC0540-2AD	659
880-6	80000	1150	300	400	419	12.5	300	37	256	330	72.8	2LC0540-3AD	849

### Configurable variants <sup>1)</sup>

- ØD1 Without finished bore  
With finished bore
- ØD2 Without finished bore  
With finished bore

<sup>1)</sup> To identify complete item numbers specifying the available finish boring options and – if necessary – further order options, please use our configurators on [flender.com](http://flender.com).

➤ For online configuration on [flender.com](http://flender.com), click on the item no.

Permitted shaft distance S of type NHN relative to speed

Size DA mm	Speed $n_N$ rpm												
	500	600	700	800	900	1000	1200	1400	1500	2000	2500	3000	4000
	Permitted shaft distance S in mm												
101-4	2822	2577	2387	2233	2106	1999	1825	1691	1634	1416	1268	1159	1005
133-4	2949	2693	2494	2334	2201	2089	1908	1767	1708	1481	1326	1212	1051
167-4	3376	3083	2856	2672	2520	2392	2185	2024	1956	1696	1518	1387	1203
196-4	4029	3679	3407	3188	3007	2854	2606	2414	2333	2022	1811	1654	1435
230-4	4297	3924	3634	3400	3207	3043	2779	2574	2488	2156	1930	1764	1530
260-4	4943	4514	4181	3912	3689	3500	3197	2961	2861	2480	2220	2028	1759
292-4	5305	4844	4487	4198	3959	3757	3431	3178	3071	2662	2383	2177	
324-4	5562	5079	4704	4401	4151	3939	3597	3332	3220	2791	2499	2283	
355-4	5709	5214	4828	4518	4261	4043	3692	3420	3305	2865	2564		
389-4	5968	5450	5047	4722	4453	4226	3859	3575	3454	2994	2680		
439-4	6361	5809	5380	5034	4747	4505	4114	3811	3682	3192			
499-4	6738	6154	5699	5333	5030	4773	4360	4039	3903	3384			
547-4	7442	6797	6295	5890	5555	5272	4815	4460	4310				
600-4	7762	7089	6565	6144	5794	5499	5022	4652	4496				
647-4	7980	7287	6750	6316	5957	5653	5163	4783	4622				
695-6	8000	7553	6995	6545	6173	5858	5350	4956	4789				
756-6	8000	7797	7221	6757	6372	6047	5523						
817-6	8000	7920	7335	6864	6473	6143	5611						
880-6	8000	8000	7456	6977	6580	6244							

Outside the permitted speed range

Notes

- The permitted length of the intermediate spacer depends on the maximum operating speed of the coupling. In the case of individual order of the intermediate spacer, the length (LZ) must be specified.
- Mass moments of inertia and weights apply to the entire NHN coupling with maximum bores D1/D2 and a shaft distance S = S min.

Ordering example

- ARPEX ARW-4 NHN coupling, size 133-4, with shaft distance S = 1000 mm,
- Bore ØD1 40H7 mm, with keyway to DIN 6885 and set screw
- Bore ØD2 45K7 mm, with keyway to DIN 6885 and set screw

Article no.: 2LC0530-1AD99-0AZ0-Z L0W+M1A+Q0Y+M13  
Plain text to Q0Y: S = 1000 mm

<sup>1)</sup> To identify complete item numbers specifying the available finish boring options and – if necessary – further order options, please use our configurators on [flender.com](http://flender.com).

↗ For online configuration on [flender.com](http://flender.com), click on the item no.

# SPARE AND WEAR PARTS

## Plate pack, ARW-4/-6 series

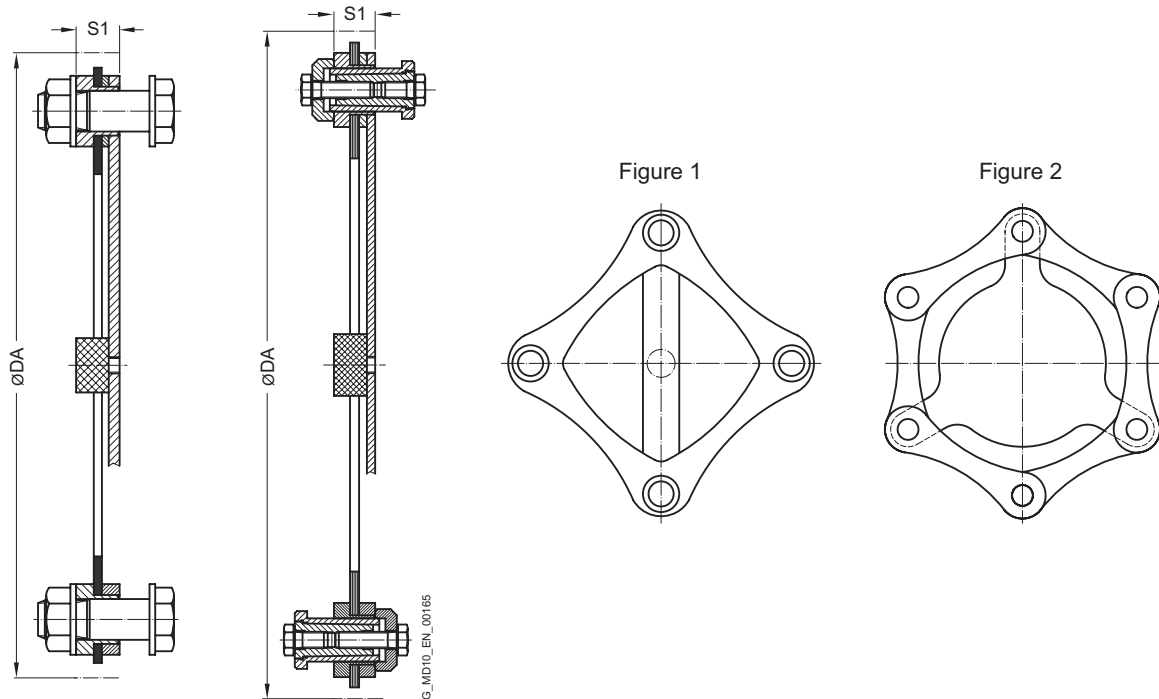

Size DA mm	Dimensions S1 mm	Mass moment of inertia $J$ kgm <sup>2</sup>	Article No.	Weight $m$ kg
101-4	11	0.0001	2LC0530-0AB00-0AA0	0.1
133-4	13	0.0005	2LC0530-1AB00-0AA0	0.2
167-4	15	0.0017	2LC0530-2AB00-0AA0	0.5
196-4	16	0.0037	2LC0530-3AB00-0AA0	0.7
230-4	16	0.0068	2LC0530-4AB00-0AA0	1
260-4	17	0.0136	2LC0530-5AB00-0AA0	1.5
292-4	19	0.0227	2LC0530-6AB00-0AA0	1.9
324-4	20	0.0288	2LC0530-7AB00-0AA0	2.1
355-4	20	0.0452	2LC0530-8AB00-0AA0	2.7
389-4	20	0.0645	2LC0531-0AB00-0AA0	3.2
439-4	22	0.1147	2LC0531-1AB00-0AA0	4.5
499-4	30	0.2235	2LC0531-2AB00-0AA0	6.9
547-4	32	0.3658	2LC0531-3AB00-0AA0	9.5
600-4	34	0.5355	2LC0531-4AB00-0AA0	11.4
647-4	35	0.7939	2LC0531-5AB00-0AA0	14.6
695-6	33	1.4624	2LC0540-0AB00-0AA0	24.6
756-6	34	1.225	2LC0540-1AB00-0AA0	20.2
817-6	36	1.7497	2LC0540-2AB00-0AA0	23.9
880-6	37	2.546	2LC0540-3AB00-0AA0	28.9

### Notes

- Plate packs of the ARW-4 series comprise ring plates (Fig. 1), those of the ARW-6 series side-bar plates (Fig. 2).
- The plate pack of the ARW-4/-6 series is readily available as a spare part.
- The plate pack is delivered with screw connection.
- Up to size 292-4 close-fitting bolts with collar nuts, from size 324-4 conical screw connections are used.

### Ordering example

- ARPEX ARW-4 plate pack, size 133-4, complete with screw connection.

Article no.: 2LC0530-1AB00-0AA0

# GENERAL



Coupling suitable for use in potentially explosive atmospheres.

Complies with the current ATEX Directive for:

CE II 2G Ex h IIC T6 ... T2 Gb X

II 2D Ex h IIIC T85 °C ... 250 °C Db X

I M2 Ex h Mb X

## Benefits

ARPEX couplings of the ARF-6 series are extremely short and so suitable for drives with short shaft distances. They also serve as self-aligning couplings for axial, angular and radial misalignment. The hubs are available both as pure clamping hubs for smooth shafts and with parallel keyway

for shafts with parallel key.

The variant with slit clamping hubs enables the delivery of fully preassembled couplings. This means that the entire coupling can be dismantled and fitted without moving the connected units.

## Application

ARPEX couplings of the ARF-6 series are designed for minimum fitting spaces without having to sacrifice the advantages of the two-joint coupling. It is thus possible to compensate for both axial and angular as well as radial misalignment. By using half-shell clamping hubs, the coupling can be radially freely dismantled. Power is transmitted via hexagon socket head cap screws and close-fitting bolts with nuts and ring plate packs in hexagonal design. Torques of between 120 and 6100 Nm can be transmitted at a permitted angular misalignment of 0.7°.

Main areas of application for the ARF-6 series:

- Film stretching machines
- Machines in the cellulose industry
- Machines in confined fitting situations

# GENERAL

## Design and configurations

The two plate packs form a unit with the adapter disk and are screwed together with close-fitting bolts and nuts at three points. The alternate connection of this intermediate unit with the flanges of the split coupling hubs is achieved by means of short hexagon socket head cap screws at further three points. The hubs are designed as axially slit

clamping hubs with a half-shell. For larger bores these can be manufactured as jumbo hubs. Optionally, the hubs are also available without parallel keyway.

6

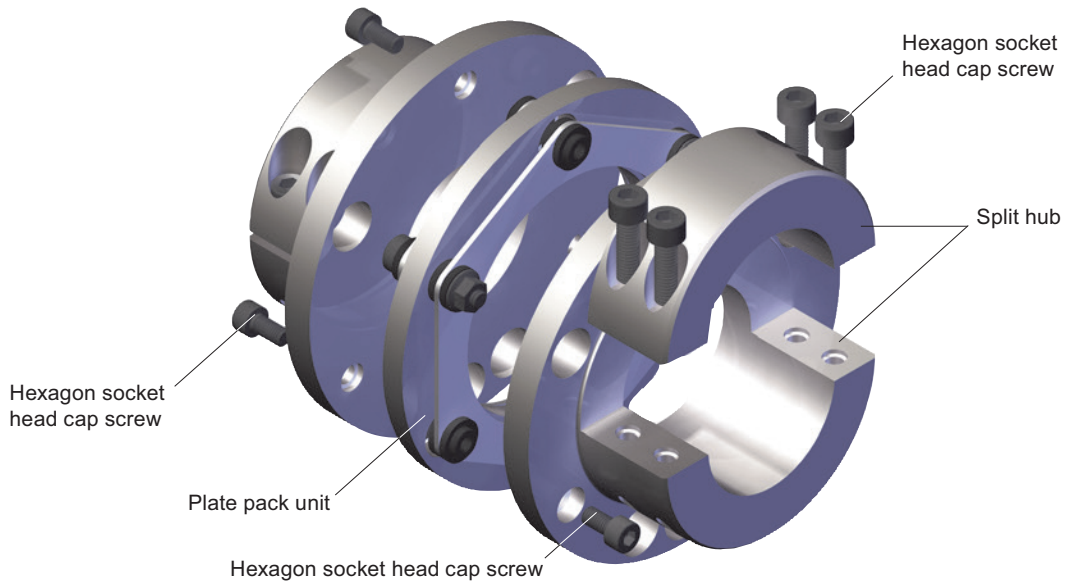

G\_MD10\_EN\_0016

Design of the ARPEX coupling, ARF series

## Variants of the ARF coupling

Type	Description
GG	Variant with 2 standard clamping hubs
GJ	Variant with 1 jumbo clamping hub for large bore diameters

The article number can be obtained with the help of the Configurator. The coupling can be selected in a product configurator and specified using selection menus.

The Configurator is available under [flender.com](http://flender.com)

The coupling can be selected via "Technical selection" (technical selection) or via "Direct selection" (via article-no.).



Technical specifications

Power ratings, types GG and GJ									
Size	Rated torque	Maximum torque	Overload torque	Fatigue torque	Maximum speed	Maximum permitted shaft misalignment			Torsional stiffness
	$T_{KN}$ Nm	$T_{Kmax}$ Nm	$T_{KOL}$ Nm	$T_{KW}$ Nm	$n_{Kmax}$ rpm	$\pm\Delta K_a$ mm	$\pm\Delta K_w$	$\pm\Delta K_r$ mm	$C_T$ MNm/rad
84-6	120	220	330	55	12500	1.1	0.7 °	0.16	0.07
111-6	190	350	520	90	9450	1.8		0.16	0.13
132-6	350	650	950	160	7950	2.02		0.2	0.2
147-6	500	900	1350	230	7100	2.4		0.2	0.28
171-6	900	1700	2450	400	6100	2.74		0.24	0.57
182-6	1450	2600	4000	650	5750	2.86		0.29	0.66
202-6	2150	3900	5800	980	5200	3.06		0.29	0.77
218-6	3200	5800	8700	1450	4800	3.14		0.37	1.25
252-6	4500	8100	12000	2000	4150	3.7		0.45	1.55
267-6	6100	11000	16500	2800	3900	3.84		0.46	1.8

The permitted shaft misalignments  $\Delta K_a$ ,  $\Delta K_r$  and  $\Delta K_w$  are maximum values and must not occur at the same time (see following table).

- $T_{Kmax}$  permitted only five times per hour.
- $T_{KW}$  for medium torque  $T_N = 0$  Nm.
- If  $T_N$  and  $T_{KW}$  occur at the same time, the manufacturer must be consulted.

The values for torsional stiffness apply to the complete coupling. The torsional stiffness of the plate packs applies to the rated coupling torque  $T_{KN}$ . To determine the torsional stiffness for a specific operating point, e.g. for calculating torsional vibration, the manufacturer must be consulted.

Permitted shaft misalignments									
Size	Permitted angular misalignment $\pm\Delta K_w$								
	0.0 °	0.1 °	0.2 °	0.3 °	0.4 °	0.5 °	0.6 °	0.7 °	
	Permitted axial misalignment $\pm\Delta K_a$ in mm								
84-6	1.1	0.94	0.79	0.63	0.47	0.31	0.16	0	
111-6	1.8	1.54	1.29	1.03	0.77	0.51	0.26	0	
132-6	2.02	1.73	1.44	1.15	0.87	0.58	0.29	0	
147-6	2.4	2.06	1.71	1.37	1.03	0.69	0.34	0	
171-6	2.74	2.35	1.96	1.57	1.17	0.78	0.39	0	
182-6	2.86	2.45	2.04	1.63	1.23	0.82	0.41	0	
202-6	3.06	2.62	2.19	1.75	1.31	0.87	0.44	0	
218-6	3.14	2.69	2.24	1.79	1.35	0.9	0.45	0	
252-6	3.7	3.17	2.64	2.11	1.59	1.06	0.53	0	
267-6	3.84	3.29	2.74	2.19	1.65	1.1	0.55	0	

# TYPES GG AND GJ

Radially freely dismountable, torsionally rigid coupling, available as types GG and GJ.

Complete dismounting without moving the units with extremely short shaft distances.

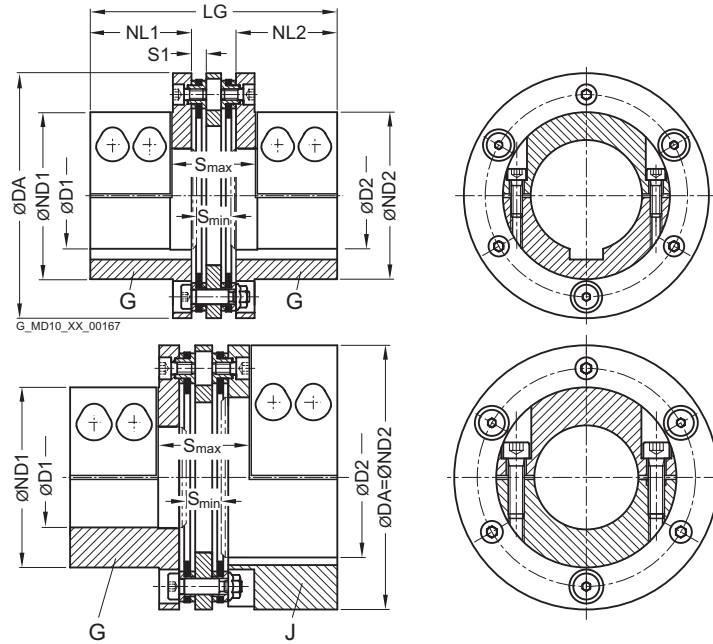

Size	Rated torque	Maximum speed	Type	Dimensions in mm										Mass moment of inertia J	Article no. <sup>1)</sup>	Weight
				DA	T <sub>KN</sub>	n <sub>Kmax</sub>	Keyway DIN 6885			ND1	ND2	NL1/NL2	S1			
mm	Nm	rpm		D1 max. Parallel key/ Clamping seat	D2 max. Parallel key	Clamping seat					min	max.	kgm <sup>2</sup>		kg	
84-6	120	12500	GG	25	25	25	50	50	40	6	16	39	99	0.0013	2LC0420-0AB99-0AA0	1.7
			GJ		40	48		84						0.0021	2LC0420-0AC99-0AA0	2.1
111-6	190	9450	GG	48	48	48	76	76	40	6	16	39	99	0.0043	2LC0420-1AB99-0AA0	2.9
			GJ		65	65		111						0.0067	2LC0420-1AC99-0AA0	3.6
132-6	350	7950	GG	52	52	52	90	90	55	8	18.5	45	134	0.011	2LC0420-2AB99-0AA0	5.7
			GJ		75	80		132						0.0177	2LC0420-2AC99-0AA0	7
147-6	500	7100	GG	60	60	60	105	105	65	8	18.5	45	154	0.0199	2LC0420-3AB99-0AA0	8.3
			GJ		85	85		147						0.0324	2LC0420-3AC99-0AA0	10.4
171-6	900	6100	GG	70	70	70	122	122	75	9	22.5	56	179	0.0439	2LC0420-4AB99-0AA0	13.3
			GJ		100	100		171						0.0695	2LC0420-4AC99-0AA0	16.4
182-6	1450	5750	GG	70	70	70	126	126	85	11	29	71	205	0.0649	2LC0420-5AB99-0AA0	17.5
			GJ		100	110		182						0.1005	2LC0420-5AC99-0AA0	20.9
202-6	2150	5200	GG	75	75	75	138	138	85	11	29	71	205	0.0986	2LC0420-6AB99-0AA0	21.9
			GJ		115	125		202						0.1519	2LC0420-6AC99-0AA0	25.6
218-6	3200	4800	GG	90	90	90	149	149	95	14	35	86	234	0.1499	2LC0420-7AB99-0AA0	27.2
			GJ		130	130		218						0.2345	2LC0420-7AC99-0AA0	33.6
252-6	4500	4150	GG	100	100	100	166	166	105	17	40.5	101	264	0.2924	2LC0420-8AB99-0AA0	39.9
			GJ		140	150		252						0.4651	2LC0420-8AC99-0AA0	49.8
267-6	6100	3900	GG	110	110	100	177	177	110	17	40.5	102	275	0.3827	2LC0421-0AB99-0AA0	45.9
			GJ		150	160		267						0.6129	2LC0421-0AC99-0AA0	58.1

<sup>1)</sup> To identify complete item numbers specifying the available finish boring options and – if necessary – further order options, please use our configurators on [flender.com](http://flender.com).

↗ For online configuration on [flender.com](http://flender.com), click on the item no.

## Notes

---

- The shaft tolerance must be specified in the order.  
To specify, "-Z" must be added to the article no. and the order codes "Y26" and "Y27" with plain text specification of the shaft tolerance for D1 and D2 must be added as well.
- Jumbo hubs for larger shaft diameters.  
G and J hubs in split clamping hub variant.  
The hub variant with keyway rates as standard. Optionally, the shaft/hub connection can be implemented without keyway as a pure clamping seat.  
For specification of plate pack, see **Page 6/40**.
- Weights and mass moments of inertia apply to the entire coupling with maximum bores D1/D2.

## Ordering example

---

- ARPEX ARF-6 GG coupling, size 132-6
- for shaft diameter  $\varnothing D1$  45h6 mm, without keyway
- for shaft diameter  $\varnothing D2$  50k6 mm,  
with keyway to DIN 6885-1, keyway width P9.

**Article no.:** 2LC0420-2AB99-0AA0-Z L1A+M1C+L45+Y26+Y27

**Plain text to Y26:** h6

**Plain text to Y27:** k6

<sup>1)</sup> To identify complete item numbers specifying the available finish boring options and – if necessary – further order options, please use our configurators on [flender.com](https://www.flender.com).

➤ For online configuration on [flender.com](https://www.flender.com), click on the item no.

# SPARE AND WEAR PARTS

## Plate pack, ARF-6 series

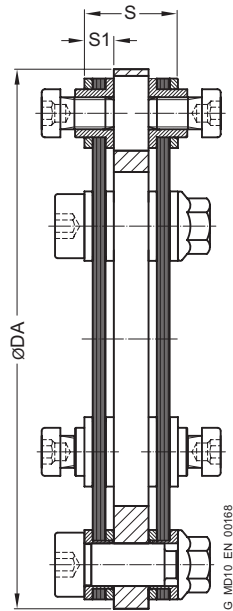
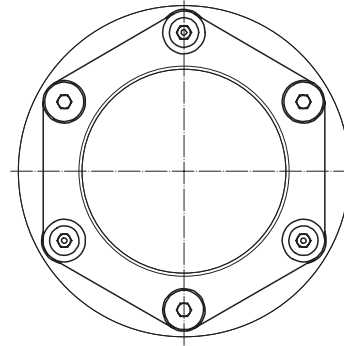

Figure 1



Size DA mm	Type	Dimensions S mm	S1 mm	Mass moment of inertia J kgm <sup>2</sup>	Article No.	Weight m kg
84-6	GG	19	6	0.0003	2LC0420-0AE00-0AA0	0.3
	GJ				2LC0420-0AH00-0AA0	
111-6	GG	19	6	0.0009	2LC0420-1AE00-0AA0	0.46
	GJ				2LC0420-1AH00-0AA0	
132-6	GG	24	8	0.0026	2LC0420-2AE00-0AA0	0.9
	GJ				2LC0420-2AH00-0AA0	
147-6	GG	24	8	0.0038	2LC0420-3AE00-0AA0	1.07
	GJ				2LC0420-3AH00-0AA0	
171-6	GG	29	9	0.0097	2LC0420-4AE00-0AA0	1.96
	GJ				2LC0420-4AH00-0AA0	
182-6	GG	35	11	0.0143	2LC0420-5AE00-0AA0	2.58
	GJ				2LC0420-5AH00-0AA0	
202-6	GG	35	11	0.024	2LC0420-6AE00-0AA0	3.53
	GJ				2LC0420-6AH00-0AA0	
218-6	GG	44	14	0.0383	2LC0420-7AE00-0AA0	4.89
	GJ				2LC0420-7AH00-0AA0	
252-6	GG	54	17	0.0812	2LC0420-8AE00-0AA0	7.9
	GJ				2LC0420-8AH00-0AA0	
267-6	GG	55	17	0.1152	2LC0421-0AE00-0AA0	9.6
	GJ				2LC0421-0AH00-0AA0	

### Note

- Ring plates (Figure 1) are used for the plate packs.
- The plate pack unit for the ARF-6 series is readily available as a spare part in most sizes.
- The plate pack unit comprises two preassembled plate packs with adapter disk, including screw connection. The standard screw connection comprises hexagon socket head cap screws and close-fitting bolts with nuts.





# FLEXIBLE COUPLINGS – N-EUPEX, N-EUPEX DS SERIES

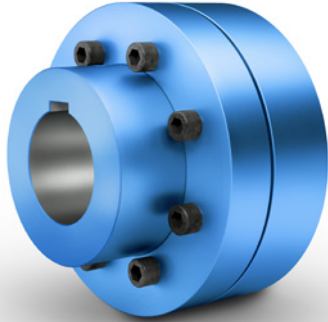

<b>General</b>	<b>7/2</b>
Benefits	7/2
Application	7/2
Design and configurations	7/3
Modular principle of N-EUPEX types	7/5
Technical specifications, N-EUPEX series	7/8
Assignment of N-EUPEX sizes to IEC standard motors	7/10
<b>Type A for easy elastomer flexible replacement</b>	<b>7/11</b>
<b>Type B</b>	<b>7/12</b>
<b>Type B with clamping elements</b>	<b>7/13</b>
<b>Type DK for large misalignment with simple installation and removal</b>	<b>7/14</b>
<b>Type DKS</b>	<b>7/15</b>
<b>Type H</b>	<b>7/16</b>
<b>Type D for easy elastomer flexible replacement</b>	<b>7/18</b>
<b>Type E</b>	<b>7/20</b>
<b>Type P with brake drum</b>	<b>7/22</b>
<b>Type O with brake drum</b>	<b>7/24</b>
<b>Type DBDR with brake disk</b>	<b>7/26</b>
<b>Type ABD with brake disk</b>	<b>7/28</b>
<b>Type ERN with slip unit</b>	<b>7/29</b>
<b>N-EUPEX DS series</b>	<b>7/31</b>
<b>General</b>	<b>7/31</b>
Technical specifications, N-EUPEX DS series	7/31
<b>Type ADS for easy elastomer flexible replacement</b>	<b>7/32</b>
<b>Type BDS</b>	<b>7/33</b>
<b>Type HDS</b>	<b>7/34</b>
<b>Spare and wear parts</b>	<b>7/36</b>



## GENERAL

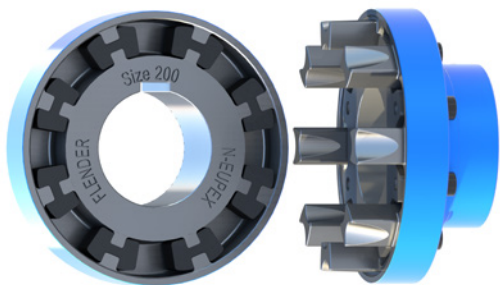

N-EUPEX as overload-holding, fail-safe series

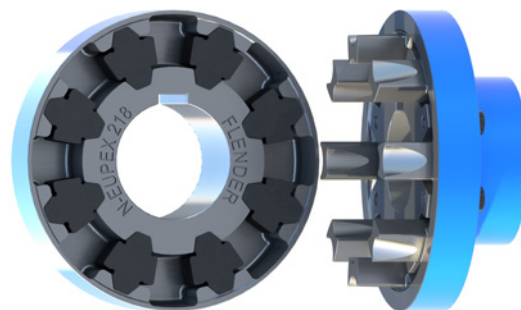

N-EUPEX DS as overload-shedding, non-fail-safe series

N-EUPEX and N-EUPEX DS pin couplings connect machines. They compensate for shaft misalignment, generating only low restorative forces. The torque is conducted through elastomer flexibles, so the coupling has typically flexible rubber properties.

N-EUPEX couplings are overload-holding. By contrast, the N-EUPEX DS series is designed so that overload or advanced wear causes irreparable damage to the elastomer flexibles. The metal parts of N-EUPEX DS couplings can then rotate freely against one another without contact.

### Benefits

N-EUPEX couplings are designed on the modular principle and have a very simple construction. N-EUPEX types are made up of subassemblies to suit requirements. The couplings are assembled by simply fitting the coupling halves together. Wear is restricted to the elastomer flexibles, which must be replaced at the end of their service life.

### Application

The N-EUPEX coupling is available as a catalog standard in 23 sizes with a rated torque of between 28 Nm and 71000 Nm. The coupling is suitable for ambient temperatures of between -30 °C and +80 °C. By using alternative elastomer flexibles, the permissible ambient temperature range can be extended to between -50 °C and +100 °C. Frequently, the coupling is used to connect the motor to the gear unit input shaft. The coupling is suitable especially for drives with uniform to average dynamic loads.



**Coupling suitable for use in potentially explosive atmospheres.**

**Complies with the current ATEX Directive for:**

CE  II 2G Ex h IIC T6 ... T4 Gb X

 II 2D Ex h IIIC T85 °C ... 110 °C Db X

 I M2 Ex h Mb X

Depending on type, the elastomer flexibles can be changed without moving the coupled machines.

The coupling parts are readily available from stock and are mostly finish-machined, i.e. with finished bore, keyway, set screw and balancing.

Examples of applications are pump drives, ventilator drives or crane running gear. Furthermore, N-EUPEX couplings can be used as add-on couplings, particularly on FLUDEX fluid couplings or ARPEX AKR safety couplings. In the case of drives with a diesel engine, N-EUPEX couplings are suitable for driven machines with a low mass moment of inertia. In the case of diesel engine drives, the actual dynamic coupling load should be checked by measurement or torsional vibration calculations.



## Design and configurations

N-EUPEX and N-EUPEX DS couplings consist of two coupling halves mounted on the machine shafts. The coupling parts are connected positively by means of elastomer flexibles. On the two-part variant, the elastomer flexibles can be changed only if one of the coupled machines is moved.

On the three-part variants, the bolted cam ring can be released and moved to enable the flexible to be changed without moving the coupled machines.

### Elastomer flexible of the N-EUPEX series



The flexibles of the N-EUPEX coupling are subjected to compression. This results in progressive torsion spring characteristics. If the flexibles are irreparably damaged, the hub parts come into contact with metal. This causes the torque to continue to be transmitted in "emergency mode" for a short period of time.

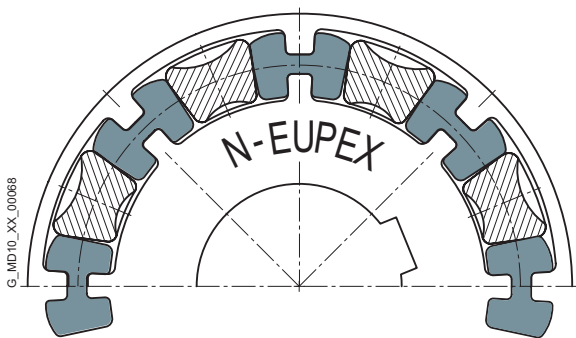

G\_MD10\_XX\_00068

### Elastomer flexible of the N-EUPEX DS series



The flexibles of the N-EUPEX DS series are subjected to compression and bending forces. A linear torsion spring characteristic curve is characteristic in this regard. If the flexibles are irreparably damaged, the metal parts turn against one another without contact, and the power transmission is separated. Fitting new flexibles will make the coupling once more usable. The capacity of the N-EUPEX DS series to shed overloads is especially in demand for highly sensitive machines.

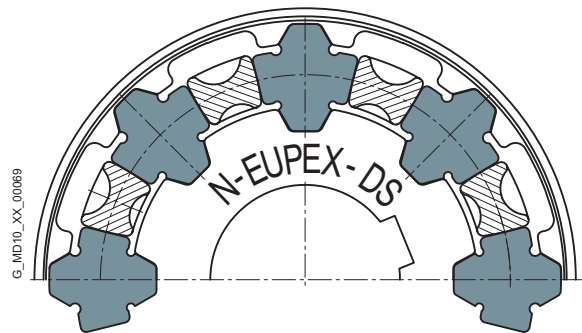

G\_MD10\_XX\_00069

# GENERAL

## Materials

All coupling parts such as cam parts, pocket parts, spacers, hub parts and mounting parts are manufactured from high grade cast iron with lamellar or spheroidal graphite, or from steel. The sleeve pipes of the type DK spacers are made from aluminum.

## Flexible materials

Material/description	Hardness	Marking	Ambient temperature
<b>N-EUPEX series</b>			
<b>NBR standard type</b>	<b>80 ShoreA</b>	<b>Flexible black with blue stripe</b>	<b>-30 °C ... +80 °C</b>
NBR electrically insulating	80 ShoreA	Flexible green	-30 °C ... +80 °C
NBR soft	65 ShoreA	Flexible black with green stripe	-30 °C ... +80 °C
HP (TPU) (size 80 to 280)	97 ShoreA	Flexible blue	-50 °C ... +80 °C
HP (NBR) (size 315 to 710)	90 ShoreA	Flexible black, fabric reinforced	-30 °C ... +80 °C
HP (NBR) (size 58 to 68)	90 ShoreA	Flexible black with magenta stripe	-30 °C ... +80 °C
NBR normal low-backlash	80 ShoreA	Flexible black with yellow stripe	-30 °C ... +80 °C
NBR soft low-backlash	65 ShoreA	Flexible black with white stripe	-30 °C ... +80 °C
NR for low temperature	80 ShoreA	Flexible black with orange stripe	-50 °C ... +50 °C
HNBR high temperature	80 ShoreA	Flexible black with red stripe	-10 °C ... +100 °C
<b>Type N-EUPEX DK/DKS</b>			
HP (TPU) (size 80 to 280)	97 ShoreA	Flexible blue	-50 °C ... +80 °C
HP (NBR) (size 68)	90 ShoreA	Flexible black with magenta stripe	-30 °C ... +80 °C
<b>N-EUPEX DS series</b>			
<b>NBR hard</b>	<b>90 ShoreA</b>	<b>Flexible black</b>	<b>-30 °C ... +80 °C</b>

The technical data do not include the flexible variants NBR low-backlash, HNBR high temperature and NR low temperature. Technical data, prices and article numbers can be found at [www.flender.com](http://www.flender.com)

## Standard types of N-EUPEX and N-EUPEX DS pin coupling

Type	Description
<b>A</b>	Fail-safe, 3-part
<b>B</b>	Fail-safe, 2-part
<b>D</b>	Fail-safe, 3-part, flange variant
<b>E</b>	Fail-safe, 2-part, flange variant
<b>DK</b>	Fail-safe, double-cardanic, with spacer
<b>DKS</b>	Fail-safe, double-cardanic, short length
<b>H</b>	Fail-safe, with adapter
<b>P</b>	Fail-safe, 3-part, with brake drum
<b>O</b>	Fail-safe, 2-part, with brake drum
<b>DBDR</b>	Fail-safe, 3-part, with brake disk, brake disk radially dismountable
<b>ABD</b>	Fail-safe, 3-part, with brake disk
<b>ERN</b>	Fail-safe, 2-part, with slip unit
<b>ADS</b>	Non-fail-safe, 3-part
<b>BDS</b>	Non-fail-safe, 2-part
<b>HDS</b>	Non-fail-safe, with adapter

## Special types of N-EUPEX pin coupling on request

Type	Description
<b>AT</b>	Fail-safe, 3-part, with Taper clamping bush
<b>BT</b>	Fail-safe, 2-part, with Taper clamping bush
<b>F</b>	Fail-safe, 3-part, with intermediate shaft
<b>G</b>	Fail-safe, 2-part, with intermediate shaft
<b>K</b>	Fail-safe, 3-part, with brake drum to customer's requirement
<b>L</b>	Fail-safe, 2-part, with brake drum to customer's requirement
<b>M</b>	Fail-safe, 2-part, with flange dimensions to SAE J620d
<b>DBD</b>	Fail-safe, 3-part, with brake disk
<b>EBD</b>	Fail-safe, 2-part, with brake disk

Further application-related coupling types are available. Dimension sheets for and information on these are available on request.

Modular principle of N-EUPEX types

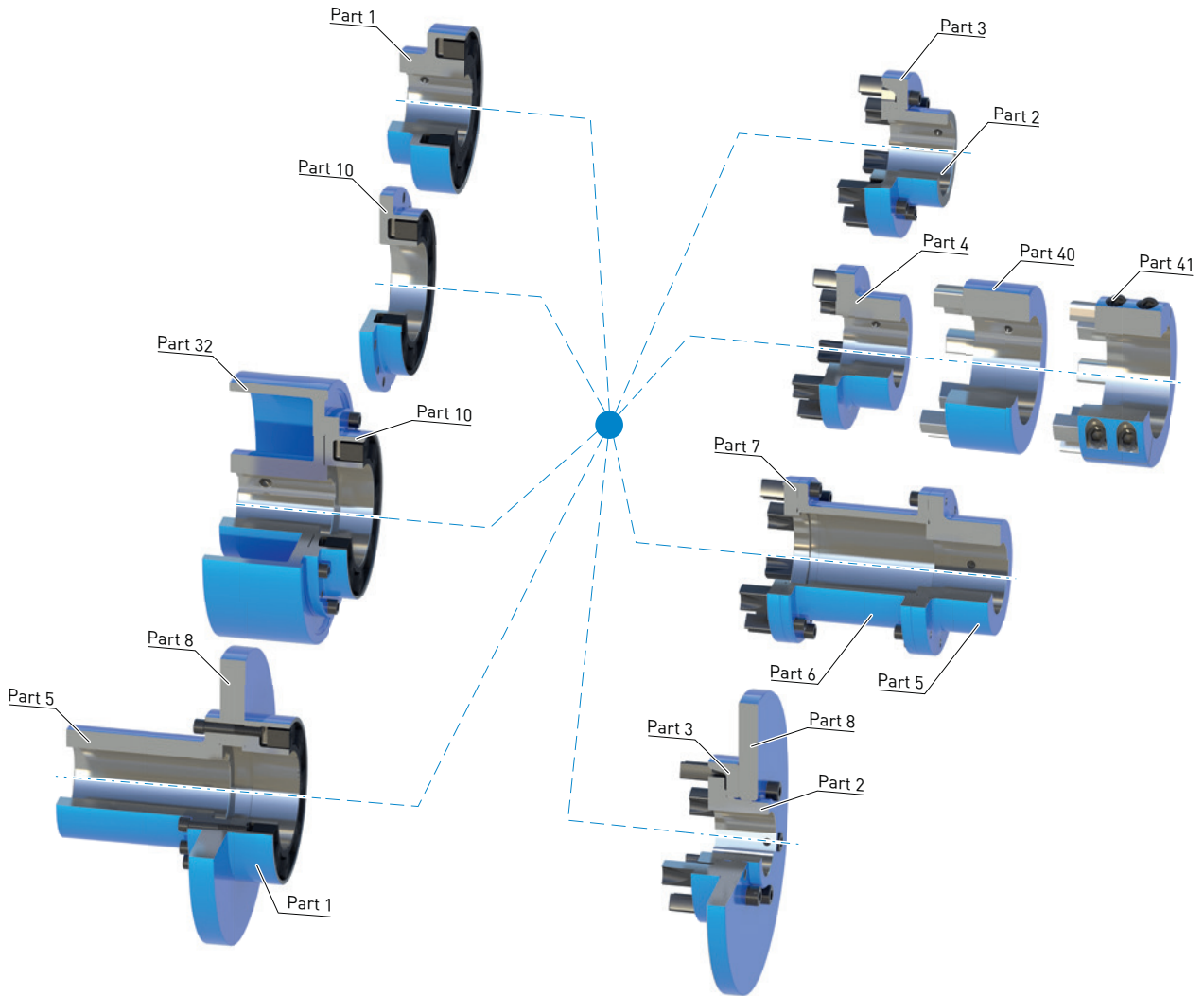

N-EUPEX DK/DKS

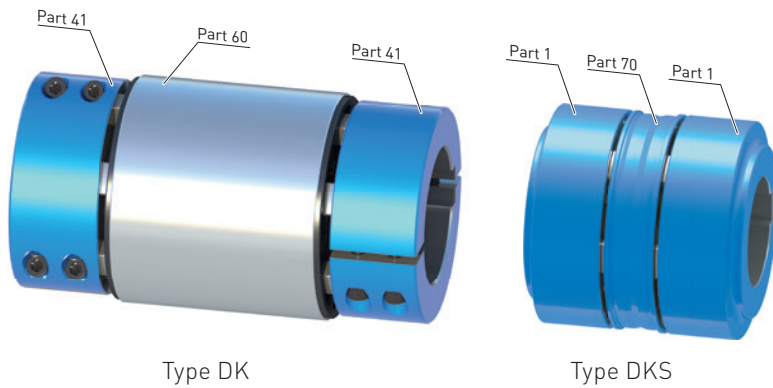

In the case of larger radial misalignment, double-cardanic N-EUPEX couplings can be supplied in addition to the modular system. The spacer (part 60 resp. 70) is centered with the help of the N-EUPEX elastomer elements. Any radial misalignment that emerges between the shaft ends will accordingly be equalized through a corresponding tilt angle in the elastomer joints with this two-joint versions. In the DK version, the separated hubs (part 41) made from steel facilitate simple installation. The DKS version is characterized by a reduced shaft distance.

# GENERAL

## Types N-EUPEX

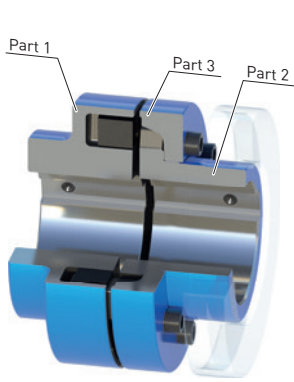

Types A and ADS

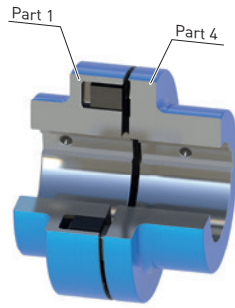

Types B and BDS

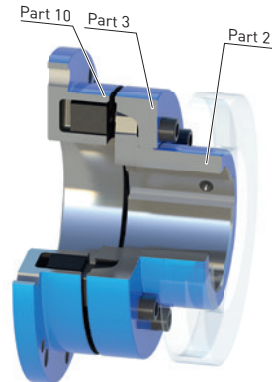

Type D

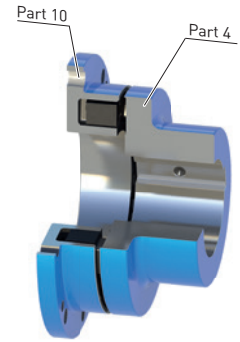

Type E

## Types N-EUPEX with adapter

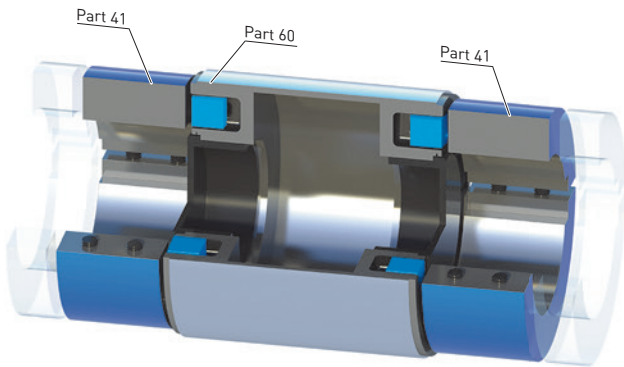

Type DK

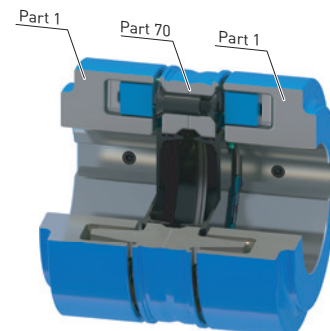

Type DKS

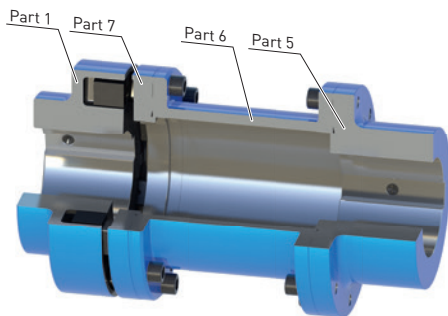

Types H and HDS

Type N-EUPEX with brake disk/brake drum

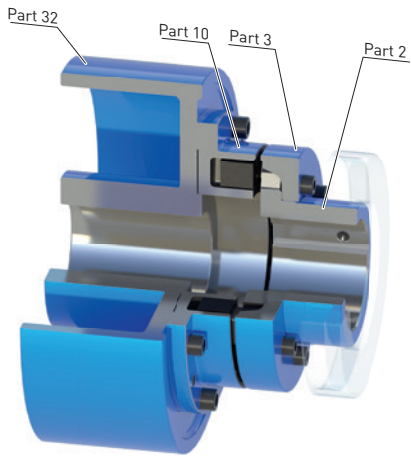

Type P

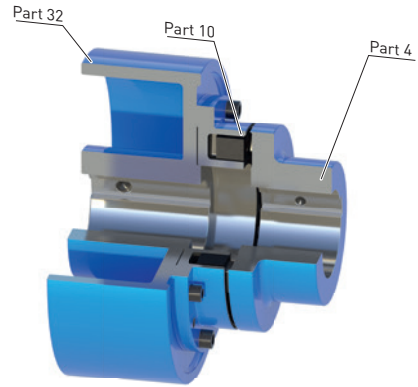

Type O

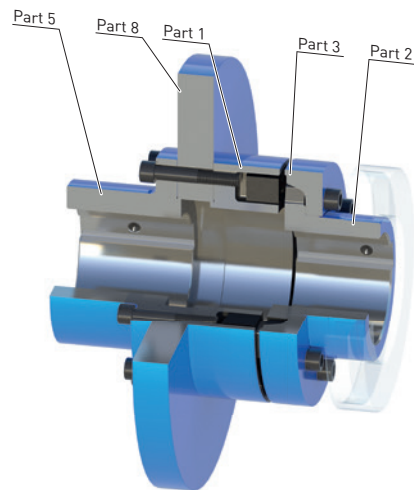

Type DBDR

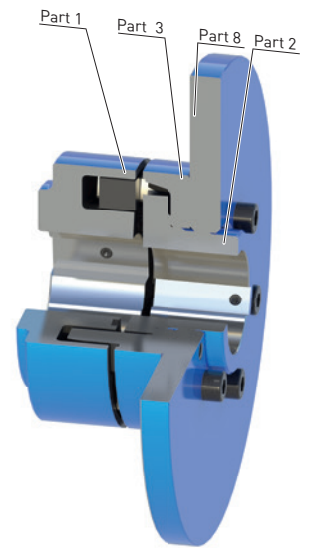

Type ABD

Type N-EUPEX with torque control

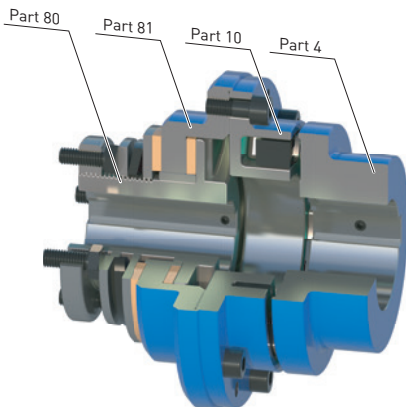

Type ERN

Note

- Further application-specific coupling types are available. Dimension sheets for and information on these are available on request.

# GENERAL

## Technical specifications, N-EUPEX series

Power ratings of the N-EUPEX series (single-joint coupling)										
Size	Rated torque for flexible type			Maximum torque		Torsional stiffness at 50 % capacity utilization for flexible type			Permitted shaft misalignment at speed <sup>1)</sup> n = 1500 rpm	
	65 ShoreA	80 ShoreA	HP <sup>2)</sup>	65 ShoreA	80 ShoreA / HP	65 ShoreA	80 ShoreA	HP	Radial	Angle
	$T_{KN}$	$T_{KN}$	$T_{KN}$	$T_{Kmax}$	$T_{Kmax}$	$C_{Tdyn 50\%}$	$C_{Tdyn 50\%}$	$C_{Tdyn 50\%}$	$\Delta K_r$	$\Delta K_w$
	Nm	Nm	Nm	Nm	Nm	kNm/rad	kNm/rad	kNm/rad	mm	°
58	12	28	34	36	85	0.22	0.75	1,51	0.2	0.15
68	23	48	58	69	145	0.42	1.26	2,79	0.2	0.15
80	40	85	120	120	300	1.13	3.21	14,2	0.2	0.12
95	69	140	200	207	500	1.77	5.32	23,1	0.2	0.12
110	110	225	325	330	812	2.70	8.15	36,1	0.2	0.10
125	165	345	490	495	1225	4.0	12.3	53,6	0.25	0.10
140	250	500	700	750	1750	6.0	18	77,8	0.25	0.10
160	385	840	1200	1150	3000	12.2	39.4	162	0.3	0.10
180	600	1250	1750	1800	4375	20.6	63.6	270	0.3	0.10
200	935	1950	2650	2800	6625	34.2	106.8	426	0.3	0.09
225	1380	2300	3400	4150	8500	52	131	619	0.35	0.09
250	1930	3900	5500	5800	13750	73	221	927	0.35	0.08
280	2700	5500	7400	8100	18500	103	313	1261	0.4	0.08
315	3850	7100	9350	11550	23375	186	472	1130	0.4	0.08
350	5335	10800	13000	16000	32500	255	708	1450	0.5	0.08
400	7150	14000	18000	21450	45000	343	997	2250	0.5	0.08
440	9350	19000	25000	28050	62500	427	1280	3200	0.6	0.08
480	11550	25100	33000	34650	82500	550	1781	4100	0.6	0.07
520	14630	32400	42000	43890	105000	650	2124	4800	0.65	0.07
560	20130	39000	50600	60390	126500	1095	3119	7600	0.65	0.07
610	26400	49000	63800	79200	159500	1422	3873	9400	0.75	0.07
660	33990	63000	79000	101970	197500	1799	4834	11300	0.8	0.07
710	42900	71000	93500	128700	233750	2339	5608	13400	0.9	0.07

For coupling fatigue torque:  
 $T_{KW} = 0,15 \cdot T_{KN}$ , where  $T_N > T_W$  must be adhered to.

### N-EUPEX shaft distance S and radial misalignment $\Delta K_r$

**N-EUPEX (single-joint coupling)**  
 Radial misalignment  $\Delta K_r$  and angular misalignment  $\Delta K_w$  as well as changes in gap dimension are equalized in a elastomer joint. Values for  $\Delta S$  can be found in the respective type selection tables.

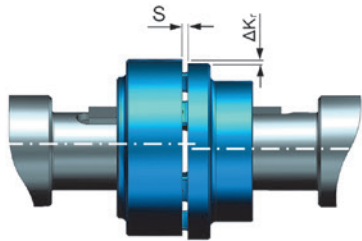

**N-EUPEX DK/DKS (two-joint coupling)**  
 Radial misalignment  $\Delta K_r$  and angular misalignment  $\Delta K_w$  as well as changes in gap dimension are equalized in two elastomer joints. Values for  $\Delta S$  can be found in the corresponding type selection tables.

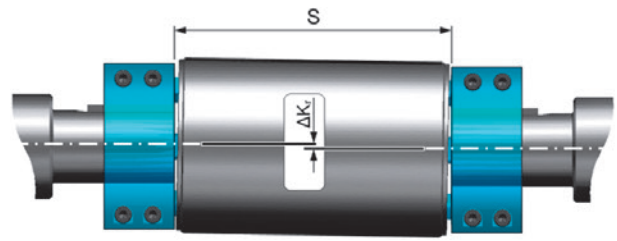

<sup>1)</sup> The maximum speed for the respective type must be noted. For additional information on the allowable shaft misalignment, please refer to the operating instructions.

<sup>2)</sup> For sizes 80 to 280, in case of higher temperatures the temperature factor FT according to the table on page E/19 in the Introduction has to be considered.

Performance data for type N-EUPEX DK (two-joint coupling)										
Size	Rated torque	Maximum torque	Torsional stiffness at 50 % capacity utilization for flexible type HP $C_{Tdyn\ 50\%}$ kNm/rad	Permitted shaft misalignment <sup>1)</sup> at $n = 1500$ rpm					Type DKS $\Delta K_r$ mm	Angle <sup>2)</sup> $\Delta K_w$ °
	HP $T_{KN}$ Nm	HP $T_{Kmax}$ Nm		Radial Type DK						
				S=100 mm $\Delta K_{r\ 100}$ mm	S=140 mm $\Delta K_{r\ 140}$ mm	S=180 mm $\Delta K_{r\ 180}$ mm	S=200 mm $\Delta K_{r\ 200}$ mm	S=250 mm $\Delta K_{r\ 250}$ mm		
68	48	120	1.18	1.2	-	-	-	-	-	0.15
80	85	212	5.6	1.2	1.7	-	-	-	0.5	0.12
95	140	350	9	1.1	1.6	-	-	-	0.5	0.12
110	225	562	14	1.1	1.5	2.1	-	-	0.6	0.10
125	345	862	21	1.0	1.5	2.0	2.3	-	0.6	0.10
140	500	1250	31	1.0	1.4	1.8	2.1	2.7	0.7	0.10
160	840	2100	63	-	1.3	1.8	2.1	2.7	0.7	0.10
180	1250	3125	107	-	1.3	1.8	2.0	2.6	0.7	0.10
200	1950	4875	170	-	1.2	1.7	2.0	2.6	0.8	0.09
225	2300	5750	240	-	-	1.7	1.9	2.6	0.9	0.09
250	3900	9750	370	-	-	-	-	-	1.1	0.08
280	5500	13750	525	-	-	-	-	-	1.1	0.08

For coupling fatigue torque:  
 $T_{KW} = 0,15 \cdot T_{KN}$ , where  $T_N > T_W$  must be adhered to.

**Torsional stiffness and damping  
 (single-joint or two-joint coupling)**

The values stated in the above table apply to a capacity utilization of 50 %, an excitation amplitude of 10 %  $T_{KN}$  with frequency 10 Hz and an ambient temperature of 20 °C. The dynamic torsional stiffness is load-dependent and increases in proportion to capacity utilization. The following table shows the correction factors for different rated loads.

$C_{Tdyn} = C_{Tdyn\ 50\%} \cdot FKC$

	Load $T_N / T_{KN}$						
	20 %	40 %	50 %	60 %	70 %	80 %	100 %
Correction factor FKC							
65/80 ShoreA HP (size 58-68, 315-710)	0,50	0,82	1,00	1,20	1,40	1,63	2,10
HP (size 80 - 280)	0,55	0,85	1,00	1,14	1,29	1,42	1,69

**The damping coefficient is  $\Psi = 1.4$  for the 65/80 ShoreA packages and  $\Psi = 1.2$  for the HP package**

Furthermore, torsional stiffness and damping depend on the ambient temperature, on the frequency and on the amplitude of the torsional vibration excitation. More precise torsional stiffness and damping parameters on request.

Due to the manufacturing process and ageing of the elastomers, the tolerance for the dynamic stiffness is  $\pm 20\%$ .

**Permitted shaft misalignment  
 (single-joint or two-joint coupling)**

The permitted shaft misalignment depends on the operating speed. As the speed increases, lower shaft misalignment values are permitted. The correction factors for different speeds are specified in the following table. The maximum speed for the respective coupling size must be noted!

$\Delta K_{perm} = \Delta K_{1500} \cdot FKV$

	Speed in rpm			
	500	1000	1500	3000
Correction factor FKV	1.7	1.2	1.0	0.7

For fitting, the maximum gap dimension of  $S_{max.} = S + \Delta S$  and the minimum gap dimension of  $S_{min.} = S - \Delta S$  are permitted.

Shaft misalignments  $\Delta K_r$  and  $\Delta K_w$  may occur simultaneously.

<sup>1)</sup> The maximum speed for the respective type must be noted. For additional information on the allowable shaft misalignment, please refer to the operating instructions.  
<sup>2)</sup> The angular misalignment  $\Delta K_w$  refers to the maximum additional tilting of the shaft axes.

# GENERAL

## Assignment of N-EUPEX sizes to IEC standard motors (selected operating factor = 1.25) <sup>1)</sup>

Three-phase motor Size	Output at ≈ 3000 rpm		Output at ≈ 1500 rpm		Output at ≈ 1000 rpm		Output at ≈ 750 rpm		DE (ASI) shaft end D x E acc. to IEC	
	$P_M$ kW	N-EUPEX size	$P_M$ kW	N-EUPEX size	$P_M$ kW	N-EUPEX size	$P_M$ kW	N-EUPEX size	D mm	E mm
56	0.09	58	0.06	58					9	20
56	0.12	58	0.09	58					9	20
63	0.18	58	0.12	58					11	23
63	0.25	58	0.18	58					11	23
71	0.37	58	0.25	58					14	30
71	0.55	58	0.37	58					14	30
80	0.75	58	0.55	58	0.37	58			19	40
80	1.1	58	0.75	58	0.55	58			19	40
90 S	1.5	58	1.1	58	0.75	58			24	50
90 L	2.2	58	1.5	58	1.1	58			24	50
100 L	3	68	2.2	68	1.5	68	0.75	68	28	60
100 L			3	68			1.1	68	28	60
112 M	4	68	4	68	2.2	68	1.5	68	28	60
132 S	5.5	80	5.5	80	3	80	2.2	80	38	80
132 S	7.5	80							38	80
132 M			7.5	80	4	80	3	80	38	80
132 M					5.5	80			38	80
160 M	11	80	11	95	7.5	95	4	80	42	110
160 M	15	80					5.5	95	42	110
160 L	18.5	80	15	95	11	95	7.5	95	42	110
180 M	22	95	18.5	110					48	110
180 L			22	110	15	110	11	110	48	110
200 L	30	110	30	125	18.5	110	15	125	55	110
200 L	37	110			22	125			55	110
225 S									55	110
225 S			37	125			18.5	125	60	140
225 M	45	110							55	110
225 M			45	140	30	140	22	140	60	140
250 M	55	125							60	140
250 M			55	140	37	140	30	140	65	140
280 S	75	140							65	140
280 S			75	180	45	180	37	180	75	140
280 M	90	140							65	140
280 M			90	180	55	180	45	180	75	140
315 S	110	140							65	140
315 S			110	180	75	180	55	180	80	170
315 M	132	160							65	140
315 M			132	180	90	180	75	180	80	170
315 L	160	160							65	140
315 L	200	160							65	140
315 L			160	200	110	200	90	200	80	170
315 L			200	200	132	200	110	200	80	170
315 L					160	200	132	225	85	170
315	250	180							65	140
315	315	200							65	140
315			250	225	200	250			85	170
355	355	200							75	140
355	400	200							75	140
355	500	225							75	140

<sup>1)</sup> Outputs  $P_M$  of IEC motors and assigned N-EUPEX couplings (80 ShoreA)



# TYPE A

for easy elastomer flexible replacement

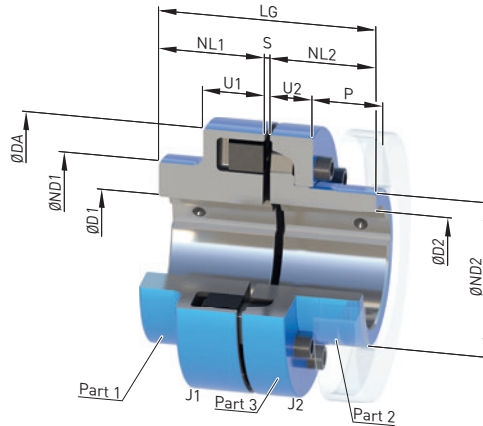

Size	Rated torque flexible type 80 ShoreA $T_{KN}$ Nm	Speed $n_{Kmax}$ rpm	Dimensions in mm Bore with keyway to DIN 6885-1														Mass moment of inertia $J_1/J_2$ kgm <sup>2</sup>	Article no. <sup>1)</sup>	Weight $m$ kg
			D1		D2		DA	ND1 <sup>2)</sup>	ND2	NL1/NL2	S	$\Delta S$ +/-	U1	U2	P	LG			
110	225	6300	-	55	-	45	110	86	60.5	40	3	1.0	34	20	33	83	0.002	2LC0170-4AB	2.7
125	345	6100	-	60	-	55	125	100	73.5	50	3	1.0	36	23	38	103	0.004	2LC0170-5AB	4.2
140	500	5800	-	65	-	60	140	100	80.5	55	3	1.0	34	28	43	113	0.007	2LC0170-6AB	5.6
160	840	5100	-	70	-	70	160	108	93.5	60	4	2.0	39	28	47	124	0.013	2LC0170-7AB	7.8
180	1250	4500	-	80	-	80	180	125	106	70	4	2.0	42	30	50	144	0.023	2LC0170-8AB	11
200	1950	4000	-	85	-	90	200	140	119	80	4	2.0	47	32	53	164	0.04	2LC0171-0AB	16
225	2300	3600	-	90	-	100	225	150	135	90	4	2.0	52	38	61	184	0.07	2LC0171-1AB	23
250	3900	3300	46	100	-	115	250	165	153	100	5.5	2.5	60	42	69	205.5	0.13	2LC0171-2AB	32
280	5500	3000	49	110	54	125	280	180	168	110	5.5	2.5	65	42	73	225.5	0.20	2LC0171-3AB	42
315	7100	2600	49	120	45	145	315	200	196	125	5.5	2.5	70	47	78	255.5	0.37	2LC0171-4AB	61
350	10800	2400	61	140	60	165	350	230	226	140	5.5	2.5	74	51	83	285.5	0.64	2LC0171-5AB	85
400	14000	2000	66	150	65	180	400	250	246	160	5.5	2.5	78	56	88	325.5	1.1	2LC0171-6AB	119
440	19000	1900	80	160	80	190	440	265	261	180	7.5	2.5	86	64	99	367.5	1.7	2LC0171-7AB	156
480	25100	1800	90	180	90	215	480	300	296	190	7.5	2.5	90	65	104	387.5	2.7	2LC0171-8AB	199
520	32400	1500	100	190	100	225	520	315	310	210	7.5	2.5	102	68	115	427.5	3.8	2LC0172-0AB	251
560	39000	1500	120	200	120	230	560	320	316	220	9	3.0	115	80	125	449	5.3	2LC0172-1AB	303
610	49000	1300	130	220	130	250	610	352	348	240	9	3.0	121	88	135	489	8.2	2LC0172-2AB	393
660	63000	1200	140	240	140	275	660	384	380	260	9	3.0	132	96	145	529	12.3	2LC0172-3AB	501
710	71000	1100	140	260	140	300	710	416	412	290	9	3.0	138	102	155	589	17.4	2LC0172-4AB	623

### Configurable variants <sup>1)</sup>

- ØD1 Without finished bore  
With finished bore
- ØD2 Without finished bore  
With finished bore

### Notes

- Weights and mass moments of inertia apply to maximum bores.

### Ordering example

- N-EUPEX A coupling, size 200
- Part 1: Bore D1 65H7 mm, keyway to DIN 6885-1 and set screw
- Part 2: Bore D2 50H7 mm, keyway to DIN 6885-1 and set screw

Article no.: 2LC0171-0AB99-0AA0 L1F+M1C

<sup>1)</sup> To identify complete item numbers specifying the available finish boring options and – if necessary – further order options, please use our configurators on [fletcher.com](http://fletcher.com).

<sup>2)</sup> The hub diameter HD1 can be smaller for small bores.

➤ For online configuration on [fletcher.com](http://fletcher.com), click on the item no.

# TYPE B

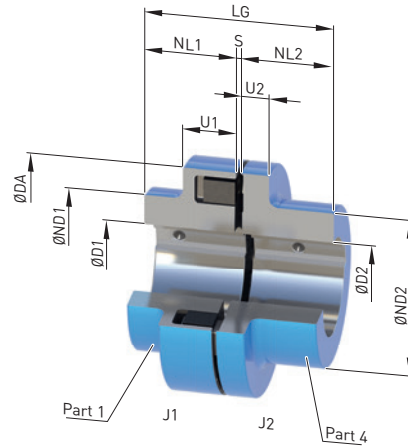

7

Size	Rated torque flexible type 80 ShoreA $T_{KN}$ Nm	Speed $n_{Kmax}$ rpm	Dimensions in mm Bore with keyway to DIN 6885-1											Mass moment of inertia $J_1/J_2$ kgm <sup>2</sup>	Article no. <sup>1)</sup>	Weight $m$ kg			
			D1		D2		Part 40 <sup>2)</sup>			DA	ND1	ND2	NL1/NL2				S	ΔS	U1
			min.	max.	min.	max.	max.							±					
58	28	9000	-	22	-	25	32	58	58	40	20	3	1.0	20	8	43	0.0001	2LC0170-0AA	0.4
68	48	8400	-	28	-	30	40	68	68	50	20	3	1.0	20	8	43	0.0002	2LC0170-1AA	0.6
80	85	7200	-	38	-	42	48	80	80	68	30	3	1.0	30	10	63	0.0006	2LC0170-2AA	1.3
95	140	6600	-	48	-	48	60	95	76	76	35	3	1.0	30	12	73	0.0012	2LC0170-3AA	1.8
110	225	6300	-	55	-	55	70	110	86	86	40	3	1.0	34	14	83	0.0024	2LC0170-4AA	2.8
125	345	6100	-	60	-	60	82	125	100	100	50	3	1.0	36	18	103	0.005	2LC0170-5AA	4.7
140	500	5800	-	65	-	65	90	140	100	100	55	3	1.0	34	20	113	0.007	2LC0170-6AA	5.7
160	840	5100	-	70	-	70	105	160	108	108	60	4	2.0	39	20	124	0.01	2LC0170-7AA	7.8
180	1250	4500	-	80	-	80	120	180	125	125	70	4	2.0	42	20	144	0.02	2LC0170-8AA	12
200	1950	4000	-	85	-	85	130	200	140	140	80	4	2.0	47	24	164	0.04	2LC0171-0AA	17
225	2300	3600	-	90	-	90	150	225	150	150	90	4	2.0	52	18	184	0.06	2LC0171-1AA	23
250	3900	3300	46	100	46	100	170	250	165	165	100	5.5	2.5	60	18	205.5	0.11	2LC0171-2AA	30
280	5500	3000	49	110	54	110	190	280	180	180	110	5.5	2.5	65	20	225.5	0.18	2LC0171-3AA	41

### Configurable variants <sup>1)</sup>

- ØD1 Without finished bore  
With finished bore
- ØD2 Without finished bore  
With finished bore

### Notes

- Weights and mass moments of inertia apply to maximum bores.

### Ordering example

- N-EUPEX B coupling, size 95
- Part 1: Bore D1 42H7 mm, keyway to DIN 6885-1 and set screw
- Part 2: Bore D2 32H7 mm, keyway to DIN 6885-1 and set screw

Article no.: 2LC0170-3AA99-0AA0 L0X+M0T

<sup>1)</sup> To identify complete item numbers specifying the available finish boring options and – if necessary – further order options, please use our configurators on [flender.com](http://flender.com).

<sup>2)</sup> Version with part 40 (jumbo hub) available on request.

➤ For online configuration on [flender.com](http://flender.com), click on the item no.

# TYPE B

with clamping elements

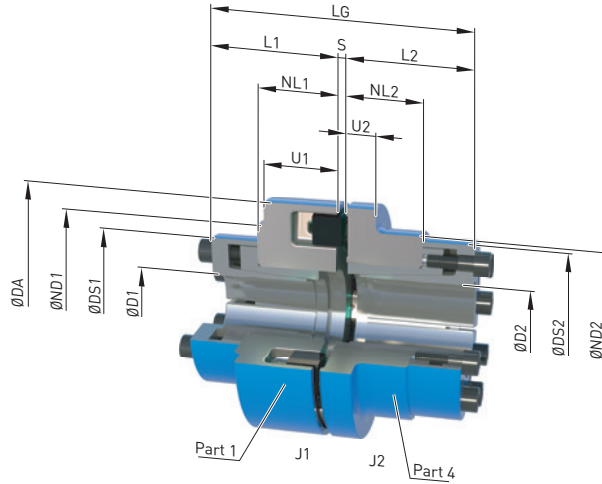

Size	Rated torque <sup>2)</sup> flexible type 80 ShoreA $T_{KN}$ Nm	Speed $n_{Kmax}$ rpm	Dimensions in mm														Mass moment of inertia		Article no. <sup>1)</sup>	Weight $m$ kg
			D1 max.	D2 max.	DA	ND1	ND2	NL1	NL2	S	$\Delta S$ +/-	DS1	DS2	L1	L2	LG	$J_1$ kgm <sup>2</sup>	$J_2$ kgm <sup>2</sup>		
80	85	7200	25	30	80	80	68	30	26	3	1.0	56	62	50	46	99	0.0007	0.0011	2LC0170-2BF	2.0
95	140	6600	30	38	95	95	76	30	31	3	1.0	62	72	50	51	104	0.0013	0.0012	2LC0170-3BF	2.7
110	225	6300	38	40	110	88	86	35	31	3	1.0	72	75	55	51	109	0.0027	0.0035	2LC0170-4BF	3.8
125	345	6100	40	48	125	125	100	35	46	3	1.0	75	87	55	71	129	0.0046	0.0062	2LC0170-5BF	5.9
140	500	5800	40	48	140	101	100	39	46	3	1.0	75	87	59	71	133	0.0067	0.0089	2LC0170-6BF	7.1
160	840	5100	55	55	160	108	108	52	52	4	2.0	98	98	77	77	158	0.013	0.014	2LC0170-7BF	10
180	1250	4500	65	65	180	125	125	52	52	4	2.0	111	111	77	77	158	0.021	0.024	2LC0170-8BF	13
200	1950	4000	70	75	200	140	140	62	62	4	2.0	119	126	93	93	190	0.039	0.047	2LC0171-0BF	19
225	2300	3600	75	75	225	150	150	63	63	4	2.0	126	126	94	94	192	0.064	0.063	2LC0171-1BF	24
250	3900	3300	85	85	250	165	165	70	70	5.5	2.5	137	137	101	101	207.5	0.11	0.10	2LC0171-2BF	32
280	5500	3000	85	85	280	180	180	77	77	5.5	2.5	137	137	108	108	221.5	0.18	0.16	2LC0171-3BF	43

### Configurable variants<sup>1)</sup>

- ØD1 with clamping element
- ØD2 with clamping element

### Notes

- For dimensions U1 and U2, see type B on page 7/12.
- Weights and mass moments of inertia apply to maximum bores.
- Recommended shaft tolerances h8 to m6

### Ordering example

- N-EUPEX B coupling with clamping element, size 95
- Part 1: Bore D1 30 mm  
recommended shaft tolerances h8 to m6
- Part 4: Bore D2 38 mm  
recommended shaft tolerances h8 to m6

Article no.: 2LC0170-3BF99-0AA0 L0S+M0V

<sup>1)</sup> To identify complete item numbers specifying the available size of the clamping element and – if necessary – further order options, please use our configurators on [flender.com](http://flender.com).

<sup>2)</sup> If clamping elements are used, their maximum permissible torques must be observed. The relevant information can be consulted through our configurators on [flender.com](http://flender.com).

➤ For online configuration on [flender.com](http://flender.com), click on the item no.

# TYPE DK

for large misalignment with simple installation and removal

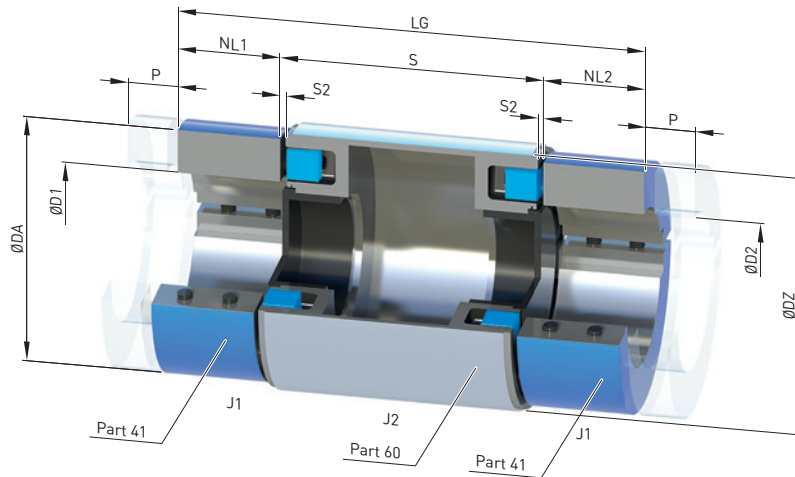

Size	Rated torque flexible type HP $T_{KN}$	Speed $n_{Kmax}$	Dimensions in mm											Mass moment of inertia		Article no. <sup>1)</sup>	Weight $m$
			Bore with keyway to DIN 6885-1		DA	DZ	NL1/NL2	Shaft distances $S$ <sup>2)</sup>		$\Delta S$	S2	P	LG	$J_1$	$J_2$		
			D1/D2	min.				max.	Preferred dimension								
68	48	5500	20	40	68	70	30	100		1	2	15	160	0.0004	0.0003	2LC0170-1BA	1.66
80	85	5300	25	48	80	86	34	100	140	1	2	16	168	0.001	0.001	2LC0170-2BA	2.64
95	140	5100	25	60	95	100	40	100	140	1	2	18	180	0.002	0.002	2LC0170-3BA	4.0
110	225	4800	30	70	110	120	45	100	140, 180	1	2	21	190	0.004	0.005	2LC0170-4BA	6.0
125	345	4600	30	82	125	130	50	140	100, 180, 200	1	2.5	24	240	0.008	0.007	2LC0170-5BA	8.2
140	500	4400	40	90	140	150	54	140	100, 180, 200, 250	1	2.5	26	248	0.013	0.014	2LC0170-6BA	11.8
160	840	4000	40	105	160	170	70	140	180, 200, 250	1.5	3	30	280	0.030	0.024	2LC0170-7BA	18.3
180	1250	3700	40	120	180	190	75	180	140, 200, 250	1.5	3	32	330	0.051	0.043	2LC0170-8BA	24.8
200	1950	3400	45	130	200	210	80	180	140, 200, 250	1.5	3.5	35	340	0.085	0.069	2LC0171-0BA	33.7
225	2300	3000	45	150	225	240	90	180	200, 250	1.5	3.5	39	360	0.152	0.123	2LC0171-1BA	46.9

## Configurable variants <sup>1)</sup>

- ØD1 With finished bore
- ØD2 With finished bore

## Notes

- The total length, weight and mass moments of inertia apply to maximal bores and shaft distances according to the preferred dimension.
- Recommended shaft tolerances  $j_6$  to  $p_6$
- A combination of part 60 with other cam parts as part 41 is not permitted.

## Ordering example

- N-EUPEX DK coupling, size 95,  $S = 100$  mm
- Part 41-1: Bore D1 42 mm, with keyway as per DIN 6885-1, recommended shaft tolerances  $j_6$  to  $p_6$
- Part 41-2: Bore D1 32 mm, with keyway as per DIN 6885-1, recommended shaft tolerances  $j_6$  to  $p_6$

Article no.: 2LC0170-3BA99-0AA0 L0X+M0T

<sup>1)</sup> To identify complete item numbers specifying the available finish boring options and – if necessary – further order options, please use our configurators on [flender.com](http://flender.com).

<sup>2)</sup> Special lengths on request.

➤ For online configuration on [flender.com](http://flender.com), click on the item no.

# TYPE DKS

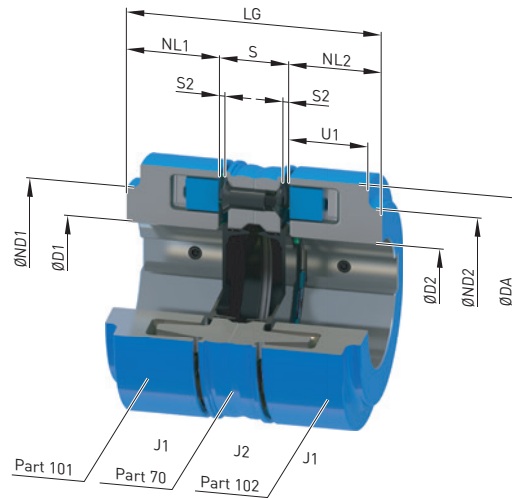

Size	Rated torque flexible type HP $T_{KN}$ Nm	Speed $n_{Kmax}$ rpm	Dimensions in mm										Mass moment of inertia		Article no. <sup>1)</sup>	Weight $m$ kg	
			Bore with keyway to DIN 6885-1 D1/D2		DA	ND1/ND2	NL1/NL2	S	$\Delta S$ +/-	S2	U1	LG	$J_1$ kgm <sup>2</sup>	$J_2$ kgm <sup>2</sup>			
			min.	max.													
80	85	5300	-	38	80	80	30	26	1.0	2	30	86	0.0006	0.0007	2LC0170-2BD	1.8	
95	140	5100	-	48	95	76	35	26	1.0	2	30	96	0.0012	0.0013	2LC0170-3BD	2.6	
110	225	4800	-	55	110	86	40	28	1.0	2	34	108	0.0024	0.0025	2LC0170-4BD	4.0	
125	345	4600	-	60	125	100	50	29	1.0	2.5	36	129	0.005	0.004	2LC0170-5BD	5.9	
140	500	4400	-	65	140	100	55	35	1.0	2.5	34	145	0.006	0.008	2LC0170-6BD	7.6	
160	840	4000	-	70	160	108	60	36	1.5	3	39	156	0.012	0.014	2LC0170-7BD	11	
180	1250	3700	-	80	180	125	70	36	1.5	3	42	176	0.021	0.023	2LC0170-8BD	15	
200	1950	3400	-	85	200	140	80	41	1.5	3.5	47	201	0.038	0.040	2LC0171-0BD	22	
225	2300	3000	-	90	225	150	90	41	1.5	3.5	52	221	0.065	0.070	2LC0171-1BD	31	
250	3900	2600	46	100	250	165	100	54	2.0	4	60	254	0.11	0.14	2LC0171-2BD	44	
280	5500	2400	49	110	280	180	110	54	2.0	4	65	274	0.19	0.21	2LC0171-3BD	58	

### Configurable variants <sup>1)</sup>

- ØD1 Without finished bore  
With finished bore
- ØD2 Without finished bore  
With finished bore

### Notes

- The total length, weight and mass moments of inertia apply to maximal bores and shaft distances according to the preferred dimension.

### Ordering example

- N-EUPEX DKS coupling, size 95
- Part 1-01: Bore D1 42H7 mm, with keyway as per DIN 6885-1 and set screw
- Part 1-02: Bore D2 32H7 mm, with keyway as per DIN 6885-1 and set screw

Article no.: 2LC0170-3BD99-0AA0 L0X+M0T

<sup>1)</sup> To identify complete item numbers specifying the available finish boring options and – if necessary – further order options, please use our configurators on [flender.com](http://flender.com).

➤ For online configuration on [flender.com](http://flender.com), click on the item no.

# TYPE H

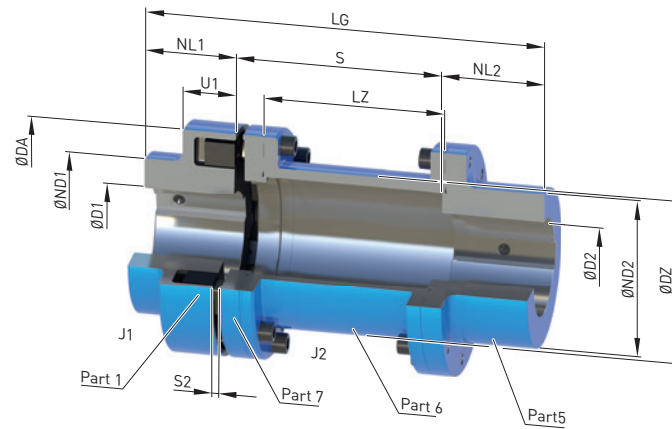

Size	Rated torque flexible type 80 ShoreA $T_{KN}$ Nm	Speed $n_{Kmax}$ rpm	Dimensions in mm														Mass moment of inertia		Article no. <sup>1)</sup>	Weight $m$ kg		
			Bore with keyway to DIN 6885-1				DA	ND1 <sup>2)</sup>	ND2	NL1	NL2	S	S2	LZ	DZ	LG	$J_1$ kgm <sup>2</sup>	$J_2$ kgm <sup>2</sup>				
D1 min.	D1 max.	D2 min.	D2 max.																			
80	85	7200	-	38	-	38 <sup>3)</sup>	80	80	55	30	45	100	5	87	51	175	0.0006	0.001	2LC0170-2AG	2.4		
												140		127		215		0.001		2LC0170-2AG	2.5	
95	140	6600	-	48	-	48 <sup>3)</sup>	95	76	70	35	45	100	5	87	63	180	0.0009	0.003	2LC0170-3AG	3.3		
												140		127		220		0.003		2LC0170-3AG	3.6	
110	225	6300	-	55	-	55 <sup>3)</sup>	110	86	80	40	50	100	85	73	190	0.003	0.005	2LC0170-4AG	4.8			
											50		140		5		125		230	0.006	2LC0170-4AG	5.0
125	345	6100	-	60	-	60 <sup>3)</sup>	125	100	90	50	50	5	125	85	240	0.005	0.01	2LC0170-5AG	6.9			
											60		180		165		280		0.006	2LC0170-4AG	5.6	
											50		100		85		200		0.01	2LC0170-5AG	7.4	
											50		140		125		240		0.01	2LC0170-5AG	7.4	
											60		180		165		290		0.011	2LC0170-5AG	7.8	
70	200	185	320	0.012	2LC0170-5AG	8.1																
80	250	235	380	0.012	2LC0170-5AG	8.6																
140	500	5800	-	65	-	65 <sup>3)</sup>	140	100	100	55	65	100	82	91	220	0.007	0.018	2LC0170-6AG	9.6			
											65		140		122		260		0.019	2LC0170-6AG	10.1	
											65		180		5		162		300	0.02	2LC0170-6AG	10.6
											65		200		182		320		0.021	2LC0170-6AG	10.9	
80	250	232	385	0.022	2LC0170-6AG	11.5																

### Configurable variants <sup>1)</sup>

- ØD1 Without finished bore  
With finished bore
- ØD2 Without finished bore  
With finished bore

<sup>1)</sup> To identify complete item numbers specifying the available finish boring options and – if necessary – further order options, please use our configurators on [flender.com](http://flender.com).

<sup>2)</sup> The hub diameter HD1 can be smaller for small bores.

<sup>3)</sup> For bore diameters greater than the following values, the feather key must be at least 3 mm behind the shaft end. Gr. 80 D2 > 32 mm; Gr. 95 D2 > 42 mm; Gr. 110 D2 > 50 mm; Gr. 125 D2 > 59 mm; Gr. 140 D2 > 64 mm.

➤ For online configuration on [flender.com](http://flender.com), click on the item no.

Size	Rated torque flexible type 80 ShoreA $T_{KN}$ Nm	Speed $n_{Kmax}$ rpm	Dimensions in mm													Mass moment of inertia		Article no. <sup>1)</sup>	Weight $m$ kg	
			Bore with keyway to DIN 6885-1				DA	ND1 <sup>2)</sup>	ND2	NL1	NL2	S	S2	LZ	DZ	LG	$J_1$ kgm <sup>2</sup>			$J_2$ kgm <sup>2</sup>
D1	D2																			
min.	max.	min.	max.																	
160	840	5100	-	70	-	70	160	108	108	60	70	100	81.5	230	0.013	0.03	2LC0170-7AG	12.5		
																	0.032	2LC0170-7AG	13	
																	0.034	2LC0170-7AG	14	
																	0.035	2LC0170-7AG	14	
180	1250	4500	-	80	-	80	180	125	125	70	80	140	121.5	270	0.023	0.053	2LC0170-8AG	18		
																	0.057	2LC0170-8AG	19	
																	0.059	2LC0170-8AG	20	
																	0.064	2LC0170-8AG	21	
200	1950	4000	-	85	-	90	200	140	140	80	90	180	158.5	350	0.04	0.094	2LC0171-0AG	25		
																	0.099	2LC0171-0AG	26	
																	0.104	2LC0171-0AG	27	
																	0.109	2LC0171-0AG	28	
225	2300	3600	-	90	-	100	225	150	150	90	100	180	158.5	370	0.07	0.157	2LC0171-1AG	33		
																	0.16	2LC0171-1AG	34	
																	0.17	2LC0171-1AG	35	
																	0.18	2LC0171-1AG	37	
250	3900	3300	46	100	46	110	250	165	165	100	110	200	172.5	185	0.12	0.27	2LC0171-2AG	48		
																	0.28	2LC0171-2AG	50	
																	0.3	2LC0171-2AG	52	
280	5500	3000	49	110	51	130	280	180	180	110	120	250	8	222.5	215	480	0.20	0.51	2LC0171-3AG	67
315	7100	2600	49	120	51	140	315	200	200	125	140	250	8	222.5	246	515	0.35	0.85	2LC0171-4AG	96
350	10800	2400	61	140	51	160	350	230	230	140	150	250	8	220.5	272	540	0.61	1.4	2LC0171-5AG	120
400	14000	2000	66	150	51	180	400	250	250	160	180	250	8	185.5	311	590	1.1	2.8	2LC0171-6AG	190
440	19000	1900	80	160	51	190	440	265	265	180	180	250	10	182	354	610	1.7	4.0	2LC0171-7AG	219

Configurable variants<sup>1)</sup>

- ØD1 Without finished bore  
With finished bore
- ØD2 Without finished bore  
With finished bore

Notes

- For dimension U1, see type A on page 7/11.
- During assembly, the gap dimension S2 must not exceed the permissible tolerance of +1 mm.
- Weights and mass moments of inertia apply to maximum bores.

Ordering example

- N-EUPEX H coupling, size 160, S = 200 mm
- Part 1: Bore D1 60H7 mm, keyway to DIN 6885-1 and set screw
- Part 2: Bore D2 55H7 mm, keyway to DIN 6885-1 and set screw

Article no.: 2LC0170-7AG99-0AD0 L1E+M1D

<sup>1)</sup> To identify complete item numbers specifying the available finish boring options and – if necessary – further order options, please use our configurators on [flender.com](http://flender.com).

<sup>2)</sup> The hub diameter HD1 can be smaller for small bores

↗ For online configuration on [flender.com](http://flender.com), click on the item no.

# TYPE D

for easy elastomer flexible replacement

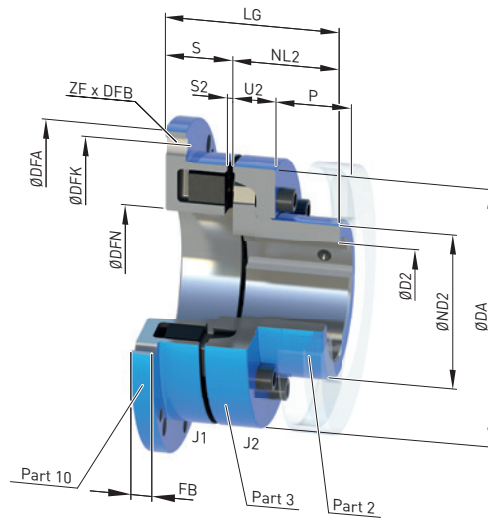

7

Size	Rated torque flexible type 80 ShoreA $T_{KN}$ Nm	Speed $n_{Kmax}$ rpm	Dimensions in mm										Flange connection dimensions						Mass moment of inertia $J_1$ kgm <sup>2</sup>   $J_2$ kgm <sup>2</sup>	Article no. <sup>1)</sup>	Weight $m$ kg
			Bore with keyway to DIN 6885-1		DA	ND2	NL2	S	$\Delta S$ +/-	S2	LG	DFA h8	DFN H7	DFK	FB	ZF	DFB				
110	225	6300	-	45	110	60.5	40	30	1.0	3	70	144	62	128	10	6	$\frac{9}{M8}$	0.0033	0.002	2LC0170-4AD1 2LC0170-4AD2	2.6
125	345	6000	-	55	125	73.5	50	34	1.0	3	84	158	75	142	10	6	$\frac{9}{M8}$	0.005	0.004	2LC0170-5AD1 2LC0170-5AD2	3.5
140	500	5300	-	60	140	80.5	55	37	1.0	3	92	180	82	160	13	6	$\frac{11}{M10}$	0.010	0.007	2LC0170-6AD1 2LC0170-6AD2	5.4
160	840	4800	-	70	160	93.5	60	43	2.0	4	103	200	95	180	13	7	$\frac{11}{M10}$	0.016	0.013	2LC0170-7AD1 2LC0170-7AD2	7.1
180	1250	4300	-	80	180	106	70	46	2.0	4	116	220	110	200	13	8	$\frac{11}{M10}$	0.025	0.023	2LC0170-8AD1 2LC0170-8AD2	9.5
200	1950	3900	-	90	200	119	80	51	2.0	4	131	248	120	224	16	8	$\frac{14}{M12}$	0.049	0.04	2LC0171-0AD1 2LC0171-0AD2	14
225	2300	3600	-	100	225	135	90	56	2.0	4	146	274	135	250	16	8	$\frac{14}{M12}$	0.076	0.07	2LC0171-1AD1 2LC0171-1AD2	19
250	3900	3000	-	115	250	153	100	65.5	2.5	5.5	165.5	314	150	282	20	8	$\frac{18}{M16}$	0.15	0.13	2LC0171-2AD1 2LC0171-2AD2	28
280	5500	3000	54	125	280	168	110	70.5	2.5	5.5	180.5	344	170	312	20	8	$\frac{18}{M16}$	0.23	0.2	2LC0171-3AD1 2LC0171-3AD2	35

### Configurable variants <sup>1)</sup>

- ØD2 Without finished bore  
With finished bore

<sup>1)</sup> To identify complete item numbers specifying the available finish boring options and – if necessary – further order options, please use our configurators on [flender.com](http://flender.com).

↗ For online configuration on [flender.com](http://flender.com), click on the item no.



Size	Rated torque flexible type 80 ShoreA $T_{KN}$ Nm	Speed $n_{Kmax}$ rpm	Dimensions in mm										Flange connection dimensions						Mass moment of inertia		Article no. <sup>1)</sup>	Weight $m$ kg
			Bore with keyway to DIN 6885-1		DA	ND2	NL2	S	$\Delta S$ +/-	S2	LG	DFA h8	DFN H7	DFK	FB	ZF	DFB	$J_1$ kgm <sup>2</sup>	$J_2$ kgm <sup>2</sup>			
D2 min.	max.																					
315	7100	2500	45	145	315	196	125	75.5	2.5	5.5	200.5	380	200	348	22	9	18 M16	0.4	0.37	2LC0171-4AD1 2LC0171-4AD2	48	
350	10800	2200	60	165	350	226	140	79.5	2.5	5.5	219.5	430	225	390	25	9	22 M20	0.7	0.64	2LC0171-5AD1 2LC0171-5AD2	68	
400	14000	2000	65	180	400	246	160	83.5	2.5	5.5	243.5	480	265	440	25	10	22 M20	1.1	1.1	2LC0171-6AD1 2LC0171-6AD2	89	
440	19000	1800	80	190	440	261	180	93.5	2.5	7.5	273.5	520	295	480	25	10	22 M20	1.6	1.7	2LC0171-7AD1 2LC0171-7AD2	117	
480	25100	1800	90	215	480	296	190	97.5	2.5	7.5	287.5	575	325	528	30	10	26 M24	2.6	2.7	2LC0171-8AD1 2LC0171-8AD2	149	
520	32400	1500	100	225	520	310	210	109.5	2.5	7.5	319.5	615	355	568	30	10	26 M24	3.6	3.8	2LC0172-0AD1 2LC0172-0AD2	182	

Configurable variants <sup>1)</sup>

- ØD2 Without finished bore  
With finished bore

Notes

- For dimensions U2 and P, see type A on page 7/11.
- Weights and mass moments of inertia apply to maximum bores.

Ordering example

- N-EUPEX D coupling, size 125
- Part 10: with through bores
- Part 2: Bore D2 38H7 mm, with keyway to DIN 6885-1 and set screw

Article no.: 2LC0170-5AD19-0AA0 M0V

<sup>1)</sup> To identify complete item numbers specifying the available finish boring options and – if necessary – further order options, please use our configurators on [flender.com](http://flender.com).

➤ For online configuration on [flender.com](http://flender.com), click on the item no.

# TYPE E

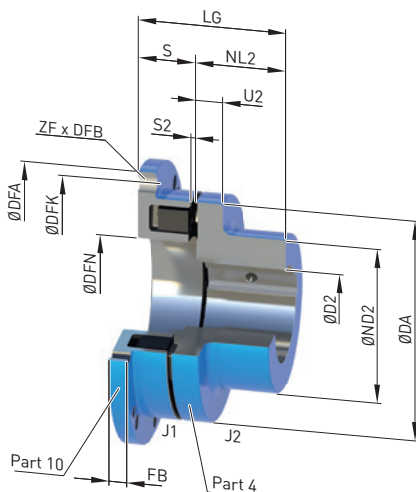

7

Size	Rated torque flexible type 80 ShoreA $T_{KN}$ Nm	Speed $n_{Kmax}$ rpm	Dimensions in mm											Mass moment of inertia			Article no. <sup>1)</sup>	Weight $m$ kg			
			Bore with keyway to DIN 6885-1		Flange connection dimensions									$J_1$ kgm <sup>2</sup>	$J_2$ kgm <sup>2</sup>						
			D2 min.	D2 max.	DA	ND2	NL2	S	$\Delta S$ +/-	S2	LG	DFA h8	DFN H7	DFK	FB	ZF	DFB				
68	48	8400	-	30	68	50	20	23	1.0	3	43	90	34	80	7	6	5.5 M5	0.0004	0.0002	2LC0170-1AC1 2LC0170-1AC2	0.7
80	85	7200	-	42	80	68	30	24	1.0	3	54	106	42	94	8	6	6.6 M6	0.0008	0.0006	2LC0170-2AC1 2LC0170-2AC2	1.2
95	140	6600	-	48	95	76	35	27	1.0	3	62	120	52	108	8	6	6.6 M6	0.0013	0.0012	2LC0170-3AC1 2LC0170-3AC2	1.7
110	225	6300	-	55	110	86	40	30	1.0	3	70	144	62	128	10	6	9 M8	0.0033	0.0024	2LC0170-4AC1 2LC0170-4AC2	2.6
125	345	6000	-	60	125	100	50	34	1.0	3	84	158	75	142	10	6	9 M8	0.005	0.005	2LC0170-5AC1 2LC0170-5AC2	4.0
140	500	5300	-	65	140	100	55	37	1.0	3	92	180	82	160	13	6	11 M10	0.010	0.007	2LC0170-6AC1 2LC0170-6AC2	5.5
160	840	4800	-	70	160	108	60	43	2.0	4	103	200	95	180	13	7	11 M10	0.016	0.01	2LC0170-7AC1 2LC0170-7AC2	7.1

### Configurable variants <sup>1)</sup>

- ØD2 Without finished bore  
With finished bore

<sup>1)</sup> To identify complete item numbers specifying the available finish boring options and – if necessary – further order options, please use our configurators on [flender.com](http://flender.com).

↗ For online configuration on [flender.com](http://flender.com), click on the item no.

Size	Rated torque flexible type 80 ShoreA $T_{KN}$ Nm	Speed $n_{Kmax}$ rpm	Dimensions in mm											Flange connection dimensions						Mass moment of inertia		Article no. <sup>1)</sup>	Weight $m$ kg
			Bore with keyway to DIN 6885-1		DA	ND2	NL2	S	$\Delta S$ +/-	S2	LG	DFA h8	DFN H7	DFK	FB	ZF	DFB	$J_1$ kgm <sup>2</sup>	$J_2$ kgm <sup>2</sup>				
			D2 min.	max.																			
180	1250	4300	-	80	180	125	70	46	2.0	4	116	220	110	200	13	8	$\frac{11}{M10}$	0.025	0.02	<u>2LC0170-8AC1</u> <u>2LC0170-8AC2</u>	10		
200	1950	3900	-	85	200	140	80	51	2.0	4	131	248	120	224	16	8	$\frac{14}{M12}$	0.049	0.04	<u>2LC0171-0AC1</u> <u>2LC0171-0AC2</u>	15		
225	2300	3600	-	90	225	150	90	56	2.0	4	146	274	135	250	16	8	$\frac{14}{M12}$	0.076	0.06	<u>2LC0171-1AC1</u> <u>2LC0171-1AC2</u>	19		
250	3900	3000	46	100	250	165	100	65.5	2.5	5.5	165.5	314	150	282	20	8	$\frac{18}{M16}$	0.15	0.11	<u>2LC0171-2AC1</u> <u>2LC0171-2AC2</u>	26		
280	5500	3000	54	110	280	180	110	70.5	2.5	5.5	180.5	344	170	312	20	8	$\frac{18}{M16}$	0.23	0.18	<u>2LC0171-3AC1</u> <u>2LC0171-3AC2</u>	34		

**Configurable variants <sup>1)</sup>**

- $\emptyset D2$  Without finished bore  
With finished bore

**Notes**

- For dimension U2, see type B on page 7/12.
- Weights and mass moments of inertia apply to maximum bores.

**Ordering example**

- N-EUPEX E coupling, size 125
- Part 10: with through bores
- Part 4: Bore D2 38H7 mm, with keyway to DIN 6885-1 and set screw

Article no.: **2LC0170-5AC19-0AA0 M0V**

<sup>1)</sup> To identify complete item numbers specifying the available finish boring options and – if necessary – further order options, please use our configurators on [flender.com](http://flender.com).

➤ For online configuration on [flender.com](http://flender.com), click on the item no.

# TYPE P

with brake drum

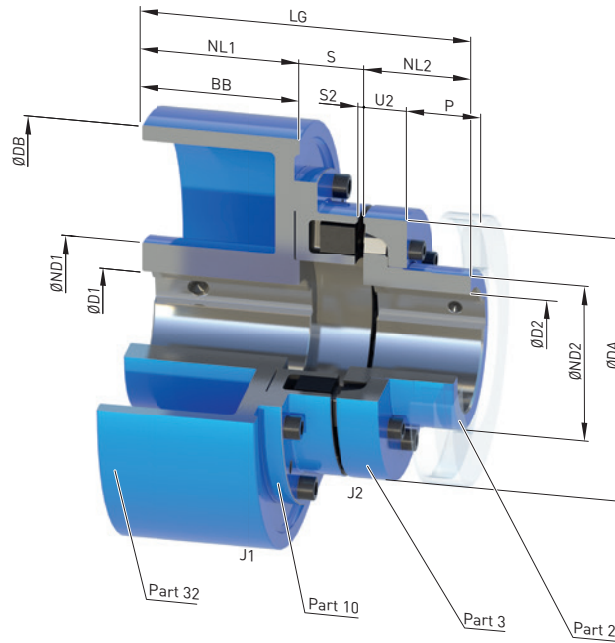

Size	Rated torque flexible type 80 ShoreA $T_{KN}$ Nm	Speed $n_{Kmax}$ rpm	Dimensions in mm											Mass moment of inertia		Article no. <sup>1)</sup>	Weight $m$ kg				
			Bore with keyway to DIN 6885-1		DA	ND1	ND2	NL1/BB	NL2	S	$\Delta S$ +/-	S2	DB	U2	LG			$J_1$ kgm <sup>2</sup>	$J_2$ kgm <sup>2</sup>		
			D1 min.	max.	D2 min.	max.															
125	345	4800	-	55	-	55	125	84	73.5	75	50	31	1.0	3	200	23	156	0.043	0.004	2LC0170-5AF	11
140	500	3800	-	60	-	60	140	128	80.5	95	55	34	1.0	3	250	28	184	0.13	0.007	2LC0170-6AF	21
160	840	3800	-	70	-	70	160	128	93.5	95	60	40	2.0	4	250	28	195	0.14	0.013	2LC0170-7AF	21
180	1250	3800	-	80	-	80	180	128	106	95	70	41	2.0	4	250	30	206	0.16	0.023	2LC0170-8AF	27
		3000	-	80	-	80	128	118	118	70	43	315			30	231	0.35	2LC0170-8AF		34	
200	1950	3000	-	80	-	80	128	118	118	70	48	2.0	4	315	30	246	0.37	0.04	2LC0171-0AF	39	
		2400	-	90	-	90	200	160	119	150	80			48	400	32	278		1.1	2LC0171-0AF	59
		1900	-	110	-	110	175	190	190	80	48			500	32	318	2.8		2LC0171-0AF	97	
225	2300	3000	-	80	-	80	128	118	118	70	51	2.0	4	315	30	259	0.39	0.07	2LC0171-1AF	46	
		2400	-	90	-	90	225	160	135	150	90			53	400	38	293		1.1	2LC0171-1AF	64
		1900	38	110	-	110	175	190	190	90	53			500	38	333	3.1		2LC0171-1AF	103	

### Configurable variants <sup>1)</sup>

- ØD1 Without finished bore  
With finished bore
- ØD2 Without finished bore  
With finished bore

<sup>1)</sup> To identify complete item numbers specifying the available finish boring options and – if necessary – further order options, please use our configurators on [flender.com](http://flender.com).

↗ For online configuration on [flender.com](http://flender.com), click on the item no.

Size	Rated torque flexible type 80 ShoreA $T_{KN}$ Nm	Speed $n_{Kmax}$ rpm	Dimensions in mm													Mass moment of inertia		Article no. <sup>1)</sup>	Weight $m$ kg		
			Bore with keyway to DIN 6885-1			D1	D2	DA	ND1	ND2	NL1/BB	NL2	S	$\Delta S$ +/-	S2	DB	U2			LG	$J_1$ kgm <sup>2</sup>
min.	max.	min.	max.																		
250	3900	2400	-	100	-	115	250	160	153	150	100	62.5	2.5	5.5	400	42	312.5	1.16	0.13	2LC0171-2AF	74
		1900	38	110	-	115	250	175	190	190	100	62.5	2.5	5.5	500	42	352.5	2.9		2LC0171-2AF	111
		2400	-	100	-	115	250	160	150	150	100	65.5	2.5	5.5	400	42	325.5	1.24		2LC0171-3AF	82
280	5500	1900	48	110	54	125	280	175	168	190	110	67.5	2.5	5.5	500	42	367.5	3.1	0.2	2LC0171-3AF	115
		1500	48	110	-	125	280	175	236	236	110	67.5	2.5	5.5	630	42	413.5	8.0		2LC0171-3AF	168
		2400	-	100	-	125	280	160	150	150	110	72.5	2.5	5.5	400	42	347.5	1.4		2LC0171-4AF	92
315	7100	1900	48	110	45	145	315	175	196	190	125	72.5	2.5	5.5	500	47	387.5	3.3	0.37	2LC0171-4AF	131
		1500	48	110	-	145	315	175	236	236	125	72.5	2.5	5.5	630	47	433.5	8.2		2LC0171-4AF	180
		1300	55	120	-	145	315	192	265	265	125	72.5	2.5	5.5	710	47	462.5	14.2		2LC0171-4AF	233
350	10800	1500	48	110	60	165	350	175	226	236	140	76.5	2.5	5.5	630	51	452.5	8.5	0.64	2LC0171-5AF	197
		1300	55	120	-	165	350	192	265	265	140	76.5	2.5	5.5	710	51	481.5	14.6		2LC0171-5AF	251

Configurable variants <sup>1)</sup>

- ØD1 Without finished bore  
With finished bore
- ØD2 Without finished bore  
With finished bore

Notes

- For dimension P, see type A on page 7/11.
- Weights and mass moments of inertia apply to maximum bores.

Ordering example

- N-EUPEX P coupling, size 200, brake drum 315 x 118 mm
- Part 32: Bore D1 55H7 mm, keyway to DIN 6885-1 P9 and set screw
- Part 4: Bore D2 60H7 mm, keyway to DIN 6885-1 and set screw
- Coupling micro-balanced G 6.3 at 1500 rpm in accordance with half parallel key standard

Article no.: 2LC0171-0AF99-0DA0-Z L1D+M1E+W02+Y95  
Plain text to Y95: G=6.3;n=1500rpm

<sup>1)</sup> To identify complete item numbers specifying the available finish boring options and – if necessary – further order options, please use our configurators on [flender.com](http://flender.com).

➤ For online configuration on [flender.com](http://flender.com), click on the item no.

# TYPE O

with brake drum

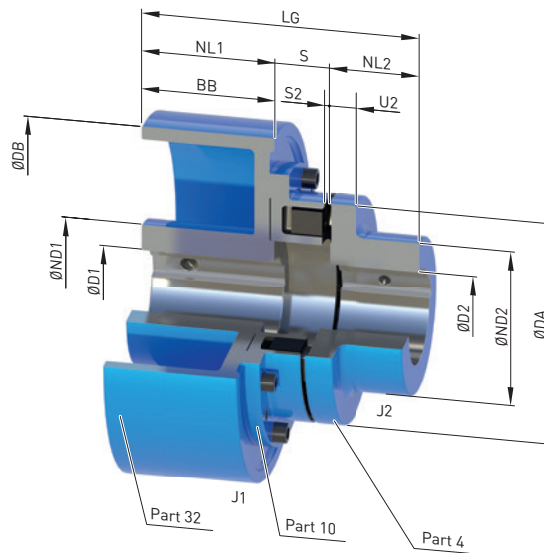

7

Size	Rated torque flexible type 80 ShoreA $T_{KN}$ Nm	Speed $n_{Kmax}$ rpm	Dimensions in mm														Mass moment of inertia		Article no. <sup>1)</sup>	Weight $m$ kg	
			Bore with keyway to DIN 6885-1				DA	ND1	ND2	NL1/BB	NL2	S	$\Delta S$ +/-	S2	DB	U2	LG	$J_1$ kgm <sup>2</sup>			$J_2$ kgm <sup>2</sup>
D1	D2	D1	D2																		
min.	max.	min.	max.																		
125	345	4800	-	55	-	60	125	84	100	75	50	31	1.0	3	200	18	156	0.043	0.005	2LC0170-5AE	11
140	500	3800	-	60	-	65	140	128	100	95	55	34	1.0	3	250	20	184	0.13	0.007	2LC0170-6AE	22
160	840	3800	-	70	-	70	160	128	108	95	60	40	2.0	4	250	20	195	0.14	0.01	2LC0170-7AE	24
180	1250	3800	-	80	-	80	180	128	125	95	70	41	2.0	4	250	20	206	0.16	0.02	2LC0170-8AE	28
		3000	-	80	118	43				315		231			0.35		2LC0170-8AE	35			
200	1950	3000	-	80	-	85	200	160	140	118	80	48	2.0	4	315	24	246	0.37	0.04	2LC0171-0AE	40
		2400	-	90	128	48				315		246			1.10		2LC0171-0AE	60			
		1900	-	110	175	190				48		500			318		2.80	2LC0171-0AE		98	

### Configurable variants <sup>1)</sup>

- ØD1 Without finished bore  
With finished bore
- ØD2 Without finished bore  
With finished bore

<sup>1)</sup> To identify complete item numbers specifying the available finish boring options and – if necessary – further order options, please use our configurators on flender.com.

↗ For online configuration on flender.com, click on the item no.

Size	Rated torque flexible type 80 ShoreA $T_{KN}$ Nm	Speed		Dimensions in mm												Mass moment of inertia		Article no. <sup>1)</sup>	Weight $m$ kg				
		$n_{Kmax}$ rpm		Bore with keyway to DIN 6885-1													$J_1$ kgm <sup>2</sup>			$J_2$ kgm <sup>2</sup>			
			min.	max.	D2 min.	max.	DA	ND1	ND2	NL1/BB	NL2	S	$\Delta S$ +/-	S2	DB	U2	LG						
225	2300	3000	-	80				128	118			51			315	18	259	0.39			2LC0171-1AE	45	
		2400	-	90	-	90	225	160	150	150	90	53	2.0	4	400	18	293	1.10	0.06			2LC0171-1AE	63
		1900	38	110				175	190			53			500	18	333	3.10				2LC0171-1AE	102
250	3900	2400	-	100				160	165	150		62.5	2.5	5.5	400	18	312.5	1.16			2LC0171-2AE	73	
		1900	38	110	46	100	250	175	190	190	100	62.5			500	18	352.5	2.90	0.11			2LC0171-2AE	108
		2400	-	100				160	150			65.5			400	18	325.5	1.24				2LC0171-3AE	82
280	5500	1900	48	110	54	110	280	175	180	190	110	67.5	2.5	5.5	500	20	367.5	3.10	0.18			2LC0171-3AE	115
		1500	48	110				175	236			67.5			630	20	413.5	8.0				2LC0171-3AE	168

Configurable variants <sup>1)</sup>

- ØD1 Without finished bore  
With finished bore
- ØD2 Without finished bore  
With finished bore

Notes

- Weights and mass moments of inertia apply to maximum bores.

Ordering example

- N-EUPEX O coupling, size 200, brake drum 315 x 118 mm
- Part 32: Bore D1 55H7 mm, keyway to DIN 6885-1 P9 and set screw
- Part 4: Bore D2 60H7 mm, keyway to DIN 6885-1 and set screw
- Coupling micro-balanced G 6.3 at 1500 rpm in accordance with half parallel key standard

Article no.: 2LC0171-0AE99-0DA0-Z L1D+M1E+W02+Y95  
Plain text to Y95: G=6.3;n=1500rpm

<sup>1)</sup> To identify complete item numbers specifying the available finish boring options and – if necessary – further order options, please use our configurators on [flender.com](http://flender.com).

➤ For online configuration on [flender.com](http://flender.com), click on the item no.

# TYPE DBDR

with brake disk

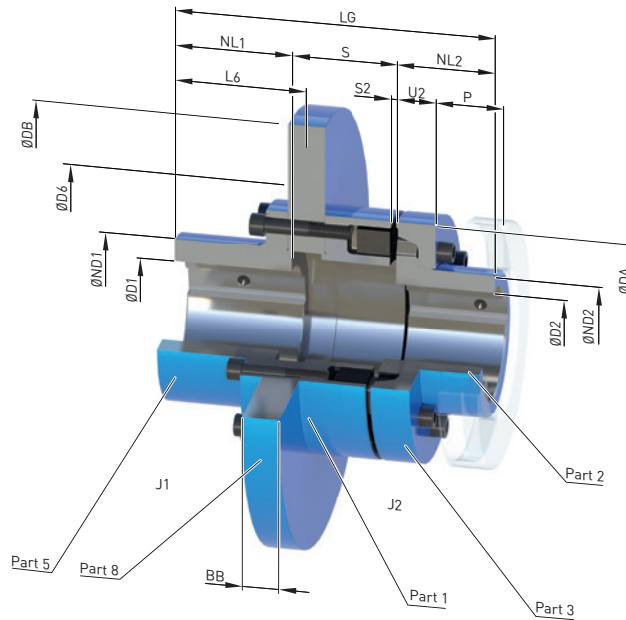

Size	Rated torque flexible type 80 ShoreA $T_{KN}$ Nm	Dimensions in mm																Mass moment of inertia		Article no. <sup>1)</sup>	Weight $m$ kg
		Bore with keyway to DIN 6885-1			DA	ND1	ND2	NL1	NL2	S	$\Delta S$ +/-	S2	DB <sup>2)</sup> min.	D6 min.	BB <sup>2)</sup>	L6	LG	$J_1$ min. kgm <sup>2</sup>	$J_2$ kgm <sup>2</sup>		
		D1 max.	D2 min.	max.																	
140	500	60	-	60	140	85	80.5	72	55	54.35	1.0	3	315	150	12.7	74	181.35	0.11	0.008	2LC0170-6AV	14.7
								188	73	57.5					30	200	316	0.24			16.2
								90	60	62.5					12.7	91	208.35	0.12			26.9
160	840	75	-	70	160	105	93.5	90	60	58.35	2.0	4	315	170	15	94	212.5	0.14	0.013	2LC0170-7AV	18.5
								188	78	62.5					30	200	326	0.26			20
								90	70	60.35					12.7	91	220.35	0.35			31
180	1250	90	-	80	180	125	106	90	70	64.5	2.0	4	315	190	15	94	224.5	0.37	0.024	2LC0170-8AV	25
								188	80	67.35					30	200	338	0.57			26
								95	80	67.35					12.7	97	242.35	0.32			42
200	1950	95	-	90	200	135	119	95	80	70.5	2.0	4	355	210	15	99	245.5	0.36	0.04	2LC0171-0AV	32
								188	86	70.5					30	200	354	0.67			35
								95	80	70.5					12.7	97	242.35	0.32			54

## Configurable variants <sup>1)</sup>

- ØD1 With finished bore
- ØD2 Without finished bore  
With finished bore

<sup>1)</sup> To identify complete item numbers specifying the available finish boring options and – if necessary – further order options, please use our configurators on [flender.com](http://flender.com).

<sup>2)</sup> For the available DB · BB brake disk dimensions, please refer to the product configurator on [flender.com](http://flender.com).

➤ For online configuration on [flender.com](http://flender.com), click on the item no.



Size	Rated torque flexible type 80 ShoreA $T_{KN}$ Nm	Dimensions in mm															Mass moment of inertia		Article no. <sup>1)</sup>	Weight $m$ kg	
		Bore with keyway to DIN 6885-1			DA	ND1	ND2	NL1	NL2	S	$\Delta S$ +/-	S2	DB <sup>2)</sup> min.	D6 min.	BB <sup>2)</sup>	L6	LG	$J_1$ min. kgm <sup>2</sup>			$J_2$ kgm <sup>2</sup>
225	2300	115	-	100	225	160	135	100	90	72.35	2.0	4	400	235	12.7	103	262.35	0.52	0.08	2LC0171-1AV	43
					188	90	74.5	30	200	368					1.1	46					
					105	83.35	12.7	107	288.35	1.6					71						
250	3900	120	-	115	250	170	153	105	100	86.5	+2/-3	6	450	260	15	109	291.5	1.7	0.12	2LC0171-2AV	56
					188	102	30	200	390	2.5					59						
					120	87.35	12.7	122	317.35	1.3					88						
280	5500	140	54	125	280	200	168	120	110	90.5	+2/-3	6	500	350	15	124	320.5	1.5	0.19	2LC0171-3AV	73
					188	106	30	200	404	2.7					77						
					130	87.35	12.7	130	342.35	2.1					112						
315	7100	140	45	145	315	200	196	130	125	92.5	+2/-3	6	500	350	15	134	347.5	2.3	0.33	2LC0171-4AV	95
					188	108	30	200	421	4.2					100						
					135	97.35	12.7	136	372.35	3.3					140						
350	10800	165	60	165	350	230	226	135	140	101.5	+2/-3	6	500	360	15	139	376.5	3.8	0.57	2LC0171-5AV	129
					188	117	30	200	445	6.7					134						
					135	97.35	12.7	136	372.35	3.3					184						

Configurable variants <sup>1)</sup>

- ØD1 With finished bore
- ØD2 Without finished bore  
With finished bore

Notes

- For dimensions U2 and P, see type A on page 7/11.
- Weights and mass moments of inertia apply to maximum bores.
- Maximum speed  $n_{max} = 1528/DB$  ( $n_{max}$  in rpm, DB in m)  
Observe maximum speed of type A.
- Other brake disk diameters DB and brake disk widths BB on request.

Ordering example

- N-EUPEX DBDR coupling, size 200,  
brake disk 450 x 30 mm
- Part 5: Bore D1 55H7 mm, keyway to DIN 6885-1 P9  
and set screw
- Part 2: Bore D2 60H7 mm, keyway to DIN 6885-1  
and set screw
- Coupling micro-balanced G 6.3 at 1500 rpm in accordance with  
half parallel key standard

Article no.: 2LC0171-0AV99-0GA0-Z L1D+M1E+W02+Y95  
Plain text to Y95: G=6.3;n=1500rpm

<sup>1)</sup> To identify complete item numbers specifying the available finish boring options and – if necessary – further order options, please use our configurators on [flieder.com](http://flieder.com).

<sup>2)</sup> For the available DB · BB brake disk dimensions, please refer to the product configurator on [flieder.com](http://flieder.com).

↗ For online configuration on [flieder.com](http://flieder.com), click on the item no.

# TYPE ABD

with brake disk

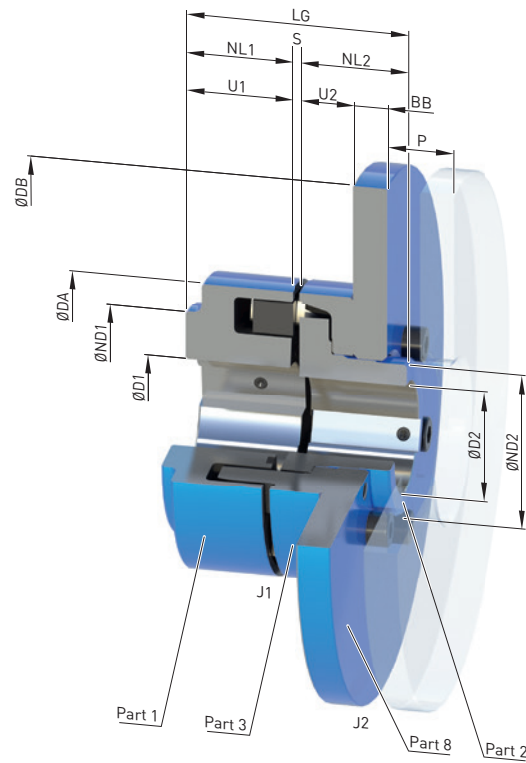

Size	Rated torque flexible type 80 ShoreA $T_{KN}$ Nm	Speed $n_{Kmax}$ rpm	Dimensions in mm Bore with keyway to DIN 6885-1														Mass moment of inertia		Article no. <sup>1)</sup>	Weight $m$ kg		
			D1		D2		DA	ND1 <sup>2)</sup>	ND2	NL1/NL2	S	$\Delta S$ +/-	U1	U2	P	DB <sup>3)</sup>	BB <sup>3)</sup>	LG			$J_1$ kgm <sup>2</sup>	$J_2$ kgm <sup>2</sup>
			min.	max.	min.	max.									min.							
140	500	5500	-	65	-	60	140	100	80.5	55	3	1.0	34	28	43	315	12.7	113	0.007	0.10	2LC0170-6BB	12.8
160	840	5100	-	70	-	70	160	108	93.5	60	4	2.0	39	28	47	315	12.7	124	0.013	0.11	2LC0170-7BB	14.8
180	1250	4500	-	80	-	80	180	125	106	70	4	2.0	42	30	50	355	12.7	144	0.023	0.18	2LC0170-8BB	20
200	1950	4000	-	85	-	90	200	140	119	80	4	2.0	47	32	53	400	12.7	164	0.04	0.29	2LC0171-0BB	27
225	2300	3600	-	90	-	100	225	150	135	90	4	2.0	52	38	61	450	30	184	0.07	1.0	2LC0171-1BB	57
250	3900	3300	46	100	-	115	250	165	153	100	5.5	2.5	60	42	69	500	30	205.5	0.13	1.6	2LC0171-2BB	73
280	5500	3000	49	110	54	125	280	180	168	110	5.5	2.5	65	42	73	560	30	225.5	0.20	2.5	2LC0171-3BB	94
315	7100	2600	49	120	45	145	315	200	196	125	5.5	2.5	70	47	78	630	30	255.5	0.37	4.0	2LC0171-4BB	126
350	10800	2400	61	140	60	165	350	230	226	140	5.5	2.5	74	51	83	710	30	285.5	0.64	6.5	2LC0171-5BB	167

### Configurable variants <sup>1)</sup>

- ØD1 Without finished bore  
With finished bore
- ØD2 Without finished bore  
With finished bore

### Notes

- Weights and mass moments of inertia apply to maximum bores.

### Ordering example

- N-EUPEX ABD coupling, size 200, brake disk 400 x 12.7 mm
- Part 1: Bore D1 65H7 mm, keyway to DIN 6885-1 and set screw
- Part 2: Bore D2 50H7 mm, keyway to DIN 6885-1 P9 and set screw
- Coupling micro-balanced G 6.3 at 1500 rpm in accordance with half parallel key standard

Article no.: 2LC0171-0BB99-2FA0-Z L1F+M1C+W02+Y95  
Plain text to Y95: G=6.3;n=1500rpm

<sup>1)</sup> To identify complete item numbers specifying the available finish boring options and – if necessary – further order options, please use our configurators on [flender.com](http://flender.com).

<sup>2)</sup> The hub diameter HD1 can be smaller for small bores.

<sup>3)</sup> For the available DB · BB brake disk dimensions, please refer to the product configurator on [flender.com](http://flender.com).

↗ For online configuration on [flender.com](http://flender.com), click on the item no.

# TYPE ERN

with slip unit

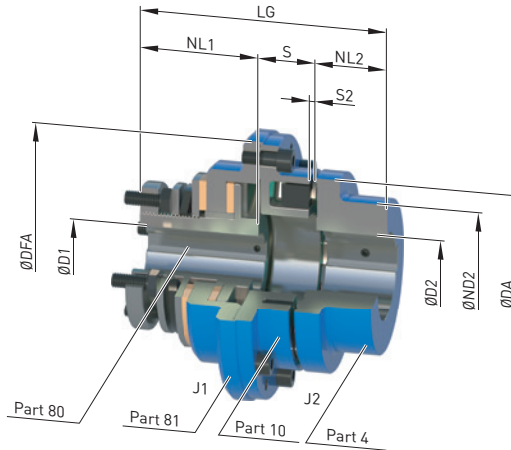

7

Size	Rated torque flexible type 80 ShoreA $T_{KN}$ Nm	Slip torque		Speed $n_{Kmax}$ rpm	Dimensions in mm											Mass moment of inertia		Article no. <sup>1)</sup>	Weight $m$ kg
		$T_{R1}$ Nm	$T_{R2}$ Nm		D1 max.	D2 max.	DA	ND2	NL1	NL2	S	$\Delta S$ +/-	S2	DFA	LG	$J_1$ kgm <sup>2</sup>	$J_2$ kgm <sup>2</sup>		
80	85	130	240	3800	30	42	80	68	55	30	25	1.0	3	109	110	0.0039	0.0006	2LC0170-2BE	3.3
95	140	190	340	3600	35	48	95	76	66	35	28	1.0	3	123	129	0.007	0.0012	2LC0170-3BE	4.8
110	225	190	340	3600	35	55	110	86	66	40	31	1.0	3	147	137	0.010	0.0024	2LC0170-4BE	5.8
125	345	350	650	3000	45	60	125	100	77	50	35	1.0	3	161	162	0.017	0.005	2LC0170-5BE	8.9
140	500	650	1200	2500	60	65	140	100	86	55	38	1.0	3	183	179	0.035	0.008	2LC0170-5BE	13
160	840	650	1200	2500	60	70	160	108	86	60	44	2.0	4	204	190	0.050	0.013	2LC0170-7BE	15
180	1250	1000	1800	2100	65	80	180	125	93	70	47	2.0	4	224	210	0.084	0.025	2LC0170-8BE	22
200	1950	2200	4000	1800	80	85	200	140	105	80	52	2.0	4	252	237	0.16	0.044	2LC0171-0BE	32
225	2300	2200	4000	1800	80	90	225	150	105	90	57	2.0	4	278	252	0.22	0.064	2LC0171-1BE	37
250	3900	3800	6800	1500	90	100	250	165	120	100	66.5	2.5	5.5	319	286.5	0.51	0.10	2LC0171-2BE	60
280	5500	5500	10000	1500	120	110	280	180	120	110	71.5	2.5	5.5	349	301.5	0.77	0.17	2LC0171-3BE	74

### Configurable variants<sup>1)</sup>

- ØD1 With finished bore
- ØD2 Without finished bore  
With finished bore

### Notes

- Weights and mass moments of inertia apply to maximum bores.

### Ordering example

- N-EUPEX ERN coupling, size 200  
Slip torque  $T_R = 4000$  Nm
- Part 1: Bore D1 65H7 mm, keyway to DIN 6885-1 and set screw
- Part 2: Bore D2 50H7 mm, keyway to DIN 6885-1 and set screw

Article no.: 2LC0171-0BE99-2AA0 L1F+M1C

<sup>1)</sup> To identify complete item numbers specifying the available finish boring options and – if necessary – further order options, please use our configurators on [flender.com](http://flender.com).

↗ For online configuration on [flender.com](http://flender.com), click on the item no.



# GENERAL

## Technical specifications, N-EUPEX DS series

Power ratings of the N-EUPEX DS series						
Size	Rated torque	Maximum torque	Torsional stiffness at 50 % capacity utilization <sup>1)</sup>	Assembly	Permitted shaft misalignment at speed <sup>3)</sup> $n = 1500$ rpm	
	$T_{KN}$ Nm	$T_{Kmax}$ Nm	$C_{Tdyn}$ kNm/rad	Gap dimension <sup>2)</sup> $\Delta S$ mm	Radial $\Delta K_r$ mm	Angle $\Delta K_w$ °
66	19	38	0.73	1.0	0.2	0.15
76	34	68	1.36	1.0	0.2	0.15
88	60	120	2.62	1.0	0.2	0.12
103	100	200	4.00	1.0	0.2	0.12
118	160	320	6.30	1.0	0.2	0.10
135	240	480	10.5	1.0	0.25	0.10
152	360	720	13.6	1.0	0.25	0.10
172	560	1120	27.2	2.0	0.3	0.10
194	880	1760	47.0	2.0	0.3	0.10
218	1340	2680	70.0	2.0	0.3	0.09
245	2000	4000	106	2.0	0.35	0.09
272	2800	5600	149	2.5	0.35	0.08
305	3900	7800	214	2.5	0.4	0.08
340	5500	11000	350	2.5	0.4	0.08
380	7700	15400	480	2.5	0.5	0.08
430	10300	20600	730	2.5	0.5	0.08
472	13500	27000	990	2.5	0.6	0.08
514	16600	33200	1270	2.5	0.6	0.07
556	21200	42400	1540	2.5	0.65	0.07

For coupling fatigue torque:

$T_{KW} = 0,15 \cdot T_{KN}$ , where  $T_N > T_W$  must be adhered to.

### Note

For fitting, the maximum gap dimension of  $S_{max.} = S + \Delta S$  and the minimum gap dimension of  $S_{min.} = S - \Delta S$  are permitted.

<sup>1)</sup> The correction factors for torsion spring stiffness and permitted shaft misalignment correspond to the specifications for the puncture-proof types [page 7/9](#)

<sup>2)</sup> Does not apply to type HDS.

<sup>3)</sup> The maximum speed for the respective type must be noted. For additional information on the allowable shaft misalignment, please refer to the operating instructions.

# TYPE ADS

for easy elastomer flexible replacement

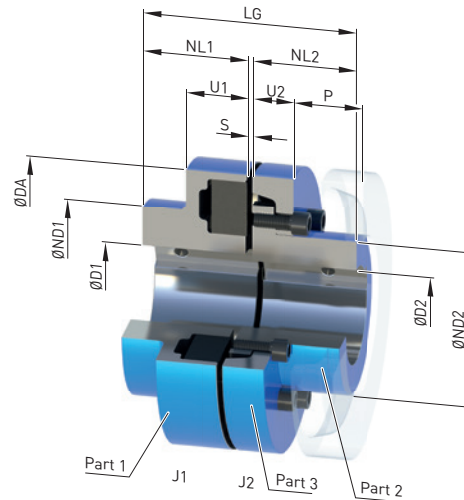

Size	Rated torque $T_{KN}$ Nm	Speed $n_{Kmax}$ rpm	Dimensions in mm													Mass moment of inertia $J_1/J_2$ kgm <sup>2</sup>	Article no. <sup>1)</sup>	Weight $m$ kg
			Bore with keyway to DIN 6885-1				DA	ND1	ND2	NL1/ NL2	S	U1	U2	P	LG			
			D1	D2	min.	max.												
118	160	5300	-	50	-	45	118	86	60.5	40	3	34	20	33	83	0.003	2LC0110-4AB	2.8
135	240	5100	-	60	-	55	135	100	73.5	50	3	36	23	38	103	0.005	2LC0110-5AB	4.3
152	360	4900	-	65	-	60	152	108	80.5	55	3	36	28	43	113	0.008	2LC0110-6AB	5.9
172	560	4250	-	70	-	70	172	118	93.5	60	4	41	28	47	124	0.014	2LC0110-7AB	8.2
194	880	3800	-	80	-	80	194	135	106	70	4	44	30	50	144	0.025	2LC0110-8AB	12
218	1340	3400	-	85	-	90	218	150	119	80	4	47	32	53	164	0.05	2LC0111-0AB	17
245	2000	3000	-	90	-	100	245	150	135	90	4	52	38	61	184	0.08	2LC0111-1AB	23
272	2800	2750	46	100	-	115	272	165	153	100	5.5	60	42	69	205.5	0.14	2LC0111-2AB	32
305	3900	2450	49	110	54	125	305	180	168	110	5.5	65	42	73	225.5	0.22	2LC0111-3AB	43
340	5500	2150	49	120	45	145	340	200	196	125	5.5	70	47	78	255.5	0.39	2LC0111-4AB	61
380	7700	2000	61	140	60	165	380	230	226	140	5.5	74	51	83	285.5	0.69	2LC0111-5AB	86
430	10300	1700	66	150	65	180	430	250	246	160	5.5	78	56	88	325.5	1.2	2LC0111-6AB	120
472	13500	1550	80	160	80	190	472	265	261	180	7.5	86	64	99	367.5	1.9	2LC0111-7AB	161
514	16600	1400	90	180	90	215	514	300	296	190	7.5	90	65	104	387.5	2.9	2LC0111-8AB	206
556	21200	1300	100	190	100	225	556	315	310	210	7.5	102	68	115	427.5	4.1	2LC0112-0AB	256

### Configurable variants <sup>1)</sup>

- ØD1 Without finished bore  
With finished bore
- ØD2 Without finished bore  
With finished bore

### Notes

- Weights and mass moments of inertia apply to maximum bores.

### Ordering example

- N-EUPEX ADS coupling, size 135
- Part 1: Bore D1 42H7 mm, keyway to DIN 6885-1 and set screw
- Part 2: Bore D2 32H7 mm, keyway to DIN 6885-1 and set screw

Article no.: 2LC0110-5AB99-0AA0 L0X+M0T

<sup>1)</sup> To identify complete item numbers specifying the available finish boring options and – if necessary – further order options, please use our configurators on [flender.com](http://flender.com).

↗ For online configuration on [flender.com](http://flender.com), click on the item no.

# TYPE BDS

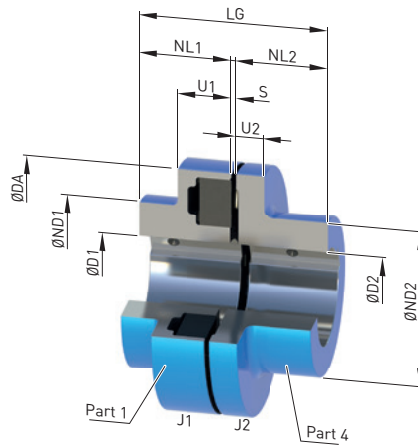

Size	Rated torque $T_{KN}$ Nm	Speed $n_{Kmax}$ rpm	Dimensions in mm											Mass moment of inertia $J_1/J_2$ kgm <sup>2</sup>	Article no. <sup>1)</sup>	Weight $m$ kg	
			Bore with keyway to DIN 6885-1				DA	ND1	ND2	NL1/ NL2	S	U1	U2				LG
			D1 min.	D1 max.	D2 min.	D2 max.											
66	19	7500	-	20	-	25	66	66	40	20	3	20	8	43	0.0001	2LC0110-0AA	0.46
76	34	7000	-	28	-	30	76	76	50	20	3	20	8	43	0.0002	2LC0110-1AA	0.64
88	60	6000	-	35	-	42	88	88	68	30	3	30	10	63	0.0008	2LC0110-2AA	1.4
103	100	5500	-	45	-	48	103	76	76	35	3	30	12	73	0.0015	2LC0110-3AA	2.1
118	160	5300	-	50	-	55	118	86	86	40	3	34	14	83	0.003	2LC0110-4AA	3.0
135	240	5100	-	60	-	60	135	100	100	50	3	36	18	103	0.006	2LC0110-5AA	5.1
152	360	4900	-	65	-	65	152	108	100	55	3	36	20	113	0.009	2LC0110-6AA	6.4
172	560	4250	-	70	-	70	172	118	108	60	4	41	20	124	0.016	2LC0110-7AA	8.7
194	880	3800	-	80	-	80	194	135	125	70	4	44	20	144	0.028	2LC0110-8AA	13
218	1340	3400	-	85	-	85	218	150	140	80	4	47	24	164	0.052	2LC0111-0AA	19
245	2000	3000	-	90	-	90	245	150	150	90	4	52	18	184	0.078	2LC0111-1AA	24
272	2800	2750	46	100	46	100	272	165	165	100	5.5	60	18	205.5	0.13	2LC0111-2AA	32
305	3900	2450	49	110	54	110	305	180	180	110	5.5	65	20	225.5	0.21	2LC0111-3AA	43

### Configurable variants <sup>1)</sup>

- ØD1 Without finished bore  
With finished bore
- ØD2 Without finished bore  
With finished bore

### Ordering example

- N-EUPEX BDS coupling, size 103
- Part 1: Bore D1 42H7 mm, keyway to DIN 6885-1 and set screw
- Part 4: Bore D2 32H7 mm, keyway to DIN 6885-1 and set screw

Article no.: 2LC0110-3AA99-0AA0 L0X+M0T

### Notes

- Weights and mass moments of inertia apply to maximum bores.

<sup>1)</sup> To identify complete item numbers specifying the available finish boring options and – if necessary – further order options, please use our configurators on [flender.com](http://flender.com).

➤ For online configuration on [flender.com](http://flender.com), click on the item no.

# TYPE HDS

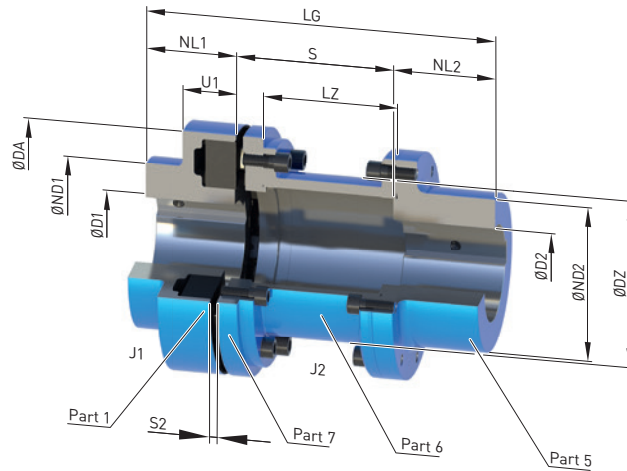

7

Size	Rated torque $T_{KN}$ Nm	Speed $n_{Kmax}$ rpm	Dimensions in mm													Mass moment of inertia		Article no. <sup>1)</sup>	Weight $m$ kg			
			Bore with keyway to DIN 6885-1						DA	ND1	ND2	NL1	NL2	S	S2	LZ	DZ			LG	$J_1$ kgm <sup>2</sup>	$J_2$ kgm <sup>2</sup>
			D1 min.	D1 max.	D2 min.	D2 max.																
88	60	6000	-	35	-	38 <sup>2)</sup>	88	88	55	30	45	100	5	87	175	0.0007	0.0014	2LC0110-2AC	2.6			
												140		127			215			0.0015		
103	100	5500	-	45	-	48 <sup>2)</sup>	103	76	70	35	45	100	5	87	180	0.001	0.0029	2LC0110-3AC	3.8			
												140		127			220			0.0032		
118	160	5300	-	50	-	55 <sup>2)</sup>	118	86	80	40	50	100	85	190	0.003	0.0059	2LC0110-4AC	4.9				
											50		140			125			230			
											60	180	165	280	0.0066	2LC0110-4AC	5.7					
											60	180	165	280	0.0066	2LC0110-4AC	5.7					
135	240	5100	-	60	-	60 <sup>2)</sup>	135	100	90	50	50	100	85	200	0.01	0.01	2LC0110-5AC	7.3				
											50		140			125			240			
											60	180	165	290	0.006	0.012	2LC0110-5AC	7.8				
											70	200	185	320	0.012	2LC0110-5AC	8.5					
											80	250	235	380	0.013	2LC0110-5AC	9.0					
											80	250	235	380	0.013	2LC0110-5AC	9.0					
152	360	4900	-	65	-	65 <sup>2)</sup>	152	108	100	55	65	100	82	220	0.011	0.02	2LC0110-6AC	10.8				
											65		140			122			260			
											65	180	162	300	0.022	2LC0110-6AC	11.8					
											65	200	182	320	0.023	2LC0110-6AC	12.1					
											80	250	232	385	0.024	2LC0110-6AC	12.6					

### Configurable variants <sup>1)</sup>

- ØD1 Without finished bore  
With finished bore
- ØD2 Without finished bore  
With finished bore

<sup>1)</sup> To identify complete item numbers specifying the available finish boring options and – if necessary – further order options, please use our configurators on [flender.com](http://flender.com).

<sup>2)</sup> For bore diameters greater than the following values, the feather key must be at least 3 mm behind the shaft end. Gr. 88 D2 > 32 mm; Gr. 103 D2 > 42 mm; Gr. 118 D2 > 50 mm; Gr. 135 D2 > 59 mm; Gr. 152 D2 > 64 mm.

↗ For online configuration on [flender.com](http://flender.com), click on the item no.



Size	Rated torque $T_{KN}$ Nm	Speed $n_{Kmax}$ rpm	Dimensions in mm														Mass moment of inertia		Article no. <sup>1)</sup>	Weight $m$ kg			
			Bore with keyway to DIN 6885-1				DA	ND1	ND2	NL1	NL2	S	S2	LZ	DZ	LG	$J_1$ kgm <sup>2</sup>	$J_2$ kgm <sup>2</sup>					
			D1 min.	D1 max.	D2 min.	D2 max.																	
172	560	4250	-	70	-	70	172	118	108	60	70	100	81.5	230	0.019	0.03	2LC0110-7AC	13.8					
																	70	140	121.5	270	0.034	2LC0110-7AC	14.5
																	70	180	161.5	111	0.036	2LC0110-7AC	15.4
																	70	200	181.5	330	0.037	2LC0110-7AC	15.7
																	80	250	231.5	390	0.039	2LC0110-7AC	16.7
194	880	3800	-	80	-	80	194	135	125	70	80	140	121.5	290	0.037	0.057	2LC0110-8AC	20					
																	180	161.5	131	330	0.061	2LC0110-8AC	21
																	200	181.5	350	0.063	2LC0110-8AC	22	
																	250	231.5	400	0.068	2LC0110-8AC	23	
																	140	118.5	310	0.10	2LC0111-0AC	30	
218	1340	3400	-	85	-	90	218	150	140	80	90	180	158.5	144	0.062	0.11	2LC0111-0AC	31					
																	200	178.5	370	0.11	2LC0111-0AC	32	
																	250	228.5	420	0.12	2LC0111-0AC	33	
																	140	118.5	330	0.16	2LC0111-1AC	34	
																	180	158.5	370	0.17	2LC0111-1AC	35	
245	2000	3000	-	90	-	95	245	150	150	90	100	200	178.5	169	0.09	0.18	2LC0111-1AC	36					
																	250	228.5	390	0.18	2LC0111-1AC	36	
																	250	228.5	440	0.19	2LC0111-1AC	38	
																	180	152.5	390	0.3	2LC0111-2AC	51	
																	200	172.5	410	0.16	2LC0111-2AC	52	
272	2800	2750	46	100	46	100	272	165	165	100	110	250	222.5	215	480	0.28	0.51	2LC0111-3AC	71				
																		250	222.5	460	0.33	2LC0111-2AC	55
																		250	222.5	480	0.50	0.85	2LC0111-4AC
305	3900	2450	49	110	51	130	305	180	180	110	120	250	8	222.5	215	480	0.28	0.51	2LC0111-3AC	71			
340	5500	2150	49	120	51	140	340	200	200	125	140	250	8	222.5	246	515	0.50	0.85	2LC0111-4AC	101			
380	7700	2000	61	140	51	160	380	230	230	140	150	250	8	220.5	272	540	0.80	1.4	2LC0111-5AC	125			
430	10300	1700	66	150	51	180	430	250	250	160	180	250	8	185.5	311	590	1.4	2.4	2LC0111-6AC	195			
472	13500	1550	80	160	51	190	472	265	265	180	180	250	10	182	354	610	2.1	4.0	2LC0111-7AC	224			

Configurable variants<sup>1)</sup>

- ØD1 Without finished bore  
With finished bore
- ØD2 Without finished bore  
With finished bore

Notes

- For dimension U1, see type ADS on page 7/32 and type BDS on page 7/33.
- During assembly, the gap dimension S2 must not exceed the permissible tolerance of +1 mm.
- For sizes 305 to 472 the outer diameter of part 5 and part 7 is smaller than ØDA.
- Weights and mass moments of inertia apply to maximum bores.

Ordering example

- N-EUPEX HDS coupling, size 103, S = 100 mm
- Part 1: Bore D1 42H7 mm, keyway to DIN 6885-1 and set screw
- Part 5: Bore D2 32H7 mm, keyway to DIN 6885-1 and set screw
- Coupling micro-balanced G6.3 at 1500 rpm in accordance with half parallel key standard

Article no.: 2LC0110-3AC99-0AA0-Z L0X+M0T+W02+Y95  
Plain text to Y95: G=6.3;n=1500rpm

<sup>1)</sup> To identify complete item numbers specifying the available finish boring options and – if necessary – further order options, please use our configurators on [flender.com](http://flender.com).

↗ For online configuration on [flender.com](http://flender.com), click on the item no.

# SPARE AND WEAR PARTS

## Elastomer flexibles of the N-EUPEX series

NBR elastomer flexibles 80 ShoreA standard type			
Size	Article No. (flexible set for one coupling)	Number of flexibles per set	Weight per set kg
58	2LC0170-0WA00-0AA0	4	0.012
68	2LC0170-1WA00-0AA0	5	0.015
80	2LC0170-2WA00-0AA0	6	0.02
95	2LC0170-3WA00-0AA0	6	0.03
110	2LC0170-4WA00-0AA0	6	0.045
125	2LC0170-5WA00-0AA0	6	0.06
140	2LC0170-6WA00-0AA0	6	0.09
160	2LC0170-7WA00-0AA0	7	0.12
180	2LC0170-8WA00-0AA0	8	0.17
200	2LC0171-0WA00-0AA0	8	0.23
225	2LC0171-1WA00-0AA0	8	0.3
250	2LC0171-2WA00-0AA0	8	0.38
280	2LC0171-3WA00-0AA0	8	0.55
315	2LC0171-4WA00-0AA0	9	0.7
350	2LC0171-5WA00-0AA0	9	0.85
400	2LC0171-6WA00-0AA0	10	1.2
440	2LC0171-7WA00-0AA0	10	1.5
480	2LC0171-8WA00-0AA0	10	2.1
520	2LC0172-0WA00-0AA0	10	2.6
560	2LC0172-1WA00-0AA0	10	3.6
610	2LC0172-2WA00-0AA0	10	4.9
660	2LC0172-3WA00-0AA0	10	6.3
710	2LC0172-4WA00-0AA0	10	7.6

HP elastomer flexibles for type DK/DKS (two-joint)			
Size	Article No. (flexible set for one coupling)	Number of flexibles per set	Weight per set kg
68	2LC0170-1VD00-0AA0	10	0.03
80	2LC0170-2VD00-0AA0	12	0.04
95	2LC0170-3VD00-0AA0	12	0.06
110	2LC0170-4VD00-0AA0	12	0.09
125	2LC0170-5VD00-0AA0	12	0.12
140	2LC0170-6VD00-0AA0	12	0.18
160	2LC0170-7VD00-0AA0	14	0.24
180	2LC0170-8VD00-0AA0	16	0.34
200	2LC0171-0VD00-0AA0	16	0.46
225	2LC0171-1VD00-0AA0	16	0.6
250	2LC0171-2VD00-0AA0	16	0.8
280	2LC0171-3VD00-0AA0	16	1.1

### Notes

- The elastomer flexibles are wear parts. The service life depends on the operating conditions.

### Elastomer flexibles of the N-EUPEX DS series

NBR elastomer flexibles standard type			
Size	Article No. (flexible set for one coupling)	Number of flexibles per set	Weight per set kg
66	2LC0110-0WA00-0AA0	4	0.012
76	2LC0110-1WA00-0AA0	5	0.015
88	2LC0110-2WA00-0AA0	6	0.021
103	2LC0110-3WA00-0AA0	6	0.033
118	2LC0110-4WA00-0AA0	6	0.048
135	2LC0110-5WA00-0AA0	6	0.072
152	2LC0110-6WA00-0AA0	6	0.1
172	2LC0110-7WA00-0AA0	7	0.16
194	2LC0110-8WA00-0AA0	8	0.21
218	2LC0111-0WA00-0AA0	8	0.28
245	2LC0111-1WA00-0AA0	8	0.45
272	2LC0111-2WA00-0AA0	8	0.64
305	2LC0111-3WA00-0AA0	8	0.72
340	2LC0111-4WA00-0AA0	9	0.92
380	2LC0111-5WA00-0AA0	9	1.2
430	2LC0111-6WA00-0AA0	10	1.6
472	2LC0111-7WA00-0AA0	10	2.0
514	2LC0111-8WA00-0AA0	10	2.5
556	2LC0112-0WA00-0AA0	10	3.2

#### Notes

- The elastomer flexibles are wear parts. The service life depends on the operating conditions.

### Friction linings of the N-EUPEX type ERN

Friction linings, standard version			
Size	Article No. (set for one coupling)	Number of friction linings per set	Weight per set kg
80	2LC0170-2VK00-0AA0	2	0.05
95	2LC0170-3VK00-0AA0	2	0.06
110	2LC0170-4VK00-0AA0	2	0.06
125	2LC0170-5VK00-0AA0	2	0.10
140	2LC0170-6VK00-0AA0	2	0.12
160	2LC0170-7VK00-0AA0	2	0.12
180	2LC0170-8VK00-0AA0	2	0.23
200	2LC0171-0VK00-0AA0	2	0.34
225	2LC0171-1VK00-0AA0	2	0.34
250	2LC0171-2VK00-0AA0	2	0.60
280	2LC0171-3VK00-0AA0	2	0.66

#### Notes

- The friction linings are wear parts. The service life depends on the operating conditions.



# FLEXIBLE COUPLINGS RUPEX SERIES

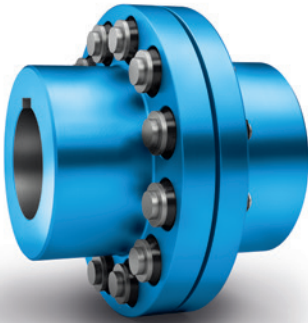

<b>General</b>	<b>8/3</b>
Benefits	8/3
Application	8/3
Design and configurations	8/4
Function	8/6
Technical specifications	8/6
-----	
Type RWN – Hub material grey cast iron	8/8
-----	
Type RWS – Hub material steel	8/10
-----	
Type RFN – Hub material grey cast iron	8/12
-----	
Type RFS – Hub material steel	8/14
-----	
Type RWB – with brake disk to DIN 15432	8/16
-----	
Type RBS – with brake disk to DIN 15432	8/18
-----	
Type RBS – with brake disk to DIN 15432	8/20
-----	
Type RWB – with brake drum to DIN 15431	8/22
-----	
Type RBS – with brake drum to DIN 15431	8/23
-----	
Spare and wear parts	8/24
-----	



RUPEX  
**FLENDER**



# GENERAL

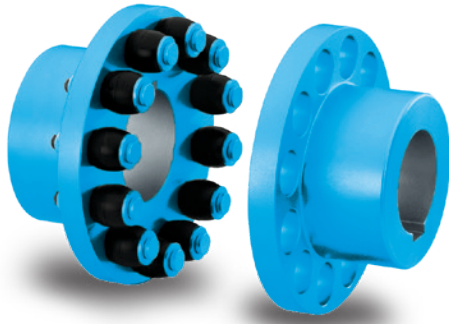

RUPEX pin and bush couplings link machine shafts and compensate for shaft misalignment with weak restorative forces. The torque is conducted through elastomer buffers, so the coupling has typically flexible rubber properties.

## Benefits

RUPEX couplings can also hold loads when overloaded and are therefore especially suitable for drives for special safety and reliability requirements.

Torque shock loads and changing loads are no problem for robust, compact flexible RUPEX couplings.

The steel variant is also especially suitable for high-speed drives.

## Application

RUPEX couplings are available as a catalog standard in 26 sizes with a rated torque of between 200 Nm and 1690000 Nm.

The coupling is suitable for use at ambient temperatures of between -30 °C and +80 °C. By using alternative elastomer buffers, the permissible ambient temperature range can be extended to between -50 °C and +100 °C.



Coupling suitable for use in potentially explosive atmospheres.

Complies with the current ATEX Directive for:

CE  II 2G Ex h IIC T6 ... T4 Gb X

 II 2D Ex h IIIC T85 °C ... 110 °C Db X

 I M2 Ex h Mb X

Thanks to their robust design, RUPEX couplings are also suitable for rough operating conditions.

RUPEX couplings are fitted by putting together the coupling halves. Fitting with low torsional backlash is simplified by the barrel-shaped geometry of the buffers.

RUPEX couplings require little maintenance. Only the elastomer buffers, as wear parts, need be replaced and the coupled machines need not be moved to do so.

RUPEX couplings are suitable for reversing operation and horizontal and vertical fitting or fitting at any required angle.

Frequently, the coupling is used to connect the gear shaft to the driven machine. In the case of drives without gear units, the coupling is particularly suitable for operation in rough conditions or heavy-duty drives with electric motor drive. Ventilator drives with high ventilator mass and drives in the cement industry are typical applications.

Examples of particularly safety-relevant areas of application are cable railway drives, lifting gear for crane drives or escalator drives.

# GENERAL

## Design and configurations

A RUPEX coupling comprises two hub sections which are mounted on the machine shafts. The hub parts are connected positively by steel pins and elastomer buffers. The coupling can be fitted with add-on parts such as brake disks or brake drums.

Up to size 360, the pins and buffers are fitted on one side. From size 400 up, the pins and buffers are fitted in the hubs on alternate sides.

## Materials

- Hubs:  
Types RWN and RWB made of grey cast iron EN-GJL-250  
Types RWS and RBS made of steel
- Flange:  
Types RFN, RFS made of steel
- Pins:  
Material steel 42CrMo4, surface fine-machined

- Brake disks:  
Type RWB made of EN-GJS-400 spheroidal graphite cast iron  
Type RBS made of steel
- Brake drums:  
Type RWB made of EN-GJL-250 grey cast iron  
Type RBS made of steel

8

## Buffer material

Material/description	Hardness	Marking	Ambient temperature
<b>NBR standard type</b>	<b>80 ShoreA</b>	<b>Buffer black</b>	<b>-30 °C ... +80 °C</b>
NBR electrically insulating	80 ShoreA	Buffer green	-30 °C ... +80 °C
NBR soft	65 ShoreA	Buffer black with green dot	-30 °C ... +80 °C
NBR hard	90 ShoreA	Buffer black with magenta dot	-30 °C ... +80 °C
NR for low temperature	80 ShoreA	Buffer black with white dot	-50 °C ... +50 °C
HNBR high temperature	80 ShoreA	Buffer black with red dot	-10 °C ... +100 °C

## RUPEX pin and bush coupling types

Type	Description
<b>RWN</b>	Coupling made of grey cast iron
<b>RWS</b>	Coupling made of steel
<b>RWB</b>	Coupling made of grey cast iron with brake drum or brake disk
<b>RBS</b>	Coupling made of steel with brake drum or brake disk
<b>RFN</b>	Coupling made of grey cast iron in flange-shaft variant
<b>RFS</b>	Coupling made of steel in flange-shaft variant

Further application-related coupling types are available. Dimension sheets for and information on these are available on request.

## RUPEX pin and bush coupling types on request

Type	Description
<b>All</b>	Coupling with axial backlash limitation
	Coupling with pretensioned buffers
	Coupling with lengthened pins and spacer sleeves
<b>RKS</b>	Coupling for engaging/disengaging during standstill
<b>RWNH, RWSH</b>	Coupling with extension piece
<b>RBM</b>	Coupling with lengthened pins for sliding rotor motors
<b>RAK</b>	Coupling combination RUPEX with ARPEX all-steel membrane coupling



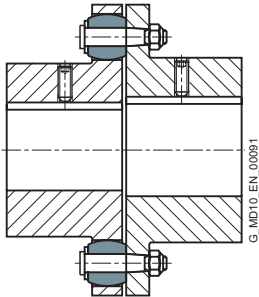

up to size 360

Types RWN/RWS – One-sided arrangement of pins and buffers

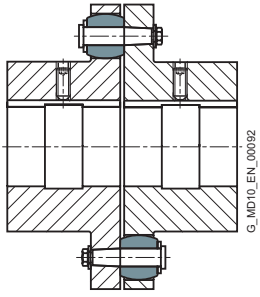

from size 400

Types RWN/RWS – Alternate-sided arrangement of pins and buffers

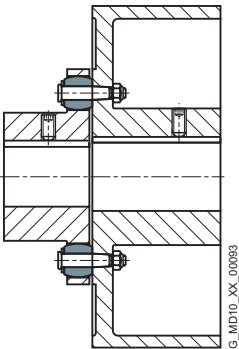

Types RWB/RBS with brake drum

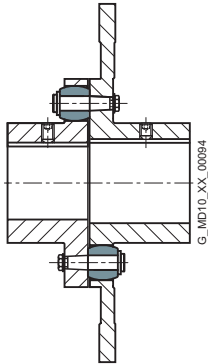

Types RWB/RBS with brake disk

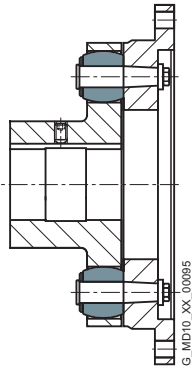

Types RFN, RFS

# GENERAL

## Function

The motor torque is transmitted to the hub on the drive side via the shaft-hub connection, which is mostly designed as a keyway connection. With the aid of elastomer buffers mounted on steel pins, the torque is conducted to the hub on the output side. The hub on the output side

further transmits the torque to the driven machine or a gear unit located in between. Because of the primarily compression-loaded buffers, the coupling has a progressive torsional stiffness.

## Technical specifications

Size	Rated torque for buffer type		Maximum torque for buffer type		Torsional stiffness at 50 % capacity utilization for buffer type			Assembly Gap dimension $\Delta S$ mm	Permitted shaft misalignment at $n = 1500$ rpm <sup>1)</sup>	
	65 ShoreA	80/90 ShoreA	65 ShoreA	80/90 ShoreA	65 ShoreA	80 ShoreA	90 ShoreA		Radial $\Delta K_r$ mm	Angle $\Delta K_w$ Degree
	$T_{KN}$ Nm	$T_{KN}^{2)}$ Nm	$T_{Kmax}$ Nm	$T_{Kmax}$ Nm	$C_{Tdyn 50\%}$ kNm/rad	$C_{Tdyn 50\%}$ kNm/rad	$C_{Tdyn 50\%}$ kNm/rad			
105	120	200	360	600	5	13	21	1	0.21	0.12
125	210	350	630	1050	9	25	37	1	0.23	0.11
144	300	500	900	1500	15	43	64	1	0.25	0.1
162	450	750	1350	2250	20	55	83	1.5	0.27	0.1
178	570	950	1710	2850	31	85	130	1.5	0.29	0.09
198	780	1300	2340	3900	43	123	187	1.5	0.3	0.09
228	1300	2200	3900	6600	65	184	270	1.5	0.34	0.09
252	1650	2750	4950	8250	92	256	380	1.5	0.36	0.08
285	2600	4300	7800	12900	141	390	560	1.5	0.4	0.08
320	3300	5500	9900	16500	195	540	790	1.5	0.43	0.08
360	4700	7800	14100	23400	276	610	940	1.5	0.48	0.08
400	7500	12500	22500	37500	410	1130	1710	1.5	0.52	0.07
450	11000	18500	33000	55500	570	1600	2380	1.5	0.57	0.07
500	15000	25000	45000	75000	860	2350	3600	1.5	0.62	0.07
560	23500	39000	70500	117000	1130	3070	4700	2	0.68	0.07
630	31000	52000	93000	156000	1640	4600	7400	2	0.75	0.07
710	50000	84000	150000	252000	2560	7200	10900	2	0.84	0.07
800	66000	110000	198000	330000	3900	10700	16700	2	0.93	0.07
900	90000	150000	270000	450000	5200	14300	22500	2.5	1.03	0.07
1000	115000	195000	345000	585000	7700	21300	33000	2.5	1.14	0.07
1120	160000	270000	480000	810000	9800	27300	44000	2.5	1.26	0.06
1250	205000	345000	615000	1035000	14000	39000	62000	2.5	1.39	0.06
1400	320000	530000	960000	1590000	22800	62000	97000	3	1.55	0.06
1600	450000	750000	1350000	2250000	37000	103000	160000	3	1.76	0.06
1800	585000	975000	1755000	2925000	48000	133000	208000	4	1.96	0.06
2000	780000	1300000	2340000	3900000	73000	201000	314000	4	2.17	0.06

For coupling fatigue torque:

$$T_{KW} = 0,20 \cdot T_{KN}$$

## Note

For fitting, the maximum gap dimension of  $S_{max.} = S + \Delta S$  and the minimum gap dimension of  $S_{min.} = S - \Delta S$  are permitted.

<sup>1)</sup> The maximum speed for the respective type must be noted.  
For additional information on the allowable shaft misalignment, please refer to the operating instructions.

<sup>2)</sup> Higher rated torque permitted for steel hubs with buffer version 90 Shore A. See information in the type tables for details.

### Torsional stiffness and damping

The values stated in the above table apply to a capacity utilization of 50 %, an excitation amplitude of 10 %  $T_{KN}$  with the frequency 10 Hz and an ambient temperature of 20 °C. The dynamic torsional stiffness is load-dependent and increases in proportion to capacity utilization. The following table shows the correction factors for different rated loads.

$$C_{Tdyn} = C_{Tdyn} 50 \% \cdot FKC$$

	Load $T_N / T_{KN}$							
	20%	40%	50%	60%	70%	80%	90%	100%
Correction factor FKC 65/80/90 ShoreA	0.51	0.83	1	1.18	1.38	1.58	1.8	2.03

### The damping coefficient is $\Psi = 1.4$

Torsional stiffness and damping is further dependent on the ambient temperature and the frequency and amplitude of the torsional vibration excitation. More precise torsional stiffness and damping parameters on request.

With flexible couplings the manufacturing process of the rubber elements and their aging primarily influence the stiffness value  $C_{Tdyn}$ . For this reason calculation must be made with a tolerance for the dynamic stiffness of  $\pm 20 \%$ . The specified damping coefficient  $\Psi$  is a minimum value with the result that the damping performance of the coupling corresponds at least to the specified value.

### Permitted shaft misalignment

The permitted shaft misalignment depends on the operating speed. As the speed increases, lower shaft misalignment values are permitted. The correction factors for different speeds are specified in the following table. The maximum speed for the respective coupling size and type must be noted!

$$\Delta K_{perm} = \Delta K_{1500} \cdot FKV$$

	Speed in rpm			
	500	1000	1500	3000
Correction factor FKV	1.7	1.2	1.0	0.7

For fitting, the maximum gap dimension of  $S_{max.} = S + \Delta S$  and the minimum gap dimension of  $S_{min.} = S - \Delta S$  are permitted.

Shaft misalignments  $\Delta K_r$  and  $\Delta K_w$  may occur simultaneously.

# TYPE RWN

Hub material grey cast iron

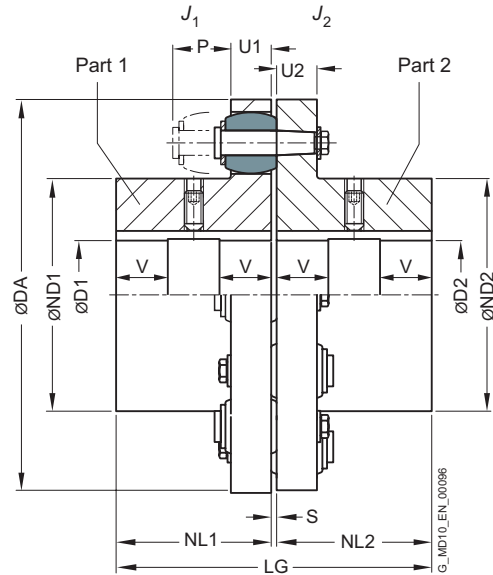

8

Size	Rated torque buffer 80 ShoreA $T_{KN}$ Nm	Speed $n_{Kmax}$ rpm	Dimensions in mm													Mass moment of inertia		Article no. <sup>1)</sup>	Weight  $m$ kg
			Bore with keyway DIN 6885-1 D1		D2		DA	ND1	ND2	NL1/ NL2	S	U1	U2	P	LG	$J_1$ kgm <sup>2</sup>	$J_2$ kgm <sup>2</sup>		
			min.	max.	min.	max.													
105 <sup>2)</sup>	200	7000	-	35	-	42	105	53	59	45	3	13	12	30	93	0.001	0.001	2LC0130-1AA	1.8
125 <sup>2)</sup>	350	6000	-	42	-	48	125	65	68	50	3	16	15	35	103	0.003	0.003	2LC0130-2AA	3.2
144	500	5250	-	48	-	60	144	76	84	55	3	16	15	35	113	0.004	0.006	2LC0130-3AA	4.2
162	750	4650	-	55	-	65	162	85	92	60	3.5	20	18	40	123.5	0.007	0.013	2LC0130-4AA	6.3
178	950	4200	-	70	-	75	178	102	108	70	3.5	20	18	40	143.5	0.013	0.022	2LC0130-5AA	8.9
198	1300	3750	-	80	-	90	198	120	128	80	3.5	20	18	40	163.5	0.021	0.029	2LC0130-6AA	11.5
228	2200	3300	-	90	-	95	228	129	140	90	3.5	26	24	50	183.5	0.036	0.070	2LC0130-7AA	17.7
252	2750	3000	-	100	-	110	252	150	160	100	3.5	26	24	50	203.5	0.068	0.12	2LC0130-8AA	24
285	4300	2650	48	110	48	120	285	164	175	110	4.5	32	30	60	224.5	0.13	0.22	2LC0131-0AA	36
320	5500	2350	55	120	55	130	320	180	192	125	4.5	32	30	60	254.5	0.22	0.29	2LC0131-1AA	50
360	7800	2100	65	130	65	140	360	200	210	140	4.5	42	42	75	284.5	0.40	0.69	2LC0131-2AA	74
400	12500	2050	75	150	75	150	400	230	230	160	4.5	42	42	75	324.5	0.86	0.86	2LC0131-3AA	100
450	18500	1800	85	170	85	170	450	260	260	180	5.5	52	52	90	365.5	1.7	1.7	2LC0131-4AA	149
500	25000	1600	95	190	95	190	500	290	290	200	5.5	52	52	90	405.5	2.8	2.8	2LC0131-5AA	192
560	39000	1500	100	140	100	140	560	250	250	220	6	68	68	120	446	4.6	4.6	2LC0131-6AA	280
			140	180	140	180		300	300							5	5		290
			180	200	180	200		320	320							5.1	5.1		295
630	52000	1280	100	140	100	140	630	250	250	240	6	68	68	120	486	7.2	7.2	2LC0131-7AA	345
			140	180	140	180		300	300							7.7	7.7		370
			180	220	180	220		355	355							8.4	8.4		400
710	84000	1150	110	160	110	160	710	290	290	260	7	80	80	140	527	13	13	2LC0131-8AA	510
			160	200	160	200		330	330							14	14		515
			200	240	200	240		385	385							15	15		540

### Configurable variants <sup>1)</sup>

- ØD1 Without finished bore  
With finished bore
- ØD2 Without finished bore  
With finished bore

<sup>1)</sup> To identify complete item numbers specifying the available finish boring options and – if necessary – further order options, please use our configurators on [flender.com](http://flender.com).

<sup>2)</sup> Hub material spheroidal graphite iron EN-GJS 400.

➤ For online configuration on [flender.com](http://flender.com), click on the item no.

Size	Rated torque buffer 80 ShoreA $T_{KN}$ Nm	Speed $n_{Kmax}$ rpm	Dimensions in mm												Mass moment of inertia		Article no. <sup>1)</sup>	Weight $m$ kg	
			Bore with keyway DIN 6885-1				DA	ND1	ND2	NL1/ NL2	S	U1	U2	P	LG	$J_1$ kgm <sup>2</sup>			$J_2$ kgm <sup>2</sup>
			min.	max.	min.	max.													
800	110000	1000	125	180	125	180	800	320	320	290	7	80	80	140	587	22	22	2LC0132-0AA	670
			180	220	180	220		360	360							23	23		690
			220	260	220	260		420	420							24.5	24.5		730
900	150000	900	140	220	140	220	900	360	360	320	7.5	90	90	160	647.5	39	39	2LC0132-1AA	940
			220	260	220	260		425	425							41	41		960
			260	290	260	290		465	465							43	43		1030
1000	195000	810	150	240	150	240	1000	395	395	350	7.5	90	90	160	707.5	60	60	2LC0132-2AA	1200
			240	280	240	280		460	460							63	63		1250
			280	320	280	320		515	515							68	68		1310
1120	270000	700	160	200	160	200	1120	360	360	380	8.5	100	100	180	768.5	98	98	2LC0132-3AA	1470
			200	250	200	250		410	410							100	100		1510
			250	300	250	300		495	495							105	105		1600
1250	345000	650	300	350	300	350	1250	560	560	420	8.5	100	100	180	848.5	110	110	2LC0132-4AA	1690
			180	230	180	230		410	410							150	150		1850
			230	280	230	280		460	460							155	155		1900
1400	530000	570	280	330	280	330	1400	540	540	480	9	120	120	210	969	165	165	2LC0132-5AA	2025
			330	380	330	380		610	610							175	175		2210
			200	260	200	260		465	465							290	290		2820
1600	750000	500	260	320	260	320	1600	525	525	540	9	120	120	210	1089	300	300	2LC0132-6AA	2900
			320	380	320	380		620	620							310	310		3180
			380	440	380	440		700	700							330	330		3260
1800	975000	450	440	480	440	480	1800	565	565	600	12	140	140	240	1212	490	490	2LC0132-7AA	3780
			320	380	320	380		625	625							500	500		3870
			380	440	380	440		720	720							530	530		4150
2000	1300000	400	440	500	440	500	2000	770	770	660	12	140	140	240	1332	550	550	2LC0132-8AA	4290
			320	380	320	380		660	660							850	850		5550
			380	440	380	440		720	720							930	930		5630
2000	1300000	400	440	500	440	500	2000	820	820	660	12	140	140	240	1332	980	980	2LC0132-8AA	6000
			500	560	500	560		870	870							1050	1050		6250
			560	600	560	600		920	920							1350	1350		6800
2000	1300000	400	560	600	560	600	2000	920	920	660	12	140	140	240	1332	1400	1400	2LC0132-8AA	7000
			560	600	560	600		960	960							1500	1500		7350
			560	600	560	600		960	960							1550	1550		7620

Configurable variants<sup>1)</sup>

- ØD1 Without finished bore  
With finished bore
- ØD2 Without finished bore  
With finished bore

Notes

- From size 560 bores D1 and D2 are each provided with a recess of D = +1 mm halfway along the hub.  $V \approx 1/3 NL$
- The hub diameter of the component part is assigned according to the diameter of the finished bore. Where bore diameters overlap, the component with the smaller hub diameter is always selected.
- Weight and mass moments of inertia apply to maximum bore diameters.
- The article numbers apply to standard buffers of NBR material in the 80 ShoreA variant; the article number for alternative buffer types is available on request.

Ordering example

- RUPEX RWN coupling, size 710
- Part 1: Hub left with bore 180H7 mm, with keyway to DIN 6885-1 and set screw
- Part 2: Hub right with bore 200H7 mm, with keyway to DIN 6885-1 and set screw.

Article no.: 2LC0131-8AA99-0AA0 L2B+M2D

<sup>1)</sup> To identify complete item numbers specifying the available finish boring options and – if necessary – further order options, please use our configurators on [flender.com](http://flender.com).

➤ For online configuration on [flender.com](http://flender.com), click on the item no.

# TYPE RWS

Hub material steel

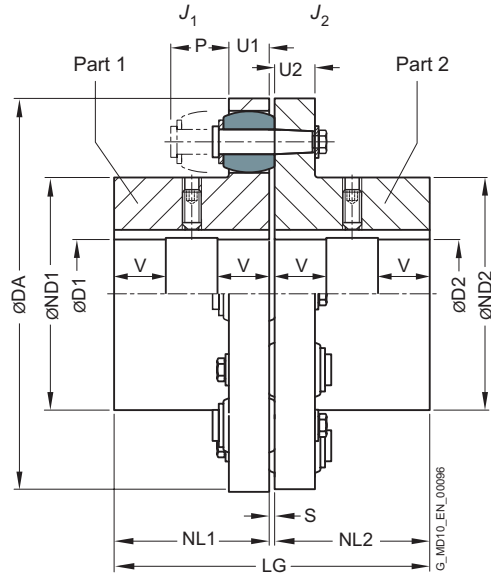

8

Size	Rated torque		Speed $n_{Kmax}$ rpm	Dimensions in mm													Mass moment of inertia		Article no. <sup>2)</sup>	Weight $m$ kg
	buffer 90 ShoreA $T_{KN}^{1)}$ Nm	buffer 80 ShoreA $T_{KN}$ Nm		Bore with keyway DIN 6885-1 D1				DA	ND1	ND2	NL1/ NL2	S	U1	U2	P	LG	$J_1$ kgm <sup>2</sup>	$J_2$ kgm <sup>2</sup>		
				min.	max.	min.	max.													
105	260	200	10000	-	38	-	42	105	53	59	45	3	13	12	30	93	0.001	0.001	2LC0130-1AB	1.7
125	450	350	9000	-	48	-	50	125	65	68	50	3	16	15	35	103	0.003	0.003	2LC0130-2AB	3.0
144	650	500	7800	-	55	-	60	144	76	84	55	3	16	15	35	113	0.004	0.006	2LC0130-3AB	4.3
162	950	750	6900	-	60	-	65	162	85	92	60	3.5	20	18	40	123.5	0.007	0.013	2LC0130-4AB	6.5
178	1200	950	6300	-	75	-	80	178	102	108	70	3.5	20	18	40	143.5	0.014	0.021	2LC0130-5AB	9.1
198	1700	1300	5600	-	90	-	95	198	120	128	80	3.5	20	18	40	163.5	0.020	0.028	2LC0130-6AB	11.2
228	2850	2200	4900	-	95	-	100	228	129	140	90	3.5	26	24	50	183.5	0.036	0.070	2LC0130-7AB	17.5
252	3550	2750	4400	-	110	-	120	252	150	160	100	3.5	26	24	50	203.5	0.066	0.115	2LC0130-8AB	23.6
285	5600	4300	3900	-	120	-	130	285	164	175	110	4.5	32	30	60	224.5	0.12	0.21	2LC0131-0AB	36
320	7150	5500	3500	55	130	55	140	320	180	192	125	4.5	32	30	60	254.5	0.23	0.29	2LC0131-1AB	50
360	10000	7800	3100	65	145	65	150	360	200	210	140	4.5	42	42	75	284.5	0.40	0.69	2LC0131-2AB	73
400	16000	12500	2800	75	170	75	170	400	230	230	160	4.5	42	42	75	324.5	0.83	0.83	2LC0131-3AB	97
450	24000	18500	2500	85	190	85	190	450	260	260	180	5.5	52	52	90	365.5	1.6	1.6	2LC0131-4AB	147
500	32500	25000	2200	95	215	95	215	500	290	290	200	5.5	52	52	90	405.5	2.7	2.7	2LC0131-5AB	192
560	50500	39000	2000	100	165	100	165		250	250							4.8	4.8	2LC0131-6AB	274
				165	200	165	200	560	300	300	220	6	68	68	120	446	5.2	5.2		292
				200	240	200	240		320	320							5.2	5.2		268
630	67500	52000	1800	100	165	100	165		250	250							7.6	7.6	2LC0131-7AB	352
				165	200	165	200	630	300	300	240	6	68	68	120	486	7.9	7.9		370
				200	265	200	265		355	355							8.4	8.4		356
710	109000	84000	1600	110	190	110	190		290	290							14.4	14.4	2LC0131-8AB	507
				190	220	190	220	710	330	330	260	7	80	80	140	527	14.6	14.6		530
				220	280	220	280		385	385							15.5	15.5		509

### Configurable variants <sup>2)</sup>

- ØD1 Without finished bore  
With finished bore
- ØD2 Without finished bore  
With finished bore

<sup>1)</sup>  $T_{Kmax}$  is given in the specifications on Page 8/6.  
 $T_{KW}$  is determined from the specifications given on Page 8/6.

<sup>2)</sup> To identify complete item numbers specifying the available finish boring options and – if necessary – further order options, please use our configurators on [flender.com](http://flender.com).

↗ For online configuration on [flender.com](http://flender.com), click on the item no.

Size	Rated torque		Speed $n_{Kmax}$ rpm	Dimensions in mm											Mass moment of inertia		Article no. <sup>2)</sup>	Weight $m$ kg		
	buffer 90 ShoreA $T_{KN}^{1)}$ Nm	buffer 80 ShoreA $T_{KN}$ Nm		Bore with keyway DIN 6885-1				DA	ND1	ND2	NL1/ NL2	S	U1	U2	P	LG			$J_1$ kgm <sup>2</sup>	$J_2$ kgm <sup>2</sup>
	D1			D2		min.	max.													
800	143000	110000	1400	125	210	125	210	800	320	320	290	7	80	80	140	587	23.1	23.1	2LC0132-0AB	683
				210	240	210	240		360	360							23.3	23.3		715
				240	310	240	310		420	420							25.0	25.0		699
900	195000	150000	1250	140	210	140	210	900	320	320	320	7.5	90	90	160	647.5	40	40	2LC0132-1AB	907
				210	240	210	240		360	360							41	41		933
				240	280	240	280		425	425							44	44		1000
				280	340	280	340		465	465							44	44		948
1000	250000	195000	1100	150	230	150	230	1000	355	355	350	7.5	90	90	160	707.5	63	63	2LC0132-2AB	1170
				230	260	230	260		395	395							64	64		1208
				260	300	260	300		460	460							68	68		1290
				300	380	300	380		515	515							68	68		1220
1120	350000	270000	1000	160	240	160	240	1120	360	360	380	8.5	100	100	180	768.5	105	105	2LC0132-3AB	1560
				240	270	240	270		410	410							106	106		1660
				270	330	270	330		495	495							109	109		1730
				330	410	330	410		560	560							116	116		1720
1250	450000	345000	900	180	270	180	270	1250	410	410	420	8.5	100	100	180	848.5	168	168	2LC0132-4AB	2000
				270	300	270	300		460	460							172	172		2150
				300	360	300	360		540	540							179	179		2200
				360	440	360	440		610	610							185	185		2250
1400	690000	530000	800	200	310	200	310	1400	465	465	480	9	120	120	210	969	316	316	2LC0132-5AB	3020
				310	350	310	350		525	525							322	322		3120
				350	410	350	410		620	620							337	337		3350
				410	510	410	510		700	700							349	349		3280
1600	975000	750000	700	260	370	260	370	1600	565	565	540	9	120	120	210	1089	540	540	2LC0132-6AB	3890
				370	410	370	410		625	625							554	554		4270
				410	480	410	480		720	720							587	587		4300
				480	560	480	560		770	770							598	598		4270
1800	1260000	975000	600	320	440	320	440	1800	660	660	600	12	140	140	240	1212	1043	1043	2LC0132-7AB	6230
				440	480	440	480		720	720							1072	1072		6460
				480	540	480	540		820	820							1122	1122		6770
				540	650	540	650		870	870							1113	1113		6390
2000	1690000	1300000	550	380	500	380	500	2000	760	760	660	12	140	140	240	1332	1628	1628	2LC0132-8AB	8140
				500	540	500	540		820	820							1664	1664		8430
				540	610	540	610		920	920							1735	1735		8860
				610	710	610	710		960	960							1749	1749		8280

Configurable variants<sup>2)</sup>

- ØD1 Without finished bore  
With finished bore
- ØD2 Without finished bore  
With finished bore

Notes

- From size 560 bores D1 and D2 are each provided with a recess of D = +1 mm halfway along the hub. V ≈ 1/3 NL
- The hub diameter of the component part is assigned according to the diameter of the finished bore. Where bore diameters overlap, the component with the smaller hub diameter is always selected.
- Weight and mass moments of inertia apply to maximum bore diameters.
- The article numbers apply to standard buffers of NBR material in the 80 ShoreA variant; the article number for alternative buffer types is available on request.

Ordering example

- RUPEX RWS coupling, size 710
- Part 1: Hub left with bore 180H7 mm, with keyway to DIN 6885-1 and set screw
- Part 2: Hub right with bore 200H7 mm, with keyway to DIN 6885-1 and set screw.
- Coupling micro-balanced G 6.3 at 1500 rpm in accordance with half parallel key standard

Article no.: 2LC0131-8AB99-0AA0-Z L2B+M2D+W02+Y95  
Plain text to Y95: G=6.3;n=1500rpm

<sup>1)</sup>  $T_{Kmax}$  is given in the specifications on Page 8/6.  
 $T_{KW}$  is determined from the specifications given on Page 8/6.

<sup>2)</sup> To identify complete item numbers specifying the available finish boring options and – if necessary – further order options, please use our configurators on [flieder.com](http://flieder.com).

↗ For online configuration on [flieder.com](http://flieder.com), click on the item no.

# TYPE RFN

Hub material grey cast iron

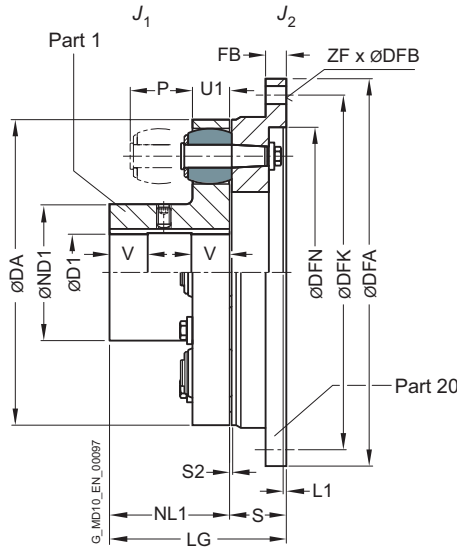

8

Size	Rated torque buffer 80 ShoreA $T_{KN}$ Nm	Speed $n_{Kmax}$ rpm	Dimensions in mm													Mass moment of inertia		Article no. <sup>1)</sup>	Weight $m$ kg		
			Bore with keyway DIN 6885-1 D1 min.   max.		DA	ND1	NL1	S	LG	Flange connection						$J_1$ kgm <sup>2</sup>	$J_2$ kgm <sup>2</sup>				
											DA	FB	DFN	L1	DFK	ZF	DFB				
105	200	7000	-	35	105	53	45	26	71	158	10				142	6	9	0.001	0.005	2LC0130-1AJ	2.2
125	350	6000	-	42	125	65	50	31	81	180	13				160	6	11	0.003	0.012	2LC0130-2AJ	4.1
144	500	5250	-	48	144	76	55	31	86	200	13				180	7	11	0.004	0.018	2LC0130-3AJ	4.9
162	750	4650	-	55	162	85	60	37.5	97.5	220	13				200	8	11	0.007	0.032	2LC0130-4AJ	7.1
178	950	4200	-	70	178	102	70	37.5	107.5	248	16				224	8	14	0.013	0.055	2LC0130-5AJ	9
198	1300	3750	-	80	198	120	80	37.5	117.5	274	16				250	8	14	0.021	0.08	2LC0130-6AJ	12
228	2200	3300	-	90	228	129	90	45.5	135.5	314	20				282	8	18	0.036	0.18	2LC0130-7AJ	19
252	2750	3000	-	100	252	150	100	45.5	145.5	344	20				312	8	18	0.068	0.26	2LC0130-8AJ	24
285	4300	2650	48	110	285	164	110	55.5	165.5	380	22				348	9	18	0.13	0.46	2LC0131-0AJ	37
320	5500	2350	55	120	320	180	125	55.5	175.5	430	25				390	9	22	0.22	0.76	2LC0131-1AJ	48
360	7800	2100	65	130	360	200	140	70.5	210.5	480	25				440	10	22	0.40	1.4	2LC0131-2AJ	74
400	12500	2050	75	150	400	230	160	74.5	234.5	520	50	380	4	480	10	22	0.86	1.8	2LC0131-3AJ	122	
450	18500	1800	85	170	450	260	180	85.5	265.5	575	45	428	6	528	12	26	1.7	3.2	2LC0131-4AJ	166	
500	25000	1600	95	190	500	290	200	85.5	285.5	620	45	475	6	570	12	26	2.8	4.3	2LC0131-5AJ	200	

### Configurable variants <sup>1)</sup>

- ØD1 Without finished bore  
With finished bore

<sup>1)</sup> To identify complete item numbers specifying the available finish boring options and – if necessary – further order options, please use our configurators on [flender.com](http://flender.com).

↗ For online configuration on [flender.com](http://flender.com), click on the item no.



Size	Rated torque buffer 80 ShoreA	Speed	Dimensions in mm													Mass moment of inertia		Article no. <sup>1)</sup>	Weight		
			Bore with keyway DIN 6885-1		DA	ND1	NL1	S	LG	Flange connection						J <sub>1</sub> kgm <sup>2</sup>	J <sub>2</sub> kgm <sup>2</sup>			m kg	
T <sub>KN</sub> Nm	n <sub>Kmax</sub> rpm	D1 min.	D1 max.	DFN h8						FB	DFN H7	L1	DFK	ZF	DFB			DFN h8	FB		DFN H7
560	39000	1500	100	140	560	250	220	106	326	700	65	532	8	650	16	26	4.6	8.2	2LC0131-6AJ	330	
			140	180		300											320			5	330
			180	200		320											5.1			340	
630	52000	1280	100	140	630	250	240	106	346	785	60	602	8	725	16	33	7.2	13.8	2LC0131-7AJ	390	
			140	180		300											355			7.7	400
			180	220		355											8.4			420	
710	84000	1150	110	160	710	290	260	127	387	875	80	675	10	815	18	33	13	26	2LC0131-8AJ	550	
			160	200		330											385			14	550
			200	240		385											15			570	
800	110000	1000	125	180	800	320	290	127	417	1000	70	765	10	930	16	39	22	45	2LC0131-9AJ	680	
			180	220		360											23			690	
			220	260		420											24.5			710	

Configurable variants <sup>1)</sup>

- ØD1 Without finished bore  
With finished bore

Notes

- For dimensions U1, P and S2, see type RWN on Page 8/8
- From size 560 bore D1 is provided with a recess of D = +1 mm halfway along the hub.  
V ≈ 1/3 NL
- Weight and mass moments of inertia apply to maximum bore diameters.
- The article numbers apply to standard buffers of NBR material in the 80 ShoreA variant; the article number for alternative buffer types is available on request.

Ordering example

- RUPEX RFN coupling, size 560
- Part 1: Hub left with bore 180H7 mm, with keyway to DIN 6885-1 and set screw

Article no.: 2LC0131-6AJ91-0AA0 L2B

<sup>1)</sup> To identify complete item numbers specifying the available finish boring options and – if necessary – further order options, please use our configurators on [flender.com](http://flender.com).

↗ For online configuration on [flender.com](http://flender.com), click on the item no.

# TYPE RFS

Hub material steel

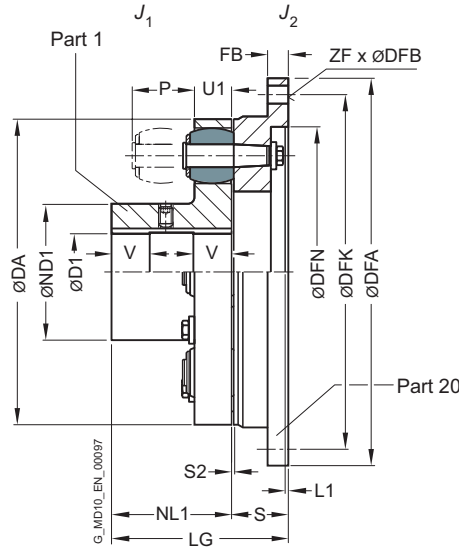

8

Size	Rated torque		Speed	Dimensions in mm													Mass moment of inertia		Article no. <sup>2)</sup>	Weight	
	buffer 90 ShoreA	buffer 80 ShoreA		Bore with keyway DIN 6885-1					Flange connection								$J_1$	$J_2$			
	$T_{KN}^{1)}$ Nm	$T_{KN}$ Nm	$n_{Kmax}$ rpm	D1	DA	ND1	NL1	S	LG	DFA	FB	DFN	L1	DFK	ZF	DFB	$J_1$	$J_2$		$m$ kg	
				min.	max.					h8		H7				kgm <sup>2</sup>	kgm <sup>2</sup>				
105	260	200	10000	-	38	105	53	45	26	71	158	10		142	6	9	0.001	0.005	2LC0130-1AK	2.2	
125	450	350	9000	-	48	125	65	50	31	81	180	13		160	6	11	0.003	0.012	2LC0130-2AK	4.0	
144	650	500	7800	-	55	144	76	55	31	86	200	13		180	7	11	0.004	0.018	2LC0130-3AK	4.8	
162	950	750	6900	-	60	162	85	60	37.5	97.5	220	13		200	8	11	0.007	0.032	2LC0130-4AK	7.1	
178	1200	950	6300	-	75	178	102	70	37.5	107.5	248	16		224	8	14	0.014	0.055	2LC0130-5AK	10	
198	1700	1300	5600	-	90	198	120	80	37.5	117.5	274	16		250	8	14	0.020	0.08	2LC0130-6AK	12	
228	2850	2200	4900	-	95	228	129	90	45.5	135.5	314	20		282	8	18	0.036	0.18	2LC0130-7AK	19	
252	3550	2750	4400	-	110	252	150	100	45.5	145.5	344	20		312	8	18	0.066	0.26	2LC0130-8AK	24	
285	5600	4300	3900	48	120	285	164	110	55.5	165.5	380	22		348	9	18	0.12	0.46	2LC0131-0AK	36	
320	7150	5500	3500	55	130	320	180	125	55.5	175.5	430	25		390	9	22	0.23	0.76	2LC0131-1AK	49	
360	10000	7800	3100	65	145	360	200	140	70.5	210.5	480	25		440	10	22	0.40	1.4	2LC0131-2AK	74	
400	16000	12500	2800	75	170	400	230	160	74.5	234.5	520	50	380	4	480	10	22	0.83	1.8	2LC0131-3AK	119
450	24000	18500	2500	85	190	450	260	180	85.5	265.5	575	45	428	6	528	12	26	1.6	3.2	2LC0131-4AK	167
500	32500	25000	2200	95	215	500	290	200	85.5	285.5	620	45	475	6	570	12	26	2.7	4.3	2LC0131-5AK	198

### Configurable variants <sup>2)</sup>

- ØD1 Without finished bore  
With finished bore

<sup>1)</sup>  $T_{Kmax}$  is given in the specifications on Page 8/6.

$T_{KW}$  is determined from the specifications given on Page 8/6.

<sup>2)</sup> To identify complete item numbers specifying the available finish boring options and – if necessary – further order options, please use our configurators on [flender.com](http://flender.com).

↗ For online configuration on [flender.com](http://flender.com), click on the item no.

Size	Rated torque		Speed $n_{Kmax}$ rpm	Dimensions in mm														Mass moment of inertia		Article no. <sup>2)</sup>	Weight $m$ kg	
	buffer 90 ShoreA	buffer 80 ShoreA		Bore with keyway DIN 6885-1					Flange connection									$J_1$ kgm <sup>2</sup>	$J_2$ kgm <sup>2</sup>			
	$T_{KN}^{1)}$ Nm	$T_{KN}$ Nm		D1 min.	D1 max.	DA	ND1	NL1	S	LG	DFA h8	FB	DFN H7	L1	DFK	ZF	DFB					
560	50500	39000	2000	100	165	560	250	300	220	106	326	700	65	532	8	650	16	26	4.8	8.2	2LC0131-6AK	330
				165	200		320												5.2			340
				200	240		320												5.2			320
630	67500	52000	1800	100	165	630	250	300	240	106	346	785	60	602	8	725	16	33	7.6	13.8	2LC0131-7AK	390
				165	200		355												7.9			400
				200	265		355												8.4			400
710	109000	84000	1600	110	190	710	290	330	260	127	387	875	80	675	10	815	18	33	14.4	26	2LC0131-8AK	550
				190	220		385												14.6			560
				220	280		385												15.5			555
800	143000	110000	1400	125	210	800	320	360	290	127	417	1000	70	765	10	930	16	39	23.1	45	2LC0131-9AK	690
				210	240		420												23.3			710
				240	310		420												25.0			700

Configurable variants <sup>2)</sup>

- ØD1 Without finished bore  
With finished bore

Notes

- For dimensions U1, P and S2, see type RWS on Page 8/10
- From size 560 bore D1 is provided with a recess of D = +1 mm halfway along the hub.  
 $V \approx 1/3 NL$
- Weight and mass moments of inertia apply to maximum bore diameters.
- The article numbers apply to standard buffers of NBR material in the 80 ShoreA variant; the article number for alternative buffer types is available on request.

Ordering example

- RUPEX RFS coupling, size 560
- Part 1: Hub left with bore 180H7 mm, with keyway to DIN 6885-1 and set screw
- Coupling micro-balanced G 6.3 at 1500 rpm in accordance with half parallel key standard

Article no.: 2LC0131-6AK91-0AA0-Z L2B+W02+Y95  
Plain text to Y95: G=6.3;n=1500rpm

<sup>1)</sup>  $T_{Kmax}$  is given in the specifications on Page 8/6.  
 $T_{KW}$  is determined from the specifications given on Page 8/6.

<sup>2)</sup> To identify complete item numbers specifying the available finish boring options and – if necessary – further order options, please use our configurators on [flender.com](http://flender.com).

➤ For online configuration on [flender.com](http://flender.com), click on the item no.

# TYPE RWB

with brake disk to DIN 15432

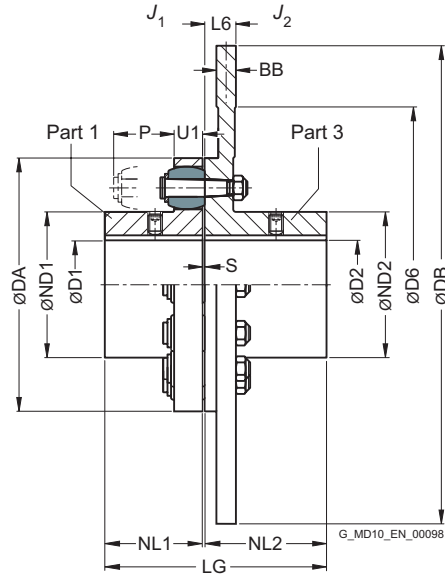

8

Size	Rated torque buffer 80 ShoreA  $T_{KN}$ Nm	Dimensions in mm																➤ Article no. <sup>1)</sup>		
		Bore with keyway DIN 6885-1				Shaft								Brake disk						
		D1 min.	D1 max.	D2 min.	D2 max.	DA	ND1	ND2	NL1	NL2 max.	S	U1	P	LG max.	DB <sup>2)</sup> max.	DB min.	D6 min.		BB <sup>2)</sup>	L6
144	500	-	48	-	45	144	76	84	55	219	3	16	35	277	500	315	175	30	34	2LC0130-3AE
162	750	-	55	-	50	162	85	92	60	219	3.5	20	40	282.5	560	315	175	30	34	2LC0130-4AE
178	950	-	70	-	60	178	102	108	70	219	3.5	20	40	292.5	560	355	200	30	34	2LC0130-5AE
198	1300	-	80	-	70	198	120	128	80	219	3.5	20	40	302.5	560	355	200	30	34	2LC0130-6AE
228	2200	-	90	-	80	228	129	140	90	219	3.5	26	50	312.5	800	355	250	30	34	2LC0130-7AE
252	2750	-	100	38	100	252	150	160	100	219	3.5	26	50	322.5	800	400	280	30	34	2LC0130-8AE
285	4300	48	110	48	110	285	164	175	110	219	4.5	32	60	333.5	800	400	310	30	34	2LC0131-0AE
320	5500	55	120	55	120	320	180	192	125	219	4.5	32	60	348.5	1000	450	350	30	34	2LC0131-1AE

## Configurable variants <sup>1)</sup>

- ØD1 Without finished bore  
With finished bore
- ØD2 With finished bore

<sup>1)</sup> To identify complete item numbers specifying the available finish boring options and – if necessary – further order options, please use our configurators on [flender.com](http://flender.com).

<sup>2)</sup> For the available DB · BB brake disk dimensions, please refer to the product configurator on [flender.com](http://flender.com).

➤ For online configuration on [flender.com](http://flender.com), click on the item no.

## Notes

---

- Brake disk diameter DB in accordance with customer specification.
  - Additional sizes are available on request.
  - Further dimensions for part 3 on request.
  - Maximum speed in rpm:  
 $n_{K_{max}} = 1146/DB$  (DB in m)  
 Observe maximum speed of type RWN!
  - Mass moments of inertia and weights can be sufficiently precisely determined as follows:
    - Mass moments of inertia in  $\text{kgm}^2$ :  
 $J_1 = J_1$  from type RWN  
 $J_2 = J_2$  from type RWN +  $710 \times BB \times DB^4$   
 (BB and DB in m)
    - Weight in kg:  
 $m = m$  from type RWN +  $5700 \times BB \times DB^2$   
 (BB and DB in m)
  - The article numbers apply to standard buffers of NBR material in the 80 ShoreA variant; the article number for alternative buffer types is available on request.
- 

## Ordering example

---

- RUPEX RWB coupling, size 252, brake disk 630 x 30 mm
  - Part 1: Bore D1 = 48H7 mm, keyway to DIN 6885-1 and set screw
  - Part 3: Bore 42H7 mm, keyway to DIN 6885-1 P9 and set screw.
  - Coupling micro-balanced G 6.3 at 1500 rpm in accordance with half parallel key standard
  - Mass moment of inertia:  
 $J_1 = 0.07 \text{ kgm}^2$   
 $J_2 = 0.12 \text{ kgm}^2 + 3.3 \text{ kgm}^2 = 3.42 \text{ kgm}^2$
  - Weight:  
 $m = 26.3 \text{ kg} + 68 \text{ kg} = 94.3 \text{ kg}$
- 

Article no.: 2LC0130-8AE99-0KA0-Z L1B+M0X+W02+Y95

Plain text to Y95: G=6.3;n=1500rpm

---

# TYPE RBS

with brake disk to DIN 15432

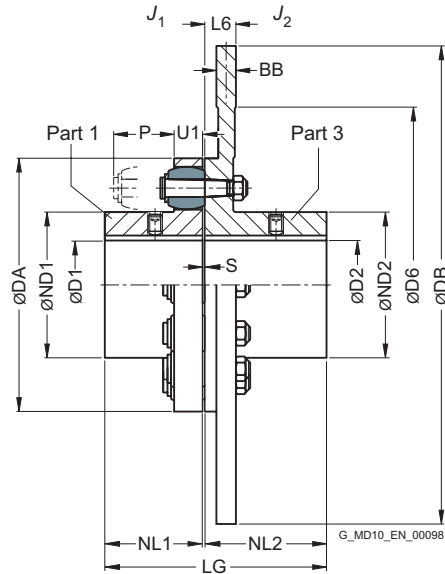

Size	Rated torque		Dimensions in mm																Article no. <sup>2)</sup>		
	buffer 90 ShoreA	buffer 80 ShoreA	Bore with keyway DIN 6885-1				Shaft										Brake disk				
	$T_{KN}^{1)}$ Nm	$T_{KN}$ Nm	D1 min.	D1 max.	D2 min.	D2 max.	DA	ND1	ND2	NL1	NL2 max.	S	U1	P	LG max.	DB <sup>3)</sup> min.	D6 min.	BB <sup>3)</sup>		L6	
144	650	500	-	55	-	45	144	76	84	55	219	3	16	35	277	315	175	30	34	2LC0130-3AH	
162	950	750	-	60	-	50	162	85	92	60	219	3.5	20	40	282.5	315	175	30	34	2LC0130-4AH	
178	1200	950	-	75	-	60	178	102	108	70	219	3.5	20	40	292.5	355	200	30	34	2LC0130-5AH	
198	1700	1300	-	90	-	70	198	120	128	80	219	3.5	20	40	302.5	355	200	30	34	2LC0130-6AH	
228	2850	2200	-	95	-	80	228	129	140	90	219	3.5	26	50	312.5	355	250	30	34	2LC0130-7AH	
252	3550	2750	-	110	38	100	252	150	160	100	219	3.5	26	50	322.5	400	280	30	34	2LC0130-8AH	
285	5600	4300	48	120	48	120	285	164	175	110	219	4.5	32	60	333.5	400	310	30	34	2LC0131-0AH	
320	7150	5500	55	130	55	130	320	180	192	125	219	4.5	32	60	348.5	450	350	30	34	2LC0131-1AH	
360	10000	7800	65	145	65	140	360	200	210	140	221	4.5	42	75	365.5	560	390	30	36	2LC0131-2AE	

### Configurable variants <sup>2)</sup>

- ØD1 Without finished bore  
With finished bore
- ØD2 With finished bore

<sup>1)</sup>  $T_{Kmax}$  is given in the specifications on Page 8/6.

$T_{KW}$  is determined from the specifications given on Page 8/6.

<sup>2)</sup> To identify complete item numbers specifying the available finish boring options and – if necessary – further order options, please use our configurators on [flender.com](http://flender.com).

<sup>3)</sup> For the available DB- BB brake disk dimensions, please refer to the product configurator on [flender.com](http://flender.com).

↗ For online configuration on [flender.com](http://flender.com), click on the item no.

## Notes

- Brake disk diameter DB in accordance with customer specification.
- Additional sizes are available on request.
- Further dimensions for part 3 on request.
- Maximum speed in rpm:  
 $n_{Kmax} = 1528/DB$  (DB in m)  
 Observe maximum speed of type RWS!
- Mass moments of inertia and weights can be sufficiently precisely determined as follows:
  - Mass moments of inertia in  $kgm^2$ :  
 $J_1 = J_1$  from type RWS  
 $J_2 = J_2$  from type RWS +  $770 \times BB \times DB^4$   
 (BB and DB in m)
  - Weight in kg:  
 $m = m$  from type RWS +  $6160 \times BB \times DB^2$   
 (BB and DB in m)
- The article numbers apply to standard buffers of NBR material in the 80 ShoreA variant; the article number for alternative buffer types is available on request.

## Ordering example

- RUPEX RBS coupling, size 252, brake disk 630 x 30 mm
- Part 1: Bore D1 = 48H7 mm, keyway to DIN 6885-1 and set screw
- Part 3: Bore 42H7 mm, keyway to DIN 6885-1 P9 and set screw.
- Coupling micro-balanced G 6.3 at 1500 rpm in accordance with the half parallel key standard.
- Mass moment of inertia:  
 $J_1 = 0.07 \text{ kgm}^2$   
 $J_2 = 0.12 \text{ kgm}^2 + 3.6 \text{ kgm}^2 = 3.72 \text{ kgm}^2$
- Weight:  
 $m = 25.8 \text{ kg} + 73 \text{ kg} = 98.8 \text{ kg}$

Article no.: 2LC0130-8AH99-0KA0-Z L1B+M0X+W02+Y95  
 Plain text to Y95: G=6.3;n=1500rpm

# TYPE RBS

with brake disk to DIN 15432

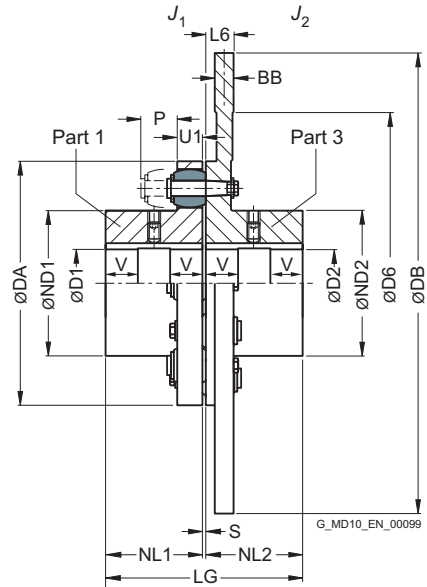

8

Size	Rated torque		Dimensions in mm													Brake disk			Article no. <sup>1)</sup>
	buffer 90 ShoreA $T_{KN}$ Nm	buffer 80 ShoreA $T_{KN}$ Nm	Bore with keyway DIN 6885-1				DA	ND1	ND2	NL1	NL2	S	U1	P	LG	D6 <sup>2)</sup> min.	BB <sup>2)</sup>	L6	
			D1 min.	D1 max.	D2 min.	D2 max.													
400	16000	12500	75	170	75	150	400	230	230	160	225	4.5	42	75	389.5	410	30	40	2LC0131-3AH
450	24000	18500	85	190	85	170	450	260	260	180	225	5.5	52	90	410.5	460	30	40	2LC0131-4AH
500	32500	25000	95	215	95	190	500	290	290	200	225	5.5	52	90	430.5	510	30	40	2LC0131-5AH
560	50500	39000	100	165	100	210	560	250	320	220	225	6	68	120	451	570	30	40	2LC0131-6AH
			200	240				320											
630	67500	52000	100	165	100	235	630	250	355	240	240	6	68	120	486	670	30	55	2LC0131-7AH
			200	265				355											

## Configurable variants <sup>1)</sup>

- ØD1 Without finished bore  
With finished bore
- ØD2 With finished bore

<sup>1)</sup> To identify complete item numbers specifying the available finish boring options and – if necessary – further order options, please use our configurators on [flender.com](http://flender.com).

<sup>2)</sup> For the available DB · BB brake disk dimensions, please refer to the product configurator on [flender.com](http://flender.com).

➤ For online configuration on [flender.com](http://flender.com), click on the item no.



Size	Rated torque		Dimensions in mm														Article no. <sup>1)</sup>		
	buffer 90 ShoreA	buffer 80 ShoreA	Bore with keyway DIN 6885-1												Brake disk				
	$T_{KN}$ Nm	$T_{KN}$ Nm	D1		D2		DA	ND1	ND2	NL1	NL2	S	U1	P	LG	D6 <sup>2)</sup> min.		BB <sup>2)</sup>	L6
		min.	max.	min.	max.														
710	109000	84000	110	190	110	250	710	290	385	260	260	7	80	140	527	760	30	75	2LC0131-8AH
			190	220				330											
			220	250				385											
800	143000	110000	125	210	125	280	800	320	420	290	290	7	80	140	587	840	30	75	2LC0132-0AH
			210	240				360											
			240	280				420											
900	195000	150000	140	210	140	310	900	320	465	320	-	7.5	90	160	647.5	950	30	75	2LC0132-1AH
			210	240				360											
			240	280				425											
1000	250000	195000	150	230	150	340	1000	355	515	350	-	7.5	90	160	707.5	1050	30	75	2LC0132-2AH
			230	260				395											
			260	300				460											
			300	340				515											

Configurable variants<sup>1)</sup>

- ØD1 Without finished bore  
With finished bore
- ØD2 With finished bore

Notes

- From size 560 bores D1 are provided with a recess of D = +1 mm halfway along the hub.  
 $V \approx 1/3 NL$
- Brake disk diameter DB in accordance with customer specification.
- Additional sizes are available on request. Further dimensions for part 3 on request.
- Maximum speed in rpm:  
 $n_{Kmax} = 1528/DB$  (DB in m)  
Observe maximum speed of type RWS!
- Mass moments of inertia and weights can be sufficiently precisely determined as follows:
  - Mass moments of inertia in kgm<sup>2</sup>:  
 $J_1 = J_1$  from type RWS  
 $J_2 = J_2$  from type RWS +  $770 \times BB \times DB^4$  (BB and DB in m)
  - Weight in kg:  
 $m = m$  from type RWS +  $6160 \times BB \times DB^2$  (BB and DB in m)
- The article numbers apply to standard buffers of NBR material in the 80 ShoreA variant; the article number for alternative buffer types is available on request.

Ordering example

- RUPEX RBS coupling, size 450, brake disk 900 x 30 mm
- Part 1: Bore D1 = 130H7 mm, keyway to DIN 6885-1 and set screw
- Part 3: Bore 120H7 mm, keyway to DIN 6885-1 P9 and set screw.
- Coupling micro-balanced G 6.3 at 1500 rpm in accordance with half parallel key standard
- Mass moment of inertia:  
 $J_1 = 1.74 \text{ kgm}^2$   
 $J_2 = 1.74 \text{ kgm}^2 + 15 \text{ kgm}^2 = 16.74 \text{ kgm}^2$
- Weight:  
 $m = 25.8 \text{ kg} + 149 \text{ kg} = 174.8 \text{ kg}$

Article no.: 2LC0131-4AH99-0NA0-Z L1U+M1S+W02+Y95  
Plain text to Y95: G=6.3;n=1500rpm

<sup>1)</sup> To identify complete item numbers specifying the available finish boring options and – if necessary – further order options, please use our configurators on [flender.com](http://flender.com).

<sup>2)</sup> For the available DB·BB brake disk dimensions, please refer to the product configurator on [flender.com](http://flender.com).

➤ For online configuration on [flender.com](http://flender.com), click on the item no.

# TYPE RWB

with brake drum to DIN 15431

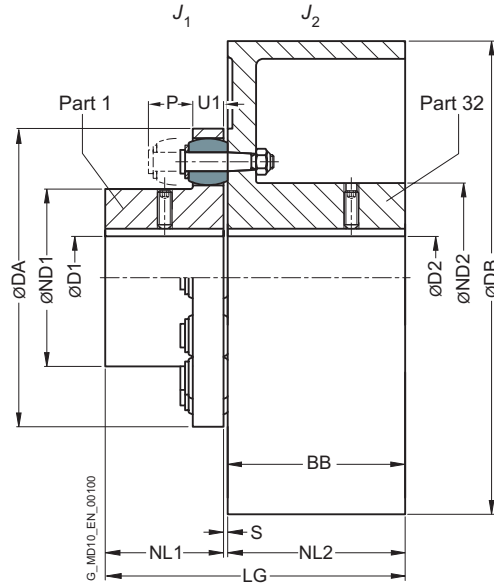

8

Size	Rated torque buffer 80 ShoreA $T_{KN}$ Nm	Speed $n_{Kmax}$ rpm	Dimensions in mm											Mass moment of inertia		Article no. <sup>1)</sup>	Weight $m$ kg		
			Bore with keyway DIN 6885-1			DA	ND1	ND2	NL1	NL2/BB	S	DB	LG	$J_1$	$J_2$				
			D1 min.	D1 max.	D2 min.	D2 max.													
144	500	4800	-	48	-	55	144	76	84	55	75	3	200	133	0.004	0.04	2LC0130-3AC	9.4	
162	750	3800	-	55	-	60	162	85	92	60	95	3.5	250	158.5	0.007	0.11	2LC0130-4AC	17	
		3000	-	70	-	70	178	102	108	70	95	3.5	250	168.5	0.013	0.12	2LC0130-5AC	19	
178	950	3800	-	70	-	70	178	102	108	70	95	3.5	250	168.5	0.013	0.12	2LC0130-5AC	19	
		3000	-	70	-	70	178	102	108	70	118	3.5	315	191.5	0.013	0.31	2LC0130-5AC	27	
198	1300	3800	-	80	-	80	198	120	128	80	95	3.5	250	178.5	0.021	0.13	2LC0130-6AC	23	
		3000	-	80	-	80	198	120	128	80	118	3.5	315	201.5	0.021	0.32	2LC0130-6AC	31	
228	2200	2400	-	90	-	90	228	129	140	90	150	3.5	400	243.5	0.036	1	2LC0130-7AC	53	
252	2750	2400	-	100	38	100	252	150	160	100	150	3.5	400	253.5	0.068	1	2LC0130-8AC	62	
		1900	-	100	38	100	252	150	160	100	190	3.5	500	293.5	0.068	2.8	2LC0130-8AC	92	
285	4300	1900	48	110	48	110	285	164	175	110	190	4.5	500	304.5	0.13	2.8	2LC0131-0AC	103	
		1500	48	110	48	110	285	164	175	110	236	4.5	630	350.5	0.13	7.8	2LC0131-0AC	156	
320	5500	1500	55	120	55	120	320	180	192	125	236	4.5	630	365.5	0.22	7.9	2LC0131-1AC	170	
		1300	55	120	55	120	320	180	192	125	265	4.5	710	394.5	0.22	13.9	2LC0131-1AC	215	
360	7800	1500	65	130	65	130	360	200	210	140	236	4.5	630	380.5	0.4	8.1	2LC0131-2AC	189	
		1300	65	130	65	130	360	200	210	140	265	4.5	710	409.5	0.4	14	2LC0131-2AC	234	

### Configurable variants <sup>1)</sup>

- ØD1 Without finished bore  
With finished bore
- ØD2 Without finished bore  
With finished bore

### Note

- For dimensions U1 and P, see type RWN on Page 8/8.
- Weight and mass moments of inertia apply to maximum bore diameters.
- The article numbers apply to standard buffers of NBR material in the 80 ShoreA variant; the article number for alternative buffer types is available on request.

### Ordering example

- RUPEX RWB coupling, size 252
- Part 1: Bore 48H7 mm, keyway to DIN 6885-1 and set screw
- Part 3: 500 x 190, bore 42H7 mm, keyway to DIN 6885-1 P9 and set screw.
- Coupling micro-balanced G 6.3 at 1500 rpm in accordance with half parallel key standard

Article no.: 2LC0130-8AC99-0FA0-Z L1B+M0X+W02+Y95  
Plain text to Y95: G=6.3;n=1500rpm

<sup>1)</sup> To identify complete item numbers specifying the available finish boring options and – if necessary – further order options, please use our configurators on [flender.com](http://flender.com).

➤ For online configuration on [flender.com](http://flender.com), click on the item no.

# TYPE RBS

with brake drum to DIN 15431

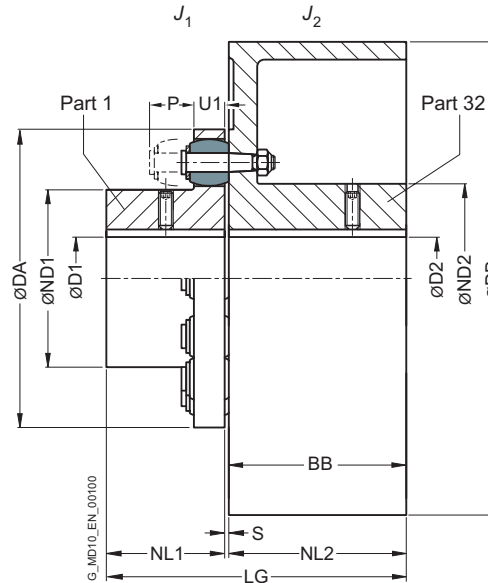

Size	Rated torque		Speed $n_{Kmax}$ rpm	Dimensions in mm												Mass moment of inertia		Article no. <sup>2)</sup>	Weight $m$ kg
	buffer 90 ShoreA $T_{KN}^{1)}$ Nm	buffer 80 ShoreA $T_{KN}$ Nm		Bore with keyway DIN 6885-1				DA	ND1	ND2	NL1	NL2/ BB	S	DB	LG	$J_1$ kgm <sup>2</sup>	$J_2$ kgm <sup>2</sup>		
	min.	max.		min.	max.	D1	D2												
144	650	500	7800	-	55	-	60	144	76	84	55	75	3	200	133	0.004	0.04	2LC0130-3AD	10
162	950	750	6900	-	60	-	65	162	85	92	60	95	3.5	250	158.5	0.007	0.13	2LC0130-4AD	18
178	1200	950	6300	-	75	-	75	178	102	108	70	95	3.5	250	168.5	0.014	0.13	2LC0130-5AD	22
			5500									315		191.5	0.34		2LC0130-5AD	30	
198	1700	1300	5600	-	90	-	85	198	120	128	80	95	3.5	250	178.5	0.020	0.14	2LC0130-6AD	26
			5500									315		201.5	0.35		2LC0130-6AD	35	
228	2850	2200	4300	-	95	-	95	228	129	140	90	150	3.5	400	243.5	0.036	1.1	2LC0130-7AD	60
252	3550	2750	4300	-	110	38	110	252	150	160	100	150	3.5	400	253.5	0.066	1.1	2LC0130-8AD	67
			3400				190					293.5		3.1	2LC0130-8AD		102		
285	5600	4300	3400	48	120	48	110	285	164	175	110	190	4.5	500	304.5	0.12	3.1	2LC0131-0AD	114
			2700				236					350.5		8.5	2LC0131-0AD		170		
320	7150	5500	2700	55	130	55	125	320	180	192	125	236	4.5	630	365.5	0.23	8.6	2LC0131-1AD	185
			2400				265					394.5		14.8	2LC0131-1AD		230		
360	10000	7800	2700	65	145	65	135	360	200	210	140	236	4.5	630	380.5	0.4	8.9	2LC0131-2AD	208
			2400				265					409.5		15.1	2LC0131-2AD		253		

## Configurable variants <sup>2)</sup>

- ØD1 Without finished bore  
With finished bore
- ØD2 Without finished bore  
With finished bore

## Note

- For dimensions U1 and P, see type RWS on Page 8/10.
- Weight and mass moments of inertia apply to maximum bore diameters.
- The article numbers apply to standard buffers of NBR material in the 80 ShoreA variant; the article number for alternative buffer types is available on request.

<sup>1)</sup>  $T_{Kmax}$  is given in the specifications on Page 8/6.  
 $T_{KW}$  is determined from the specifications given on Page 8/6.

## Ordering example

- RUPEX RBS coupling, size 252
- Part 1: Bore 48H7 mm, keyway to DIN 6885-1 and set screw
- Part 3: 500 x 190, bore 42H7 mm, keyway to DIN 6885-1 P9 and set screw
- Coupling micro-balanced G 6.3 at 1500 rpm in accordance with half parallel key standard

Article no.: 2LC0130-8AD99-0FA0-Z L1B+M0X+W02+Y95  
Plain text to Y95: G=6.3;n=1500rpm

<sup>2)</sup> To identify complete item numbers specifying the available finish boring options and – if necessary – further order options, please use our configurators on [flender.com](http://flender.com).

➤ For online configuration on [flender.com](http://flender.com), click on the item no.

# SPARE AND WEAR PARTS

## Buffers and pins

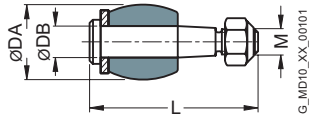

Sizes 105 to 400

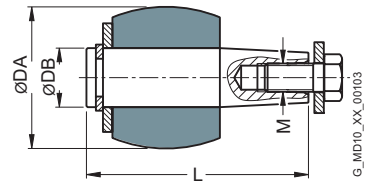

Sizes 710 to 2000

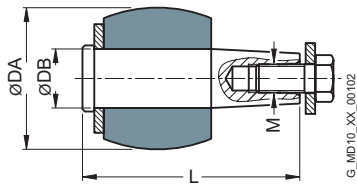

Sizes 450 to 630

Size	Marking	Number per set	Dimensions				Article No. for a set of buffers  [Buffer Perbunan 80ShoreA]	Weight  <i>m</i> kg	Article No. for a set of pins  [Pin complete, incl. fasteners]	Weight  <i>m</i> kg
			DA mm	DB mm	L mm	M				
105	105	8	20	8	45	M6	2LC0130-1WA00-0AA0	0.043	2LC0130-1WB00-0AA0	0.14
125	125	8	24	10	53.5	M8	2LC0130-2WA00-0AA0	0.098	2LC0130-2WB00-0AA0	0.28
144 <sup>1)</sup>	125	10	24	10	53.5 59.5	M8	2LC0130-3WA00-0AA0	0.12	2LC0130-3WB00-0AA0 ASE36074885	0.35 0.4
162 <sup>1)</sup>	162	9	30	12	64.5 67.5	M10	2LC0130-4WA00-0AA0	0.17	2LC0130-4WB00-0AA0 ASE36074964	0.57 0.6
178 <sup>1)</sup>	162	10	30	12	64.5 67.5	M10	2LC0130-5WA00-0AA0	0.19	2LC0130-5WB00-0AA0 ASE36075371	0.65 0.67
198 <sup>1)</sup>	162	12	30	12	64.5 67.5	M10	2LC0130-6WA00-0AA0	0.23	2LC0130-6WB00-0AA0 ASE36075396	0.76 0.8
228	228	11	40	16	79	M12	2LC0130-7WA00-0AA0	0.42	2LC0130-7WB00-0AA0	1.4
252	228	12	40	16	79	M12	2LC0130-8WA00-0AA0	0.45	2LC0130-8WB00-0AA0	1.5
285	285	11	48	20	98	M16	2LC0131-0WA00-0AA0	0.81	2LC0131-0WB00-0AA0	2.5
320	285	12	48	20	98	M16	2LC0131-1WA00-0AA0	0.88	2LC0131-1WB00-0AA0	2.8
360	360	10	64	25	123	M18	2LC0131-2WA00-0AA0	1.6	2LC0131-2WB00-0AA0	4.4
400	360	14	64	25	123	M18	2LC0131-3WA00-0AA0	2.2	2LC0131-3WB00-0AA0	6.1
450	450	12	78	32	123	M16	2LC0131-4WA00-0AA0	3.5	2LC0131-4WB00-0AA0	11
500	450	14	78	32	123	M16	2LC0131-5WA00-0AA0	4	2LC0131-5WB00-0AA0	13
560	560	12	101	42	158	M20	2LC0131-6WA00-0AA0	7.1	2LC0131-6WB00-0AA0	25
630	560	14	101	42	158	M20	2LC0131-7WA00-0AA0	8.3	2LC0131-7WB00-0AA0	29
710	710	14	120	50	185.5	M24	2LC0131-8WA00-0AA0	14	2LC0131-8WB00-0AA0	49
800	710	16	120	50	185.5	M24	2LC0132-0WA00-0AA0	16	2LC0132-0WB00-0AA0	56
900	900	16	136	55	207.5	M24	2LC0132-1WA00-0AA0	24	2LC0132-1WB00-0AA0	71
1000	900	18	136	55	207.5	M24	2LC0132-2WA00-0AA0	27	2LC0132-2WB00-0AA0	80
1120	1120	18	155	60	232.5	M30	2LC0132-3WA00-0AA0	41	2LC0132-3WB00-0AA0	110
1250	1120	20	155	60	232.5	M30	2LC0132-4WA00-0AA0	45	2LC0132-4WB00-0AA0	125
1400	1400	20	175	70	274	M30	2LC0132-5WA00-0AA0	65	2LC0132-5WB00-0AA0	185
1600	1400	24	175	70	274	M30	2LC0132-6WA00-0AA0	78	2LC0132-6WB00-0AA0	225
1800	1800	22	200	80	327	M36	2LC0132-7WA00-0AA0	115	2LC0132-7WB00-0AA0	320
2000	1800	26	200	80	327	M36	2LC0132-8WA00-0AA0	135	2LC0132-8WB00-0AA0	380

**Note**

- The buffers of RUPEX couplings are wear parts.  
The service life depends on the operating conditions.

<sup>1)</sup> For types RWB/RBS with brake disk BB = 30 only





# FLEXIBLE COUPLINGS N-BIPEX SERIES



<b>General</b>	<b>9/3</b>
Benefits	9/3
Application	9/4
Function	9/4
Design and configurations	9/5
Technical specifications	9/7
Assignment of N-BIPEX sizes to output PM of IEC standard motors	9/9
<b>Type BWN</b>	<b>9/10</b>
<b>Type BWT – Variant A</b>	<b>9/11</b>
<b>Type BWT – Variant B</b>	<b>9/12</b>
<b>Type BWT – Variant AB</b>	<b>9/13</b>
<b>Type BNT</b>	<b>9/14</b>
<b>Spare and wear parts</b>	<b>9/15</b>







# GENERAL

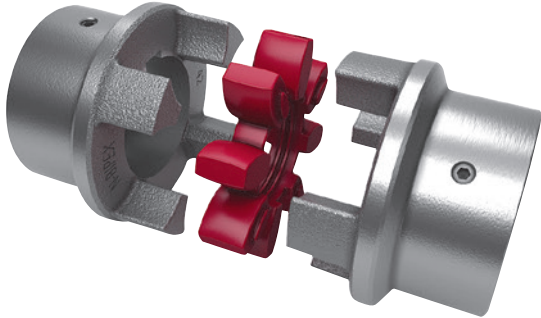

Coupling suitable for use in potentially explosive atmospheres.

Complies with the current ATEX Directive for:

CE  II 2G Ex h IIB T6 ... T4 Gb X

 II 2D Ex h IIIC T85 °C ... 120 °C Db X

 I M2 Ex h Mb X

N-BIPEX couplings are torsionally flexible and are outstanding for their particularly compact design and low weight.

N-BIPEX couplings are used in many areas of mechanical engineering.

Their main area of use is in electric motor drives which are well aligned and have uniform torque loads, such as in hydraulic applications and in combinations with geared motors.

## Benefits

N-BIPEX couplings are suitable for horizontal, vertical and freely selectable mounting positions. They are able to absorb axial, radial and angular misalignment.

N-BIPEX couplings consist of two identical hub parts which can be arranged as required on the shaft extensions to be connected. N-BIPEX couplings transmit the torque positively and are thus fail-safe. The curved design of the cast cams ensures that the N-BIPEX couplings have a perfect pressure distribution and this increases the elastomer lifetime.

The flexible cam rings responsible for torque transmission and misalignment compensation are available in different Shore hardnesses. As a result of the good damping capability and by selecting the suitable stiffness, torque shock loads can thus be absorbed and the torsional vibration behavior of the drive can be positively influenced.

Different cam ring versions and ready-to-install hub parts are available from stock.

# GENERAL

## Application

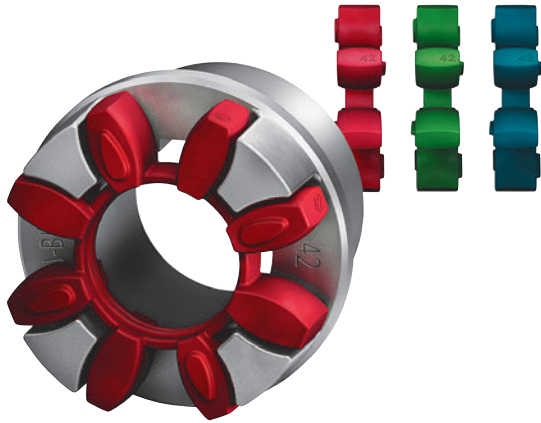

9

The N-BIPEX coupling is available as a catalog standard in 10 sizes with rated torques of between 12 Nm and 4650 Nm and is made of high-grade spheroidal graphite cast iron.

The extremely high-performance cam ring materials are available from stock in three different Shore hardnesses with the following colors:

- 92 ShoreA – red
- 95 ShoreA – green
- 64 ShoreD – blue

An additional size marking has been provided on the outer surface of the cam ring to be able to determine the size of the N-BIPEX even when it is in the assembled state without having to use any additional aids.

The coupling is suitable for use at ambient temperatures between -50 °C and +100 °C without any restrictions on the rated torque as a result of temperature factors.

## Function

The torque is transmitted to the hub at the drive end via the shaft-hub connection, which is mostly designed as a keyway connection, and is transmitted to the hub on the output side via the cam ring. This hub then further transmits the torque to the driven machine or a gear unit placed in between.

The special cam ring design helps to keep the compression-loaded cam ring elements in their defined position under all operating conditions and to keep them evenly loaded. This results in a long lifetime of the flexible elements.

A long lifetime is also guaranteed by the hub parts which ensure maximum operational reliability even under harsh operating conditions.

## Design and configurations

The N-BIPEX coupling of type BWN comprises two identical hub parts connected by a cam ring of elastomer material.

The hubs are connected to the respective shafts via finished bores with parallel keyway connection or Taper clamping bushes. N-BIPEX couplings are positive-locking and torsionally flexible thanks to the thermoplastic polyurethane cam ring.

### Coupling materials

#### Hubs:

- EN-GJS-400-15

#### Cam ring:

- TPU 92 ShoreA  
-50 °C to +100 °C without any restrictions
- TPU 95 ShoreA  
-50 °C to +100 °C without any restrictions
- TPU 64 ShoreD  
-50 °C to +100 °C without any restrictions.

The coupling comprises the following:

- Cam ring
- 2 hub parts with identical cams.

The hub parts are designed with a bore and keyway to DIN 6885-1 or with a taper bore for mounting a Taper clamping bush.

Fitting the clamping bush connects the hub firmly to the machine shaft.

In the case of part 4 the Taper clamping bush is inserted from the machine housing side. If there is insufficient space, the Taper clamping bush cannot be fitted from this side. Besides space for fitting the Taper clamping bush, space for the fitting tool (offset screwdriver) must be taken into consideration. In the case of part 3, the Taper clamping bush is screwed in from the shaft end face side. The hub must be fitted before the machines to be connected are pushed together.

### N-BIPEX coupling types

Type	Description
BWN	Coupling as a shaft-shaft connection with drilled and grooved hubs
BWT	Coupling as a shaft-shaft connection with Taper clamping bushes
BNT	Coupling as a shaft-shaft connection with drilled and grooved hubs and a Taper clamping bush

# GENERAL

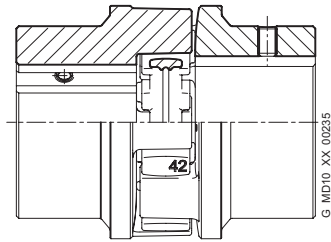

Type BWN

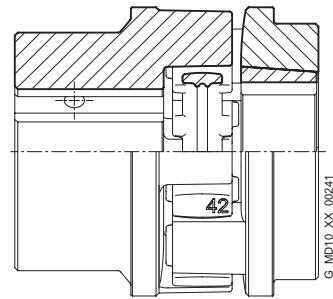

Type BNT

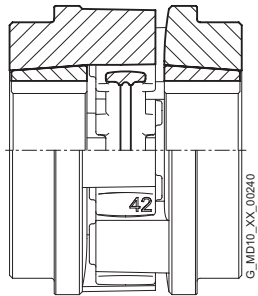

Type BWT

9

Size	Un-drilled	Preferred bores part 1/2 from stock with cylindrical finished bores $\emptyset$ in mm H7, parallel keyway according to DIN 6885-1 JS9 and set screw																																				
		10	11	12	14	15	16	17	18	19	20	22	24	25	28	30	32	35	38	40	42	45	48	50	55	60	65	70	75	80	85	90	100	110	120			
19																																						
24																																						
28																																						
38																																						
42																																						
48																																						
55																																						
65																																						
75																																						
90																																						

Preferred bores

## Technical specifications

Cam rings									
Size	Rated torque	Maximum torque	Fatigue torque	Maximum speed	Damping coefficient $\psi$	Torsional stiffness at 50 % capacity utilization	Permitted shaft misalignment at <sup>1)</sup>		
	$T_{KN}$ Nm	$T_{Kmax}$ Nm	$T_{KW}$ Nm	$V \leq 45$ m/s $n_{max}$ rpm		$C_{Tdyn 50\%}$ Nm/rad	< 10 Hz $\Delta K_a$ mm	n = 1500 rpm $\Delta K_r$ mm	$\Delta K_w$ degree
<b>Cam rings of polyurethane 92 ShoreA (standard)</b>									
19	12	36	2	19500	1.4	530	0.3	0.17	0.5
24	45	135	7	14500	1.4	1790	0.4	0.23	0.5
28	95	285	14	12500	1.4	3060	0.5	0.25	0.5
38	190	570	29	10000	1.4	6500	0.6	0.29	0.5
42	265	795	40	8500	1.4	8200	0.7	0.34	0.5
48	330	990	50	7500	1.4	10000	0.8	0.38	0.5
55	460	1380	70	6500	1.4	14500	0.9	0.4	0.5
65	670	2010	100	6000	1.4	25600	1	0.45	0.5
75	1400	4200	210	5000	1.4	37400	1.2	0.52	0.5
90	2500	7500	375	4000	1.4	62700	1.4	0.6	0.5
<b>Cam rings of polyurethane 95 ShoreA (ordering option -Z and order code K01)</b>									
19	18	54	3	19500	1.4	1130	0.27	0.15	0.4
24	65	195	10	14500	1.4	4240	0.36	0.21	0.4
28	160	480	25	12500	1.4	8050	0.45	0.23	0.4
38	325	975	50	10000	1.4	14100	0.54	0.26	0.4
42	450	1350	70	8500	1.4	16200	0.63	0.31	0.4
48	550	1650	85	7500	1.4	23300	0.72	0.34	0.4
55	700	2100	105	6500	1.4	28500	0.81	0.36	0.4
65	1000	3000	150	6000	1.4	35000	0.9	0.41	0.4
75	2000	6000	300	5000	1.4	66300	1.08	0.47	0.4
90	3700	11100	555	4000	1.4	105000	1.26	0.54	0.4
<b>Cam rings of polyurethane 64 ShoreD (ordering option -Z and order code K04)</b>									
19	25	75	5	19500	1.4	2010	0.24	0.14	0.3
24	90	270	15	14500	1.4	7680	0.32	0.18	0.3
28	200	600	30	12500	1.4	12200	0.4	0.2	0.3
38	405	1215	60	10000	1.4	25100	0.48	0.23	0.3
42	560	1680	84	8500	1.4	32000	0.56	0.27	0.3
48	700	2100	105	7500	1.4	41200	0.64	0.3	0.3
55	925	2775	140	6500	1.4	52600	0.72	0.32	0.3
65	1200	3600	180	6000	1.4	86700	0.8	0.36	0.3
75	2600	7800	390	5000	1.4	143000	0.96	0.42	0.3
90	4650	13950	700	4000	1.4	234000	1.12	0.48	0.3

<sup>1)</sup> The maximum speed must be observed. For further information on the allowable shaft misalignment, please refer to the operating instructions.

# GENERAL

## Torsional stiffness and damping

The values stated in the above table apply to a capacity utilization of 50 %, an excitation amplitude of 10 %  $T_{KN}$  with frequency 10 Hz and an ambient temperature of 20 °C. The dynamic torsional stiffness ( $C_{Tdyn}$ ) is load-dependent and increases in proportion to capacity utilization. The following table shows the correction factors for different nominal load.

$$C_{Tdyn} = C_{Tdyn} 50 \% \cdot FKC$$

	Load $T_N / T_{KN}$						
	20%	40%	50%	60%	70%	80%	100%
Correction factor FKC							
92/95 ShoreA and 64 ShoreD	0.56	0.85	1	1.17	1.35	1.53	1.92

Furthermore, torsional stiffness and damping depend on the ambient temperature, the frequency and the amplitude of the torsional vibration excitation. More precise torsional stiffness and damping parameters on request.

With flexible couplings the manufacturing process of the rubber elements and their aging primarily influence the stiffness value  $C_{Tdyn}$ . For this reason calculation must be made with a tolerance for the dynamic stiffness of  $\pm 20\%$ . The specified damping coefficient  $\Psi$  is a minimum value with the result that the damping performance of the coupling corresponds at least to the specified value.

## Permitted shaft misalignment

The permitted shaft misalignment depends on the operating speed. As the speed increases, lower shaft misalignment values are permitted. The correction factors for different speeds are specified in the following table. The maximum speed depending on the respective coupling size and type must be observed!

$$\Delta K_{perm} = \Delta K_{1500} \cdot FKV$$

	Speed in rpm			
	500	1000	1500	3000
Correction factor FKV	1.20	1.10	1.00	0.70

The axial misalignment may occur dynamically at frequencies up to 10 Hz.

For fitting, the maximum gap dimension of  $S2_{max.} = S2 + \Delta S2$  and the minimum gap dimension of  $S2_{min.} = S2 - \Delta S2$  are permitted.

The shaft misalignments  $\Delta K_a$ ,  $\Delta K_r$  and  $\Delta K_w$  may occur simultaneously (see Page E/10).

Assignment of N-BIPEX sizes to output PM of IEC standard motors <sup>1)</sup>

Three-phase motor Size	Motor output at $\approx 3000 \text{ min}^{-1}$		N-BIPEX coupling Size	Motor output at $\approx 1500 \text{ min}^{-1}$		N-BIPEX coupling Size	Motor output at $\approx 1000 \text{ min}^{-1}$		N-BIPEX coupling Size	Motor output at $\approx 750 \text{ min}^{-1}$		N-BIPEX coupling Size	DE shaft end D x E acc. to IEC	
	$P_M$ kW	T Nm		$P_M$ kW	T Nm		$P_M$ kW	T Nm		$P_M$ kW	T Nm		D mm	E mm
80	0.75	2.5	19	0.55	3.7	19	0.37	3.9	19	0.18	2.5	19	19	40
	1.1	3.7	19	0.75	5.1	19	0.55	5.8	19	0.25	3.5	19		
90S	1.5	5	19	1.1	7.5	19	0.75	8	19	0.37	5.3	19	19	40
90L	2.2	7.4	19	1.5	10	24	1.1	12	24	0.55	7.9	24	19	40
													24	50
100L	3	9.8	24	2.2	15	24	1.5	15	24	0.75	11	24	28	60
				3	20	24				1.1	16	24		
112M	4	13	24	4	27	24	2.2	22	24	1.5	21	24	28	60
132S	5.5	18	28	5.5	36	28	3	30	28	2.2	30	28	38	80
	7.5	25	28											
132M				7.5	49	28	4	40	28	3	40	28	38	80
							5.5	55	28					
160M	11	36	38	11	72	38	7.5	75	38	4	54	38	42	110
	15	49	38							5.5	74	38		
160L	18.5	60	38	15	98	38	11	109	38	7.5	100	38	42	110
180M	22	71	38	18.5	121	38							48	110
180L				22	144	38	15	148	42	11	145	42	48	110
200L	30	97	42	30	196	42	18.5	181	42	15	198	42	55	110
	37	120	42				22	215	42					
225S				37	240	48				18.5	244	48	60	140
225M	45	145	42										55	110
				45	292	55	30	293	55	22	290	55	60	140
250M	55	177	48										60	140
				55	356	55	37	361	55	30	392	65	65	140
280S	75	241	55										65	140
				75	484	65	45	438	65	37	483	65	75	140
280M	90	289	55										65	140
				90	581	75	55	535	75	45	587	75	75	140
315S	110	353	55										65	140
				110	707	75	75	727	75	55	712	75	80	170
315M	132	423	65										65	140
				132	849	75	90	873	75	75	971	75	80	170
315L	160	513	65										65	140
	200	641	75											
				160	1030	75	110	1070	75	90	1170	90	80	170
				200	1290	90	132	1280	90	110	1420	90		
315	250	802	75										65	140
	315	1010	90											
355				250	1600	90	200	1930	90				85	170
	355	1140	90										75	140
	400	1280	90										75	140
	500	1600	90										75	140
400	560	1790	90									80	170	

<sup>1)</sup> The assignment applies for an service factor of 1.25 and the use of a standard cam ring (92 ShoreA).

# TYPE BWN

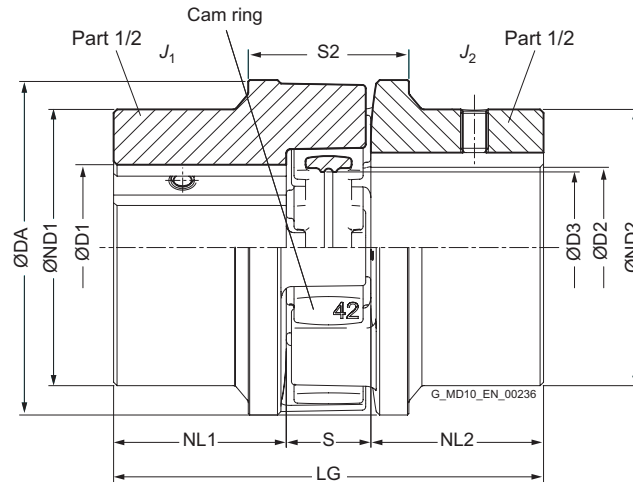

9

Size	Rated torque			Speed $n_{Kmax}$ rpm	Dimensions in mm										Mass moment of inertia $J_1/J_2$ kgm <sup>2</sup>	Article no. <sup>1)</sup>	Weight $m$ kg
	$T_{KN}$		64ShoreD Nm		D1/D2 Keyway DIN 6885 min.	DA	ND1/ ND2	NL1/ NL2	D3	S	S2	$\Delta S2$	LG				
	92 ShoreA Nm	95 ShoreA Nm												max.			
19	12	18	25	19500	0	25	42	38	25	17	16	31	1	66	0,000045	2LC0160-0AA	0.3
24	45	65	90	14500	0	35	55	55	30	25	18	-	1.5	78	0,0002	2LC0160-1AA	0.8
28	95	160	200	12500	0	40	67	58	35	28	20	41	1	90	0,00033	2LC0160-2AA	1
38	190	325	405	10000	0	48	82	68	45	36	24	45	1.5	114	0,0009	2LC0160-3AA	1.7
42	265	450	560	8500	0	55	97	80	50	43	26	48	1.5	126	0,0019	2LC0160-4AA	2.6
48	330	550	700	7500	0	62	107	90	56	48	28	50	2	140	0,0031	2LC0160-5AA	3.6
55	460	700	925	6500	0	75	120	110	65	57	30	86	2	160	0,008	2LC0160-6AA	6.7
65	670	1000	1200	6000	0	82	135	115	75	64	35	91	2.5	185	0,013	2LC0160-7AA	8.8
75	1400	2000	2600	5000	0	96	160	135	85	76	40	104	2.5	210	0,027	2LC0160-8AA	13.9
90	2500	3700	4650	4000	0	120	203	170	100	95	45	85	3	245	0,065	2LC0161-0AA	21.4

### Configurable variants <sup>1)</sup>

- ØD1 Without finished bore  
With finished bore
- ØD2 Without finished bore  
With finished bore
- Cam ring hardness **92 ShoreA**  
**95 ShoreA**  
**64 ShoreD**

### Notes

- Mass moments of inertia apply to a coupling half with maximum bore diameter.
- Weights apply to a whole coupling in the version with maximum bore.

### Ordering example

- N-BIPEX coupling BWN, size 42
- Part 1/2: Bore D1 42 H7 mm, with keyway to DIN 6885-1 and set screw
- Part 1/2: Bore D2 32 H7 mm, with keyway to DIN 6885-1 and set screw
- Cam ring hardness 92 ShoreA

Article no.: 2LC0160-4AA99-0AA0-Z L0X+M0T

<sup>1)</sup> To identify complete item numbers specifying the available finish boring options and – if necessary – further order options, please use our configurators on [flender.com](http://flender.com).

➤ For online configuration on [flender.com](http://flender.com), click on the item no.



# TYPE BWT

## Variant A

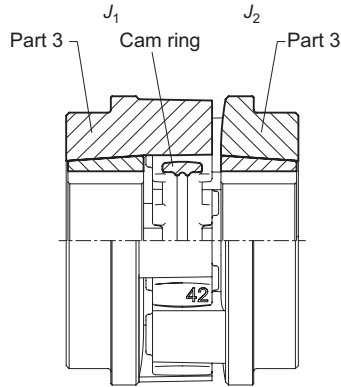

Variant A

Size	Taper Clamping Bush Size	Rated torque		Speed	Dimensions in mm										Mass moment of inertia $J_1/J_2$	Article no. <sup>1)</sup>	Weight		
		$T_{KN}$			$n_{Kmax}$	D1/D2 Keyway DIN 6885	DA	ND1/ND2	NL1/NL2	D3	S	S2	ΔS2	LG				Type	m
		92 ShoreA	95 ShoreA																
24	1008	45	65	14500	10	25	55	55	23	25	18	37	1.5	64	0.00016	2LC0160-1AB	0.6		
28	1108	95	160	12500	10	28	67	58	23	28	20	41	1	66	0.00025	2LC0160-2AB	0.8		
38	1108	190	325	10000	10	28	82	58	23	36	24	45	1.5	70	0.0005	2LC0160-3AB	1.2		
42	1610	265	450	8500	14	42	97	86	26	43	26	48	1.5	78	0.0013	2LC0160-4AB	1.8		
48	1615	330	550	7500	14	42	107	80	39	48	28	50	2	106	0.002	2LC0160-5AB	2.6		
55	2012	460	700	6500	14	50	120	100	33	57	30	60	2	96	0.004	2LC0160-6AB	3.9		
65	2012	670	1000	6000	14	50	135	100	33	64	35	65	2.5	101	0.007	2LC0160-7AB	5		
	55				60	115		46	127					0.008	5.9				
75	2517	1400	2000	5000	16	60	160	118	46	76	40	75	2.5	132	0.02	2LC0160-8AB	8.4		
	65				75	135		52	144					0.017	8.3				
90	3020	2500	3700	4000	25	75	205	142	52	95	45	85	3	149	0.037	2LC0161-0AB	12.9		
	80				90	170		90	225					0.06	19.8				

### Configurable variants <sup>1)</sup>

- ØD1 Without Taper clamping bush  
With Taper clamping bush
- ØD2 Without Taper clamping bush  
With Taper clamping bush
- Cam ring hardness **92 ShoreA**  
**95 ShoreA**

### Notes

- Mass moments of inertia apply to a coupling half without Taper clamping bush.
- Weights apply to a whole coupling in the version without Taper clamping bush.
- $T_{Kmax}$  for the 95 ShoreA cam ring is limited to  $2 \times T_{KN}$  for types BWT and BNT contrary to the table on Page 9/7. When using the 64 ShoreD cam ring, the same torque values apply as for the 95 ShoreA cam ring.

### Ordering example

- N-BIPEX BWT coupling, size 42, variant A
- Part 3: With Taper clamping bushes, size 1610, bore D1 38 H7 mm, with keyway to DIN 6885-1
- Part 4: With Taper clamping bushes, size 1610, bore D2 32 H7 mm, with keyway to DIN 6885-1
- Cam ring hardness 92 ShoreA

Article no.: 2LC0160-4AB99-0AA0-Z L0V+M0T

<sup>1)</sup> To identify complete item numbers specifying the available finish boring options and – if necessary – further order options, please use our configurators on [flender.com](http://flender.com).

<sup>2)</sup> Taper clamping bush version only possible in part 4.

➤ For online configuration on [flender.com](http://flender.com), click on the item no.

# TYPE BWT

## Variant B

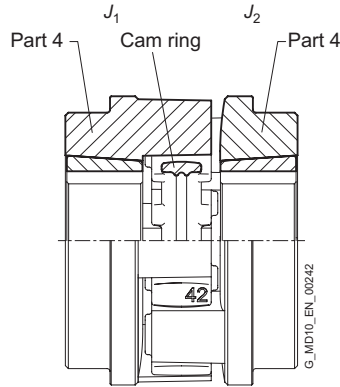

Variant B

Size	Taper Clamping Bush Size	Rated torque		Speed $n_{Kmax}$ rpm	Dimensions in mm										Mass moment of inertia $J_1/J_2$ kgm <sup>2</sup>	Article no. <sup>1)</sup> Type B	Weight $m$ kg
		$T_{KN}$			D1/D2 Keyway DIN 6885	DA	ND1/ ND2	NL1/ NL2	D3	S	S2	$\Delta S2$	LG				
		Nm	Nm											min.			
24	1008	45	65	14500	10	25	55	55	23	25	18	37	1.5	64	0.00016	2LC0160-1AC	0.6
28	1108	95	160	12500	10	28	67	58	23	28	20	41	1	66	0.00025	2LC0160-2AC	0.8
38	1108	190	325	10000	10	28	82	58	23	36	24	45	1.5	70	0.0005	2LC0160-3AC	1.2
42	1610	265	450	8500	14	42	97	86	26	43	26	48	1.5	78	0.0013	2LC0160-4AC	1.8
48	1615	330	550	7500	14	42	107	80	39	48	28	50	2	106	0.002	2LC0160-5AC	2.6
55	2012	460	700	6500	14	50	120	100	33	57	30	60	2	96	0.004	2LC0160-6AC	3.8
65	2012	670	1000	6000	14	50	135	100	33	64	35	65	2.5	101	0.007	2LC0160-7AC	5
	55				60	115								46	127		0.008
75	2517	1400	2000	5000	16	60	160	118	46	76	40	75	2.5	132	0.02	2LC0160-8AC	8.4
	3020 <sup>2)</sup>				65	75								135	52		144
90	3020	2500	3700	4000	25	75	205	142	52	95	45	85	3	149	0.037	2LC0161-0AC	12.9
	3535 <sup>2)</sup>				80	90								170	90		225

### Configurable variants <sup>1)</sup>

- $\varnothing D1$  Without Taper clamping bush  
With Taper clamping bush
- $\varnothing D2$  Without Taper clamping bush  
With Taper clamping bush
- Cam ring hardness **92 ShoreA**  
**95 ShoreA**

### Notes

- Mass moments of inertia apply to a coupling half without Taper clamping bush.
- Weights apply to a whole coupling in the version without taper clamping bush.
- $T_{Kmax}$  for the 95 ShoreA cam ring is limited to  $2 \times T_{KN}$  for types BWT and BNT contrary to the table on Page 9/7. When using the 64 ShoreD cam ring, the same torque values apply as for the 95 ShoreA cam ring.

### Ordering example

- N-BIPEX BWT coupling, size 42, variant B
- Part 3: With Taper clamping bushes, size 1610, bore D1 38 H7 mm, with keyway to DIN 6885-1
- Part 4: With Taper clamping bushes, size 1610, bore D2 32 H7 mm, with keyway to DIN 6885-1
- Cam ring hardness 92 ShoreA

Article no.: 2LC0160-4AC99-0AA0-Z L0V+M0T

<sup>1)</sup> To identify complete item numbers specifying the available finish boring options and – if necessary – further order options, please use our configurators on [flender.com](http://flender.com).

<sup>2)</sup> Taper clamping bush version only possible in part 4.

➤ For online configuration on [flender.com](http://flender.com), click on the item no.

# TYPE BWT

## Variant AB

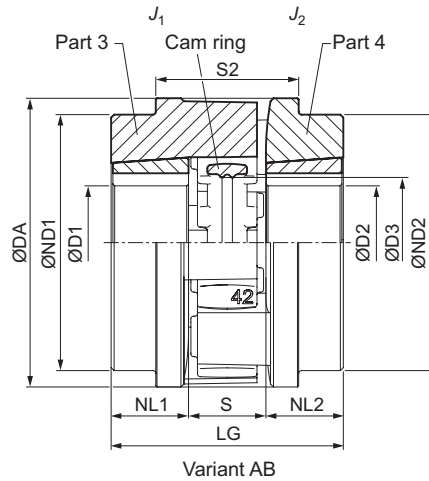

Size	Taper Clamping Bush Size	Rated torque		Speed $n_{Kmax}$ rpm	Dimensions in mm										Mass moment of inertia $J_1/J_2$ kgm <sup>2</sup>	Article no. <sup>1)</sup>	Weight  m kg
		$T_{KN}$			D1/D2 Keyway DIN 6885	DA	ND1/ ND2	NL1/ NL2	D3	S	S2	ΔS2	LG				
		92 ShoreA Nm	95 ShoreA Nm											min.			
24	1008	45	65	14500	10	25	55	55	23	25	18	37	1.5	64	0.00016	2LC0160-1AD	0.6
28	1108	95	160	12500	10	28	67	58	23	28	20	41	1	66	0.00025	2LC0160-2AD	0.8
38	1108	190	325	10000	10	28	82	58	23	36	24	45	1.5	70	0.0005	2LC0160-3AD	1.2
42	1610	265	450	8500	14	42	97	86	26	43	26	48	1.5	78	0.0013	2LC0160-4AD	1.8
48	1615	330	550	7500	14	42	107	80	39	48	28	50	2	106	0.002	2LC0160-5AD	2.6
55	2012	460	700	6500	14	50	120	100	33	57	30	60	2	96	0.004	2LC0160-6AD	3.9
65	2012	670	1000	6000	14	50	135	100	33	64	35	65	2.5	101	0.007	2LC0160-7AD	5
	2517 <sup>2)</sup>				55	60								115			46
75	2517	1400	2000	5000	16	60	160	118	46	76	40	75	2.5	132	0.015	2LC0160-8AD	8.4
	3020 <sup>2)</sup>				65	75								135			52
90	3020	2500	3700	4000	25	75	205	142	52	95	45	85	3	149	0.037	2LC0161-0AD	12.9
	3535 <sup>2)</sup>				80	90								170			90

### Configurable variants <sup>1)</sup>

- ØD1 Without Taper clamping bush  
With Taper clamping bush
- ØD2 Without Taper clamping bush  
With Taper clamping bush
- Cam ring hardness **92 ShoreA**  
**95 ShoreA**

### Notes

- Mass moments of inertia apply to a coupling half without Taper clamping bush.
- Weights apply to a whole coupling in the version without taper clamping bush.
- $T_{Kmax}$  for the 95 ShoreA cam ring is limited to  $2 \times T_{KN}$  for types BWT and BNT contrary to the table on Page 9/7. When using the 64 ShoreD cam ring, the same torque values apply as for the 95 ShoreA cam ring.

### Ordering example

- N-BIPEX BWT coupling, size 42, variant AB
- Part 3: With Taper clamping bushes, size 1610, bore D1 38 H7 mm, with keyway to DIN 6885-1
- Part 4: With Taper clamping bushes, size 1610, bore D2 32 H7 mm, with keyway to DIN 6885-1
- Cam ring hardness 92 ShoreA

Article no.: 2LC0160-4AD99-0AA0-Z L0V+M0T

<sup>1)</sup> To identify complete item numbers specifying the available finish boring options and – if necessary – further order options, please use our configurators on [flender.com](http://flender.com).

<sup>2)</sup> Taper clamping bush version only possible in part 4.

➤ For online configuration on [flender.com](http://flender.com), click on the item no.

# TYPE BNT

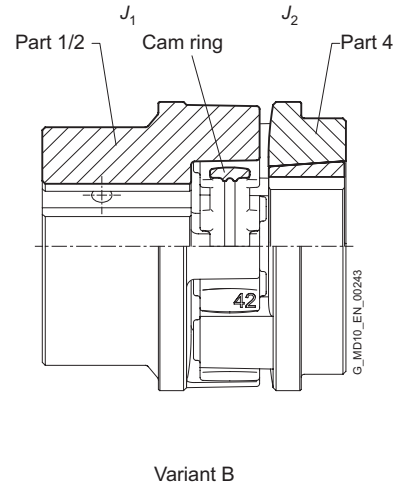
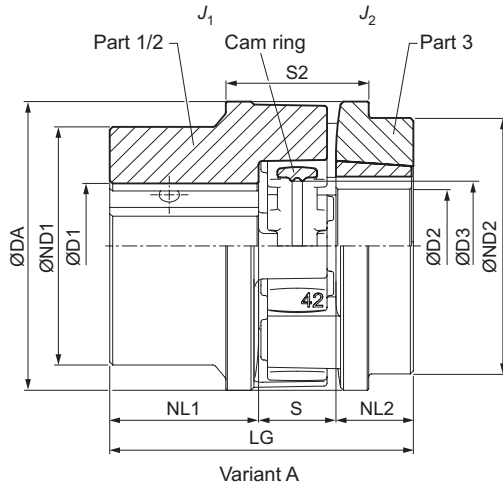

Size	Taper Clamping Bush Size	Rated torque		Speed $n_{Kmax}$ rpm	Dimensions in mm														Mass moment of inertia		Article no. <sup>1)</sup>		Weight $m$ kg
		$T_{KN}$	$T_{KN}$		D1 Keyway DIN 6885 min.   max.	D2 Keyway DIN 6885 min.   max.	DA	ND1	ND2	NL1	NL2	D3	S	S2	$\Delta S2$	LG	$J_1$ kgm <sup>2</sup>	$J_2$ kgm <sup>2</sup>	Type A	B			
		92 ShoreA Nm	95 ShoreA Nm																				
24	1008	45	65	14500	0	35	10	25	55	55	54	30	23	25	18	-	1.5	71	0.002	0.00016	2LC0160-1AE	2LC0160-1AF	0.7
28	1108	95	160	12500	0	40	10	28	67	58	58	35	23	28	20	41	1	78	0.0003	0.0002	2LC0160-2AE	2LC0160-2AF	0.8
38	1108	190	325	10000	0	48	10	28	82	68	58	45	23	36	24	45	1.5	92	0.0009	0.0005	2LC0160-3AE	2LC0160-3AF	1.4
42	1610	265	450	8500	0	55	14	42	97	80	86	50	26	43	26	48	1.5	102	0.002	0.0013	2LC0160-4AE	2LC0160-4AF	2.3
48	1615	330	550	7500	0	62	14	42	107	90	80	56	39	48	28	50	2	123	0.003	0.002	2LC0160-5AE	2LC0160-5AF	3.2
55	2012	460	700	6500	0	75	14	50	120	110	100	65	33	57	30	73	2	128	0.008	0.004	2LC0160-6AE	2LC0160-6AF	5.3
65	2012	670	1000	6000	0	82	14	50	135	115	100	75	33	64	35	78	2.5	143	0.013	0.006	2LC0160-7AE	2LC0160-7AF	6.9
	156																	0.013	0.008	7.4			
75	2517	1400	2000	5000	0	96	160	60	160	135	118	85	46	76	40	89.5	2.5	171	0.027	0.015	2LC0160-8AE	2LC0160-8AF	11.2
	177																	0.027	0.017	11.1			
90	3020	2500	3700	4000	0	120	25	75	205	170	142	100	52	95	45	85	3	197	0.065	0.036	2LC0161-0AE	2LC0161-0AF	17.2
	235																	0.065	0.06	20.7			

### Configurable variants <sup>1)</sup>

- Type: A, B
- ØD1: Without Taper clamping bush, With Taper clamping bush
- ØD2: Without Taper clamping bush, With Taper clamping bush
- Cam ring hardness: 92 ShoreA, 95 ShoreA

### Ordering example

- N-BIPEX BNT coupling, size 42, variant B
  - Part 1/2: Bore D1 42 H7 mm, with keyway to DIN 6885-1 and set screw
  - Part 4: With Taper clamping bushes, size 1610, bore D2 32 H7 mm, with keyway to DIN 6885-1
  - Cam ring hardness 92 ShoreA
- Article no.: 2LC0160-4AF99-0AA0-Z LOX+M0T

### Notes

- Mass moments of inertia apply to a coupling half with maximum bore diameter and without Taper clamping bush.
- Weights apply to a whole coupling in the version without taper clamping bush.
- $T_{Kmax}$  for the 95 ShoreA cam ring is limited to  $2 \times T_{KN}$  for types BWT and BNT contrary to the table on Page 9/7. When using the 64 ShoreD cam ring, the same torque values apply as for the 95 ShoreA cam ring.

<sup>1)</sup> To identify complete item numbers specifying the available finish boring options and – if necessary – further order options, please use our configurators on flender.com.  
<sup>2)</sup> Taper clamping bush version only possible in part 4.  
 ↗ For online configuration on flender.com, click on the item no.

# SPARE AND WEAR PARTS

## Cam rings of the N-BIPEX coupling

Size	Article no. N-BIPEX cam ring			Weight kg
	92 ShoreA	95 ShoreA	64 ShoreD	
19	2LC0160-0WA00-0AA0	2LC0160-0WA00-0AA0-Z K01	2LC0160-0WA00-0AA0-Z K04	0.006
24	2LC0160-1WA00-0AA0	2LC0160-1WA00-0AA0-Z K01	2LC0160-1WA00-0AA0-Z K04	0.02
28	2LC0160-2WA00-0AA0	2LC0160-2WA00-0AA0-Z K01	2LC0160-2WA00-0AA0-Z K04	0.03
38	2LC0160-3WA00-0AA0	2LC0160-3WA00-0AA0-Z K01	2LC0160-3WA00-0AA0-Z K04	0.04
42	2LC0160-4WA00-0AA0	2LC0160-4WA00-0AA0-Z K01	2LC0160-4WA00-0AA0-Z K04	0.07
48	2LC0160-5WA00-0AA0	2LC0160-5WA00-0AA0-Z K01	2LC0160-5WA00-0AA0-Z K04	0.09
55	2LC0160-6WA00-0AA0	2LC0160-6WA00-0AA0-Z K01	2LC0160-6WA00-0AA0-Z K04	0.1
65	2LC0160-7WA00-0AA0	2LC0160-7WA00-0AA0-Z K01	2LC0160-7WA00-0AA0-Z K04	0.2
75	2LC0160-8WA00-0AA0	2LC0160-8WA00-0AA0-Z K01	2LC0160-8WA00-0AA0-Z K04	0.4
90	2LC0161-0WA00-0AA0	2LC0161-0WA00-0AA0-Z K01	2LC0161-0WA00-0AA0-Z K04	0.6

### Note

- The cam rings of the N-BIPEX coupling are wear parts. The service life depends on the operating conditions.



# HIGHLY FLEXIBLE COUPLINGS ELPEX-B SERIES



<b>General</b>	<b>10/3</b>
Benefits	10/3
Application	10/3
Design and configurations	10/4
Technical specifications	10/6
<hr/>	
<b>Type EBWN</b>	<b>10/7</b>
<hr/>	
<b>Type EBWT</b>	<b>10/8</b>
<hr/>	
<b>Type EBWZ</b>	<b>10/10</b>
<hr/>	
<b>Spare and wear parts</b>	<b>10/12</b>
<hr/>	



ELPEX-B  
**FLENDER**





# GENERAL



ELPEX-B couplings are highly flexible and free of torsional backlash. Because of their low torsional stiffness and damping capacity, ELPEX-B couplings are especially suitable for coupling machines with a highly non uniform torque pattern. ELPEX-B couplings are also suitable for connecting machines with high shaft misalignment.

Standard ELPEX-B coupling types are designed as shaft-shaft connections. Application-related types can be implemented on request.

## Benefits

The ELPEX-B coupling is suitable for horizontal and vertical mounting positions or mounting positions at any required angle.

The elastic tire is slit at the circumference and can be changed without having to move the coupled machines.

The elastic tire is fitted without backlash and gives the coupling linear torsional stiffness, thus the torsional rigidity remains constant as the load on the coupling increases.

The ELPEX-B coupling is especially suitable for reversing operation or operation with changing directions of load. The coupling parts can be arranged as required on the shafts to be connected.

If the elastic tire is irreparably damaged or worn, the metal parts can rotate freely against one another because they are not in contact with one another.

## Application

The ELPEX-B coupling is available as a catalog standard in 15 sizes with a rated torque of between 24 Nm and 14500 Nm. The coupling can be fitted with elastic tires made of natural rubber for ambient temperatures of -50 °C to +50 °C and with elastic tires made of chloroprene rubber for -15 °C to +70 °C.

The chloroprene rubber tire is marked FRAS, "Fire-resistant and Antistatic".

# GENERAL

## Design and configurations

The ELPEX-B coupling's transmission characteristic is determined essentially by the elastic tire. The elastic tire is manufactured from a natural rubber or a chloroprene rubber mixture with a multiply fabric insert. The elastic tire is fastened to the hubs with bolts and two clamping rings.

In type EBWT, the shaft-hub connection is achieved with Taper clamping bushes, in type EBWN with finish-drilled hubs and parallel keys. The type EBWZ connects the machine shafts additionally via a detachable adapter.

## Metal part materials

- EN-GJL-250 grey cast iron or steel.

## Elastic tire material

Material	Hardness	Marking	Ambient temperature
Natural rubber	70 ShoreA	48	-50 ... +50 °C
Chloroprene rubber	70 ShoreA	068 FRAS	-15 ... +70 °C

10

## ELPEX-B coupling types

Type	Description
EBWN	Coupling as a shaft-shaft connection with drilled and grooved hubs
EBWT	Coupling as a shaft-shaft connection with Taper clamping bushes
EBWZ	Coupling as shaft-shaft connection with detachable adapter

Further application-specific coupling types are available; dimension sheets for and information on these are available on request.

The coupling types set up for shaft-hub connections with Taper clamping bushes are designated as follows:

- Variant A: Coupling with part 3 – part 3
- Variant B: Coupling with part 4 – part 4
- Variant AB: Coupling with part 3 – part 4

In the case of part 3, the Taper clamping bush is screwed in from the shaft end face side. The coupling half must be fitted before the machines to be connected are pushed together.

In the case of part 4, the Taper clamping bush is screwed in from the machine-housing side. If there is insufficient room, the Taper clamping bushes cannot be fitted from this side. Besides fitting space for the Taper clamping bush bolts, space for the fitting tool (offset screwdriver) must be taken into account.

In the case of coupling type EBWT, part 3 and part 4 can be combined as required. Furthermore, the variant with a Taper clamping bush can be combined with the finish-drilled hub.

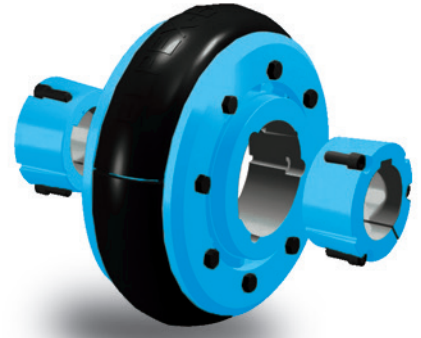

Unfitted coupling

Fitted coupling  
[shown without connecting shafts]

Fitted elastic tire

The elastic tire can simply be slipped over the hub parts. The elastic tire is held firmly in place by fitting the clamping ring. The connection transmits the torque by frictional engagement.

# GENERAL

## Technical specifications

Power ratings									
Size	Rated torque	Maximum torque	Overload torque	Fatigue torque	Maximum speed	Dynamic torsional stiffness	Permitted shaft misalignment at $n = 1500$ rpm <sup>1)</sup>		
	$T_{KN}$ Nm	$T_{Kmax}$ Nm	$T_{KOL}$ Nm	$T_{KW}$ Nm	$n_{Kmax}$ rpm	$C_{Tdyn}$ Nm/rad	Axial $\Delta K_a$ mm	Radial $\Delta K_r$ mm	Angle $\Delta K_w$ Degree
105	24	48	72	7	4500	285	1.3	1.1	4
135	66	132	200	20	4500	745	1.7	1.3	4
165	125	250	375	38	4000	1500	2	1.6	4
190	250	500	750	75	3600	2350	2.3	1.9	4
210	380	760	1140	114	3100	3600	2.6	2.1	4
235	500	1000	1500	150	3000	5200	3	2.4	4
255	680	1360	2040	204	2600	7200	3.3	2.6	4
280	880	1760	2640	264	2300	10000	3.7	2.9	4
315	1350	2700	4050	405	2050	17000	4	3.2	4
360	2350	4700	7050	705	1800	28000	4.6	3.7	4
400	3800	7600	11400	1140	1600	44500	5.3	4.2	4
470	6300	12600	18900	1890	1500	78500	6	4.8	4
510	9300	18600	27900	2790	1300	110000	6.6	5.3	4
560	11500	23000	34500	3450	1100	160000	7.3	5.8	4
630	14500	29000	43500	4350	1000	200000	8.2	6.6	4

### Torsional stiffness and damping

The damping coefficient is  $\Psi = 0.9$

The technical data for the elastic tires made of natural rubber and chloroprene rubber are virtually identical.

Torsional stiffness depends on the ambient temperature and the frequency and amplitude of the torsional vibration excitation. More precise torsional stiffness and damping parameters on request.

With flexible couplings the manufacturing process of the rubber elements and their aging primarily influence the stiffness value  $C_{Tdyn}$ . For this reason calculation must be made with a tolerance for the dynamic stiffness of  $\pm 20\%$ . The specified damping coefficient  $\Psi$  is a minimum value with the result that the damping performance of the coupling corresponds at least to the specified value.

### Permitted shaft misalignment

The permitted shaft misalignment depends on the operating speed. As the speed increases, lower shaft misalignment values are permitted. The correction factors for different speeds are specified in the following table. The maximum speed for the respective coupling size must be noted.

$$\Delta K_{perm} = \Delta K_{1500} \cdot FKV$$

	Speed in rpm			
	500	1000	1500	3000
Correction factor FKV	1.2	1.1	1.0	0.7

The restorative force (including in the axial direction) depends on speed, system torque and shaft misalignment. Restorative forces on request.

<sup>1)</sup> The maximum speed for the respective type must be noted. For additional information on the allowable shaft misalignment, please refer to the operating instructions.

# TYPE EBWN

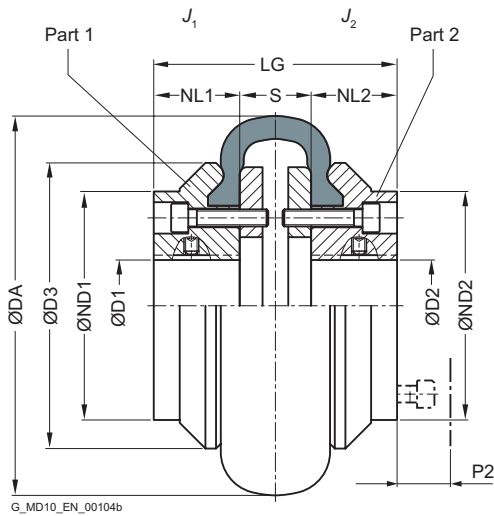

Sizes 105 ... 165

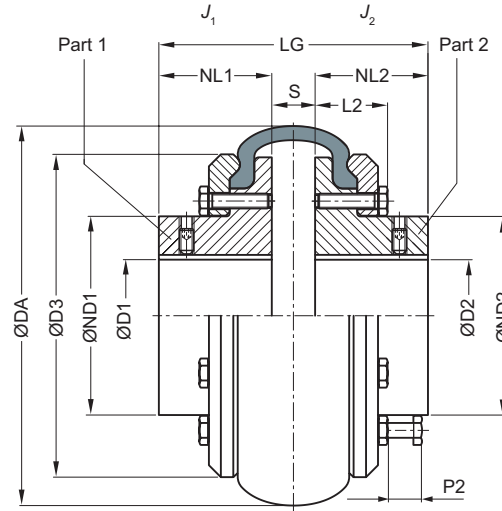

Sizes 190 ... 630

Size	Rated torque $T_{KN}$ Nm	Dimensions in mm										Mass moment of inertia $J_1/J_2$ kgm <sup>2</sup>	Article no. <sup>1)</sup>	Weight $m$ kg
		D1, D2 Keyway DIN 6885-1 min.   max.		DA	ND1/ ND2	NL1/ NL2	D3	L2	S	P2	LG			
105	24	-	30	104	70	30	82	-	22	35	82	0.0011	2LC0210-0AA	2.2
135	66	-	38	134	80	40	100	-	25	35	105	0.0025	2LC0210-1AA	3.6
165	125	-	45	165	70	50	125	-	33	35	133	0.0056	2LC0210-2AA	5.4
190	250	-	50	187	80	55	145	36	23	35	133	0.0095	2LC0210-3AA	6.9
210	380	-	60	211	98	65	168	40	25	35	155	0.02	2LC0210-4AA	11
235	500	-	70	235	111	70	188	45	27	35	167	0.023	2LC0210-5AA	14.8
255	680	-	80	254	130	75	216	44	27	35	177	0.06	2LC0210-6AA	20
280	880	-	90	280	145	80	233	45	25	35	185	0.083	2LC0210-7AA	24.5
315	1350	-	95	314	155	90	264	50	29	35	209	0.129	2LC0210-8AA	35
360	2350	-	125	359	200	100	311	50	32	35	232	0.32	2LC0211-0AA	54
400	3800	-	135	402	216	125	345	59	30	35	280	0.55	2LC0211-1AA	78
470	6300	-	160	470	260	140	398	67	46	35	326	1.12	2LC0211-2AA	120
510	9300	-	140	508	250	150	429	73	48	35	348	1.6	2LC0211-3AA	146
		140	290		1.7							154		
560	11500	-	140	562	250	165	474	82	55	35	385	2.5	2LC0211-4AA	200
		140	300		2.7							206		
630	14500	80	140	629	250	195	532	82	59	35	449	4.1	2LC0211-5AA	258
		140	180		300							4.4		265

### Configurable variants<sup>1)</sup>

- ØD1 Without finished bore  
With finished bore
- ØD2 Without finished bore  
With finished bore

### Notes

- Weight and mass moments of inertia apply to maximum bore diameters.
- The article no. applies to elastic tires made of natural rubber.
- P2 = fitting space for dismounting the elastic tire

### Ordering example

- ELPEX-B EBWN coupling, size 210
- Part 1: Bore 40H7mm, keyway to DIN 6885-1 and set screw
- Part 2: Bore 45H7 mm, keyway to DIN 6885-1 and set screw

Article no.: 2LC0210-4AA99-0AA0-Z L0W+M1A

<sup>1)</sup> To identify complete item numbers specifying the available finish boring options and – if necessary – further order options, please use our configurators on [flender.com](http://flender.com).

➤ For online configuration on [flender.com](http://flender.com), click on the item no.

# TYPE EBWT

Sizes 105 ... 165

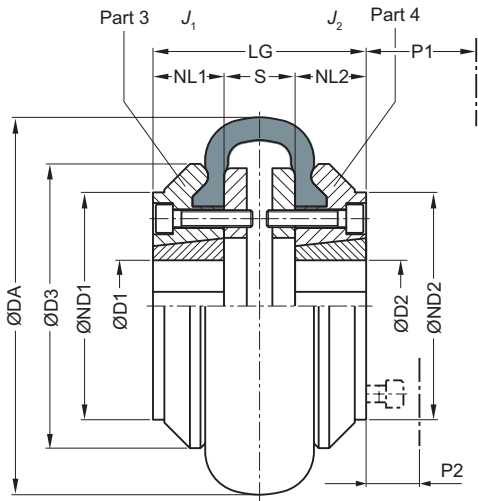

Variant AB

Sizes 190 ... 560

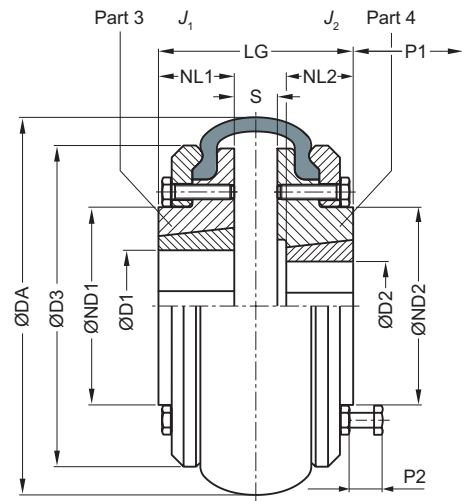

Variant AB

10

Sizes 105 ... 165

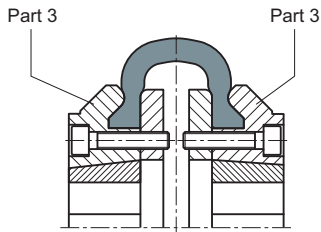

Variant A

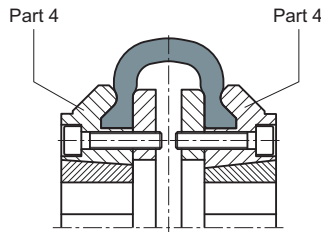

Variant B

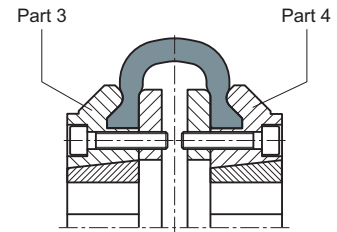

Variant AB

Sizes 190 ... 560

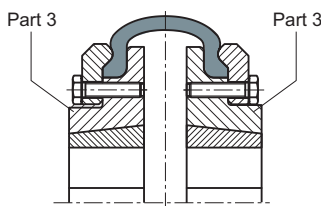

Variant A

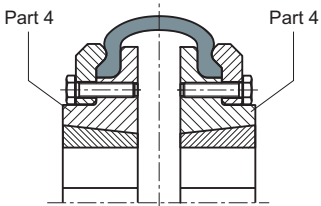

Variant B

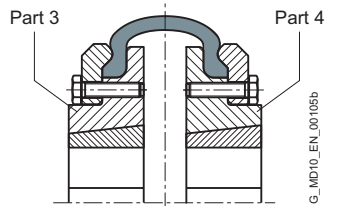

Variant AB

G\_MD10\_EN\_00105b

Part 3: Screw connection for Taper clamping bush from the shaft end face side  
 Part 4: Screw connection for Taper clamping bush from the machine-housing side

Size	Rated torque $T_{KN}$ Nm	Part no.	Taper Clamping Bush Size	Dimensions in mm											Mass moment of inertia $J_1/J_2$ kgm <sup>2</sup>	Article no. <sup>1)</sup>			Weight $m$ kg
				D1, D2 Keyway DIN 6885-1		DA	ND1/ND2	NL1/NL2	D3	S	P1	P2	LG	Type					
				min.	max.									A		B	AB		
105	24	$\frac{3}{4}$	1008	10	25	104	-	22	82	22	29	35	66	0.0009	2LC0210-0AB	2LC0210-0AC	2LC0210-0AD	1.8	
135	66	$\frac{3}{4}$	1210	11	32	134	80	25	100	25	38	35	75	0.0019	2LC0210-1AB	2LC0210-1AC	2LC0210-1AD	2.4	
165	125	$\frac{3}{4}$	1610	14	42	165	103	25	125	33	38	35	83	0.0049	2LC0210-2AB	2LC0210-2AC	2LC0210-2AD	4	
190	250	$\frac{3}{4}$	2012	14	50	187	80	$\frac{32}{25}$	145	23	$\frac{42}{38}$	35	87	0.0085	2LC0210-3AB	2LC0210-3AC	2LC0210-3AD	5.4	
210	380	$\frac{3}{4}$	2517	16	60	211	98	$\frac{45}{32}$	168	25	$\frac{48}{42}$	35	$\frac{115}{89}$	0.017	2LC0210-4AB	2LC0210-4AC	2LC0210-4AD	8	
235	500	$\frac{3}{4}$	2517	16	60	235	108	46	188	27	48	35	119	0.019	2LC0210-5AB	2LC0210-5AC	2LC0210-5AD	12	
255	680	$\frac{3}{4}$	3020	25	75	254	$\frac{120}{113}$	$\frac{51}{45}$	216	27	$\frac{55}{48}$	35	$\frac{129}{117}$	0.05	2LC0210-6AB	2LC0210-6AC	2LC0210-6AD	14	
280	880	$\frac{3}{4}$	3020	25	75	280	134	52	233	25	55	35	129	0.075	2LC0210-7AB	2LC0210-7AC	2LC0210-7AD	22	
315	1350	$\frac{3}{4}$	3525	35	100	314	140	$\frac{66}{51}$	264	29	$\frac{67}{55}$	35	$\frac{161}{131}$	0.11	2LC0210-8AB	2LC0210-8AC	2LC0210-8AD	23	
360	2350	$\frac{3}{4}$	3525	35	100	359	178	65	311	32	67	35	162	0.26	2LC0211-0AB	2LC0211-0AC	2LC0211-0AD	38	
400	3800	$\frac{3}{4}$	4030	40	115	402	200	77	345	30	80	35	184	0.44	2LC0211-1AB	2LC0211-1AC	2LC0211-1AD	54	
470	6300	$\frac{3}{4}$	4535	55	125	470	210	89	398	46	89	35	224	0.8	2LC0211-2AB	2LC0211-2AC	2LC0211-2AD	72	
510	9300	$\frac{3}{4}$	4535	55	125	508	208	89	429	48	89	35	226	1.5	2LC0211-3AB	2LC0211-3AC	2LC0211-3AD	120	
560	11500	$\frac{3}{4}$	5040	70	125	562	224	102	474	55	92	35	259	2	2LC0211-4AB	2LC0211-4AC	2LC0211-4AD	120	

**Configurable variants <sup>1)</sup>**

- ØD1 Without finished bore  
With finished bore
- ØD2 Without finished bore  
With finished bore

**Notes**

- Weights and mass moments of inertia apply to couplings with Taper clamping bushes with maximum bore diameter.
- The article no. applies to elastic tires made of natural rubber.
- P1 = fitting space for offset screwdriver and ejector bolt for dismantling the Taper clamping bush
- P2 = fitting space for dismantling the elastic tire.

**Ordering example**

- ELPEX-B EBWT coupling, size 210, variant AB, including Taper clamping bushes
- Part 3: with Taper clamping bush, bore 60 mm
- Part 4: with Taper clamping bush, bore 40 mm

Article no.: 2LC0210-4AD99-0AA0-Z L1E+M0W

<sup>1)</sup> To identify complete item numbers specifying the available finish boring options and – if necessary – further order options, please use our configurators on [flender.com](http://flender.com).

➤ For online configuration on [flender.com](http://flender.com), click on the item no.

# TYPE EBWZ

Sizes 190 ... 470

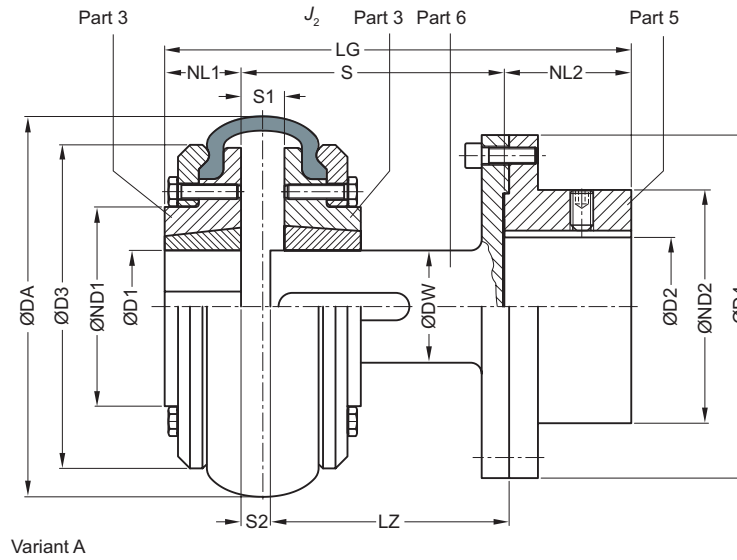

10

Sizes 105 ... 165

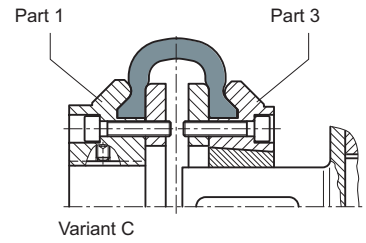
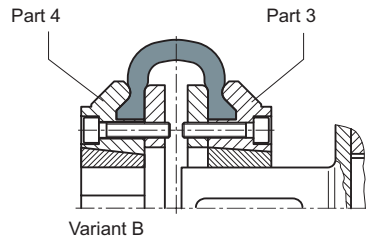
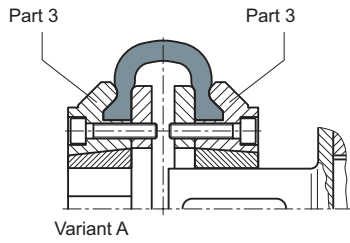

Sizes 190 ... 470

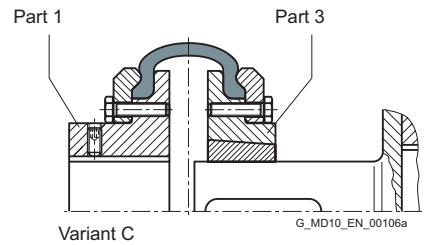
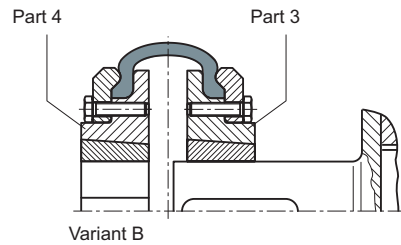
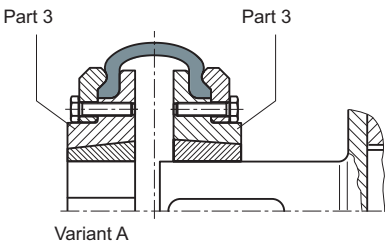

G\_MD10\_EN\_00106a

Part 3: Screw connection for Taper clamping bush from the shaft end face side  
 Part 4: Screw connection for Taper clamping bush from the machine-housing side



Size	Rated torque $T_{KN}$ Nm	Dimensions in mm												Mass moment of inertia $J_2$ kgm <sup>2</sup>	Article no. <sup>1)</sup>			Weight $m$ kg	
		D1, D2 Keyway DIN 6885-1		DA	ND2	D4	DW	NL2	LZ	S		S1	S2		Type	A	B		C
		min.	max.							min.	max.								
105	24	-	42	104	70	95	25	45	96 133	100 140	116 156	22	6	0.0027	2LC0210-0AG	2LC0210-0AH	2LC0210-0AJ	3.3	
135	66	-	55	134	90	125	32	50	93 133	100 140	116 156	25	9	0.0085	2LC0210-1AG	2LC0210-1AH	2LC0210-1AJ	5.4	
165	125	-	55	165	90	125	32	50	93 133	100 140	124 164	33	9	0.012	2LC0210-2AG	2LC0210-2AH	2LC0210-2AJ	6.2	
190	250	-	75	187	125	180	48	80	93.5 133.5	100 140	114 154	23	9	0.046	2LC0210-3AG	2LC0210-3AH	2LC0210-3AJ	16	
210	380	-	75	211	125	180	48	80	133.5 173.5	140 180	156 194	25	9	0.053	2LC0210-4AG	2LC0210-4AH	2LC0210-4AJ	17	
235	500	-	75	235	125	180	48	80	133.5 173.5	140 180	158 198	27	9	0.056	2LC0210-5AG	2LC0210-5AH	2LC0210-5AJ	25	
255	680	-	90	254	150	225	60	100	133.5 173.5	140 180	158 198	27	9	0.15	2LC0210-6AG	2LC0210-6AH	2LC0210-6AJ	29	
280	880	-	90	280	150	225	60	100	133.5 173.5	140 180	156 196	25	9	0.17	2LC0210-7AG	2LC0210-7AH	2LC0210-7AJ	33	
315	1350	46	100	314	165	250	80	110	134.5 174.5	140 180	160 200	29	9	0.28	2LC0210-8AG	2LC0210-8AH	2LC0210-8AJ	40	
360	2350	46	100	359	165	250	80	110	134.5 174.5	140 180	163 203	32	9	0.43	2LC0211-0AG	2LC0211-0AH	2LC0211-0AJ	48	
400	3800	51	110	402	180	280	90	120	223.5	230	250	30	10	0.88	2LC0211-1AG	2LC0211-1AH	2LC0211-1AJ	73	
470	6300	51	120	470	200	315	100	140	207.5	214	250	46	10	0.97	2LC0211-2AG	2LC0211-2AH	2LC0211-2AJ	104	

**Configurable variants<sup>1)</sup>**

- ØD1 Without finished bore  
With finished bore

---

- ØD2 Without finished bore  
With finished bore

---

- S min. 100 mm  
140 mm  
180 mm

**Notes**

- Dimensions D1, ND1, NL1, J1 and fitting space for dismantling elastic tire and Taper clamping bush, see types EBWN or EBWT, **Page 10/7** or **Page 10/8**
- The article no. applies to elastic tires made of natural rubber.
- Mass moment of inertia  $J_2$  and weight  $m$  as total of part 3, part 5 and part 6 with maximum bore diameter.

**Ordering example**

- ELPEX-B EBWZ coupling, size 360
  - variant C, for fitting length S min. = 190 mm
  - Part 1: Bore 65H7 mm, keyway to DIN 6885-1 and set screw
  - Part 5: Bore 70H7 mm, keyway to DIN 6885-1 and set screw
- Article no.: **2LC0211-0AJ99-0AC0-Z L1F+M1G**

<sup>1)</sup> To identify complete item numbers specifying the available finish boring options and – if necessary – further order options, please use our configurators on [flender.com](http://flender.com).

↗ For online configuration on [flender.com](http://flender.com), click on the item no.

# SPARE AND WEAR PARTS

## Elastic tire

Size	Article No.		Chloroprene rubber	
	Natural rubber Identification 048	Weight kg	Identification 068 FRAS	Weight kg
105	2LC0210-0WA00-0AA0	0.1	2LC0210-0WA00-0AA0-Z K01	0.1
135	2LC0210-1WA00-0AA0	0.2	2LC0210-1WA00-0AA0-Z K01	0.2
165	2LC0210-2WA00-0AA0	0.4	2LC0210-2WA00-0AA0-Z K01	0.4
190	2LC0210-3WA00-0AA0	0.5	2LC0210-3WA00-0AA0-Z K01	0.5
210	2LC0210-4WA00-0AA0	0.8	2LC0210-4WA00-0AA0-Z K01	0.8
235	2LC0210-5WA00-0AA0	1	2LC0210-5WA00-0AA0-Z K01	1
255	2LC0210-6WA00-0AA0	1.2	2LC0210-6WA00-0AA0-Z K01	1.2
280	2LC0210-7WA00-0AA0	1.4	2LC0210-7WA00-0AA0-Z K01	1.4
315	2LC0210-8WA00-0AA0	2.6	2LC0210-8WA00-0AA0-Z K01	2.6
360	2LC0211-0WA00-0AA0	2.9	2LC0211-0WA00-0AA0-Z K01	2.9
400	2LC0211-1WA00-0AA0	3.1	2LC0211-1WA00-0AA0-Z K01	3.1
470	2LC0211-2WA00-0AA0	5.3	2LC0211-2WA00-0AA0-Z K01	5.3
510	2LC0211-3WA00-0AA0	7.8	2LC0211-3WA00-0AA0-Z K01	7.8
560	2LC0211-4WA00-0AA0	10.8	2LC0211-4WA00-0AA0-Z K01	10.8
630	2LC0211-5WA00-0AA0	12.4	2LC0211-5WA00-0AA0-Z K01	12.4

10

### Note

- The elastic tires are wear parts.  
The service life depends on the operating conditions.





# HIGHLY FLEXIBLE COUPLINGS – ELPEX-S SERIES



<b>General</b>	<b>11/3</b>
Benefits	11/3
Application	11/3
Design and configurations	11/4
Function	11/6
Configuration	11/6
Technical specifications	11/8
-----	
<b>Type ESN</b>	<b>11/14</b>
-----	
<b>Type ESNR</b>	<b>11/16</b>
-----	
<b>Type ESD</b>	<b>11/18</b>
-----	
<b>Type ESDR</b>	<b>11/19</b>
-----	
<b>Type ESNW</b>	<b>11/20</b>
-----	
<b>Type ESDW</b>	<b>11/21</b>
-----	
<b>Type EST</b>	<b>11/22</b>
-----	
<b>Spare and wear parts</b>	<b>11/23</b>
-----	



ELPEX-S  
**FLENDER**



# GENERAL



**Coupling suitable for use in potentially explosive atmospheres.**

**Complies with the current ATEX Directive for:**

CE  II 2G Ex h IIC T4 ... T3 Gb X

 II 2D Ex h IIIC T120 °C ... 160 °C Db X

 I M2 Ex h Mb X

(Type EST is not available in Ex version.)

ELPEX-S couplings are highly torsionally flexible and because of their low torsional stiffness and damping capacity are especially suitable for coupling machines with a highly non uniform torque pattern.

Standard ELPEX-S coupling types are designed as flange-shaft-connections or shaft-shaft connections.

Application-related types can be implemented on request.

## Benefits

The ELPEX-S coupling is suitable for horizontal and vertical mounting positions or mounting at any required angle. The coupling parts can be arranged as required on the shafts to be connected.

ELPEX-S couplings are especially suitable for reversing operation or operation with changing directions of load.

The rubber disk elements are fitted virtually without backlash and give the coupling linear torsional stiffness, i.e. the torsion stiffness remains constant even when the load on the coupling increases.

There are 4 different rubber element versions with different grades of torsional stiffness available for each size from stock.

## Application

The ELPEX-S coupling is available as a catalog standard in 12 sizes with rated torques of between 330 Nm and 63000 Nm.

The coupling is suitable for ambient temperatures of between -40 °C and +120 °C.

The ELPEX-S coupling is frequently used for diesel motor drives or reciprocating compressor drives.

On certain types the flexible rings can be changed without having to move the coupled machines.

If substantial overload occurs, the rubber disk element of the coupling is irreparably damaged, the coupling throws the load and thus limits the overload for particular operating conditions. The coupling can be inserted and fitted blind e.g. in a bell housing.

There are outer flanges with different connection dimensions available for each coupling size.

Because the different rubber versions enable the torsional stiffness to be adjusted to meet requirements, the coupling is also suitable for drives which require a specific and preferably precalculated torsional vibration behavior setting.

# GENERAL

## Design and configurations

The rubber disk element is vulcanized onto a flange on the inside diameter. The flange can mount e.g. a Taper clamping bush or a hub. On its outer diameter the rubber disk element has driving teeth, which are inserted into the outer flange. The torque is transmitted positively between the rubber disk element and the outer flange.

In the type for shaft-shaft connection the outer flange is screwed to a flange hub mounted on a machine shaft.

### Materials

	Type EST	Types ESN. and ESD.
Rubber disk element	EN-GJL-250 grey cast iron/ elastomer	EN-GJL-400 spheroidal graphite cast iron/elastomer
Hubs, part 1, part 2	Steel	Steel
Outer flange	Cast aluminum Zn10Si8Mg Sizes 680 and 770 of spheroidal graphite cast iron EN-GJS-500	Cast aluminum Zn10Si8Mg Sizes 680 and 770 of spheroidal graphite cast iron EN-GJS-500

### Elastomer materials of the rubber disk element

Material/ description	Hardness ShoreA	Marking	Ambient temperature
Natural-synthetic rubber mixture	50 ° ... 55 °	WN	-40 °C ... +80 °C
	60 ° ... 65 °	NN	-40 °C ... +80 °C
	70 ° ... 75 °	SN	-40 °C ... +80 °C
Silicone rubber	55 ° ... 65 °	NX	-40 °C ... +120 °C

11

### ELPEX-S coupling types

Type	Description
<b>ESN</b>	Coupling with hub, long or short version
<b>ESD</b>	Coupling with hub, with two rubber disk elements
<b>ESNR</b>	Coupling with hub, rubber disk element radially dismountable
<b>ESDR</b>	Coupling with hub with two rubber disk elements; rubber disk elements radially dismountable
<b>ESNW</b>	Coupling designed as a shaft-shaft connection with a rubber disk element; rubber disk element radially dismountable
<b>ESDW</b>	Coupling designed as a shaft-shaft connection with two rubber disk elements; rubber disk element radially dismountable
<b>EST</b>	Coupling suitable for mounting a Taper clamping bush

Further application-related coupling types are available. Dimension sheets for and information on these are available on request.

The following versions have already been implemented a number of times:

- ELPEX-S coupling with brake drum, brake disk or flywheel mass
- ELPEX-S coupling with axial backlash limiter
- ELPEX-S coupling with adapter
- ELPEX-S coupling with bearing for mounting a cardan shaft
- ELPEX-S coupling for engaging/disengaging during standstill
- ELPEX-S coupling as part of a coupling combination
- ELPEX-S coupling with fail-safe device



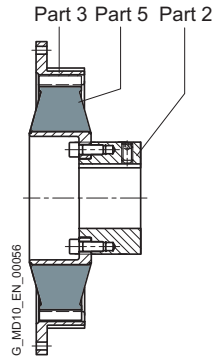

Type ESN – long version

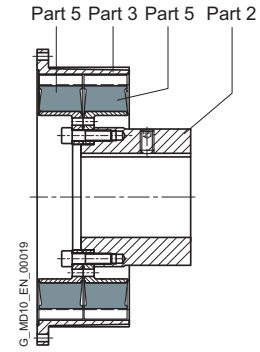

Type ESD

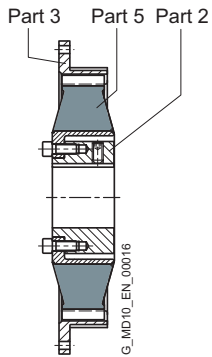

Type ESN – short version

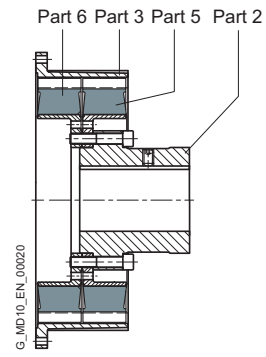

Type ESDR

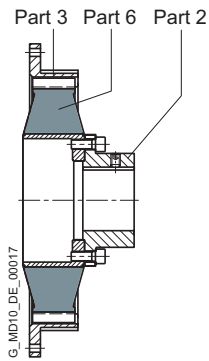

Type ESNR

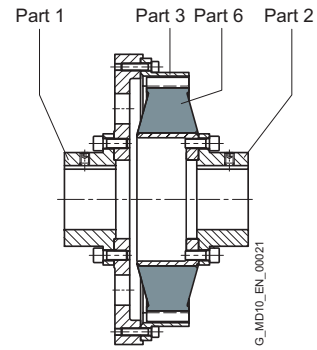

Type ESNW

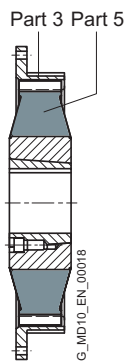

Type EST

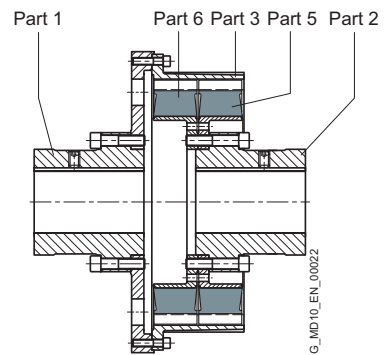

Type ESDW

# GENERAL

## Fail-safe device of ELPEX-S coupling

The ELPEX-S coupling can also be designed with a fail-safe device. If the rubber disk element fails, the coupling can continue operating in emergency mode for a short time. This option is frequently required e.g. in the case of marine drives.

If the rubber disk element fails, cams transmit the torque from the inner and outer parts of the fail-safe device.

In normal operation the torsion angle of the rubber disk element is smaller than the gap between the cams, so there is no metal-metal contact.

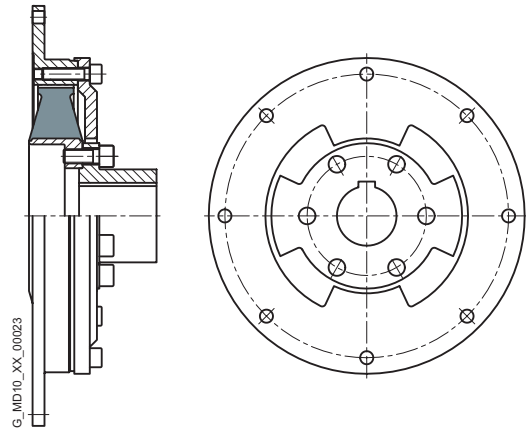

## Function

The ELPEX-S coupling's transmission characteristic is determined essentially by the rubber disk element. The torque is transmitted positively between the rubber disk element and the outer flange.

The outer flange can be bolted to e.g. a diesel motor or compressor flywheel.

11

## Configuration

### Coupling selection

The ELPEX-S coupling is especially suitable for rough operating environments. An application factor lower than that in the **chapter introduction** is therefore sufficient for all applications.

In the case of machines which excite torsional vibration, Flender urgently recommends carrying out a torsional vibration calculation or measuring the coupling load occurring in the drive.

### Coupling load in continuous operation

Application factor FB	Torque characteristic of the driven machine		
	uniform with moderate shock loads	non uniform	very rough
Electric motors, hydraulic motors, gas and water turbines	1.0	1.3	1.4
Internal-combustion engines	1.3	1.4	1.6

### Examples of torque characteristic in driven machines:

- uniform with moderate shock loads: Generators, fans, blowers
- non uniform: Reciprocating compressors, mixers, conveyor systems
- very rough: crushers, excavators, presses, mills

Temperature factor FT		Temperature $T_a$ on the coupling									
Coupling	Rubber version	Elastomer material	-40 up to -30 °C	-30 up to +50 °C	up to 60 °C	up to 70 °C	up to 80 °C	up to 90 °C	up to 100 °C	up to 110 °C	up to 120 °C
ELPEX-S	SN, NN, WN	NR	1.1	1.0	1.25	1.40	1.60	-	-	-	-
	NX	VMQ	1.1	1.0	1.0	1.0	1.0	1.1	1.25	1.4	1.6

NR = Natural-synthetic rubber mixture  
 VMQ = Silicone rubber

$$\text{Coupling size } T_{KN} \geq T_N \cdot FB \cdot FT$$

### Coupling load under maximum and overload conditions

The maximum torque is the highest load acting on the coupling in normal operation.

Maximum torques at a frequency of up to 25 times an hour are permitted and must be lower than the maximum coupling torque. Examples of maximum torque conditions are: Starting operations, stopping operations or usual operating conditions with maximum load.

$$T_{K_{\max}} \geq T_{\max} \cdot FT$$

Overload torques are maximum loads which occur only in combination with special, infrequent operating conditions. Examples of overload torque conditions are: Motor short circuit, emergency stop or blocking because of component breakage. Overload torques at a frequency of once a month are permitted and must be lower than the maximum overload torque of the coupling. The overload condition may last only a short while, i.e. fractions of a second.

$$T_{K_{OL}} \geq T_{OL} \cdot FT$$

### Coupling load due to dynamic torque load

Applying the frequency factor FF, the dynamic torque load must be lower than the coupling fatigue torque.

Dynamic torque load





$$T_{KW} \geq T_W \cdot FF \cdot FF$$

Frequency of the dynamic torque load

$$f_{err} \leq 10 \text{ Hz frequency factor } FF = 1.0$$

Frequency of the dynamic torque load

$$f_{err} > 10 \text{ Hz frequency factor } FF = \sqrt{(f_{err}/10 \text{ Hz})}$$

-  Operation in potentially explosive environments is subject to the following restriction:  
Operation with low fatigue load
-  The fatigue torque TKW must be reduced by 70 %. In these particular operating conditions the coupling satisfies the requirements of temperature class T4 D120 °C.  
Operation with medium fatigue load
-  The fatigue torque TKW must be reduced by 50 %. In these particular operating conditions the coupling satisfies the requirements of temperature class T3 D160 °C.
-  Type EST is not permitted for application in potentially explosive environments.

### Checking the maximum speed

The following must apply to all load situations:  $n_{K_{\max}} \geq n_{\max}$   
The maximum speed of a size depends only on the size of the outer flange (part 3).

### Checking permitted shaft misalignment and restorative forces

For all load situations, the actual shaft misalignment must be less than the permitted shaft misalignment.

### Checking bore diameter, mounting geometry and coupling design

The check must be made on the basis of the dimension tables.

On request, couplings with adapted geometry can be provided.

### Checking shaft-hub connection

For any information on this, please refer to [Page E/20](#).

### Checking temperature and chemically aggressive environment

The permitted coupling temperature is specified in the Temperature Factor FT table. In the case of chemically aggressive environments, please consult the manufacturer.

# GENERAL

## Technical specifications

Performance data for rubber disk elements made of a mix of natural and synthetic rubber

Type	Size	Rubber version	Rated torque	Maximum torque	Overload torque	Fatigue torque	dynamic torsional stiffness	Motor flange SAE J620d Size	Maximum speed $n_{max}$ rpm
			$T_{KN}$ Nm	$T_{Kmax}$ Nm	$T_{KOL}$ Nm	$T_{KW}$ Nm	$C_{Tdyn}$ Nm/rad		
ESN . EST	220	WN	330	660	750	165	1600	6.5	4200
		NN	360	720	900	180	2500	7.5	4200
		SN	400	800	1000	200	4200	8 10	4200 3600
ESN . EST	265	WN	500	1000	1250	250	2400	8	4200
		NN	600	1200	1800	300	3600	10	3600
		SN	700	1400	2100	350	6100	11.5	3500
ESN . EST	290	WN	800	1600	2000	400	3600	10	3600
		NN	900	1800	2700	450	5000	11.5	3500
		SN	1000	2000	3000	500	7500		
ESN . EST	320	WN	1200	2400	3000	600	8000	11.5	3500
		NN	1350	2700	3600	650	10000	14	3000
		SN	1550	3100	4200	750	13500		
ESN . EST	360	WN	1800	3600	4500	900	8500	11.5	3200
		NN	2000	4000	5400	1000	13000	14	3000
		SN	2500	5000	7500	1250	22000		
ESN . EST	420	WN	3100	6200	7700	1500	16000	14	3000
		NN	3450	6900	10000	1700	30000	16	2600
		SN	4200	8400	12600	2100	45000	18	2300
ESN . EST	465	WN	4600	9200	10000	2300	35000	14	3000
		NN	5200	10400	15600	2600	56000	16	2600
		SN	6300	12600	18900	3100	100000	18	2300
ESN .	520	WN	6200	12400	14000	3100	38000	18	2300
		NN	7000	14000	21000	3500	75000	21	2000
		SN	7800	15600	23400	3900	110000		
ESD .	520	WN	12400	24800	28000	6200	76000	18	2300
		NN	14000	28000	42000	7000	150000	21	2000
		SN	15600	31200	46800	7800	220000		
ESN .	560	WN	8000	16000	18000	4200	55000	18	2300
		NN	9000	18000	27000	4800	100000	21	2000
		SN	10000	20000	30000	5500	190000		
ESD .	560	WN	16000	32000	36000	8400	110000	18	2300
		NN	18000	36000	54000	9600	200000	21	2000
		SN	20000	40000	60000	11000	380000		

Performance data for rubber disk elements made of a mix of natural and synthetic rubber									
Type	Size	Rubber version	Rated torque	Maximum torque	Overload torque	Fatigue torque	dynamic torsional stiffness	Motor flange SAE J620d Size	Maximum speed max rpm
			$T_{KN}$ Nm	$T_{Kmax}$ Nm	$T_{KOL}$ Nm	$T_{KW}$ Nm	$C_{Tdyn}$ Nm/rad		
ESN .	580	WN	11000	22000	28000	5500	75000	18	2300
		NN	12500	25000	37000	6250	120000		
		SN	14000	28000	42000	7000	210000		
ESD .	580	WN	22000	44000	56000	11000	150000	21	2000
		NN	25000	50000	74000	12500	240000		
		SN	28000	56000	84000	14000	420000		
ESN .	680	WN	16000	32000	40000	8000	150000	21	2000
		NN	18000	36000	54000	9000	250000		
		SN	20000	40000	60000	10000	450000		
ESD .	680	WN	32000	64000	80000	16000	300000	21	2000
		NN	36000	72000	108000	18000	500000		
		SN	40000	80000	120000	20000	900000		
ESN .	770	WN	25000	50000	75000	12500	250000	similar to DIN 6288	1500
		NN	28000	56000	84000	14000	400000		
		SN	31500	63000	94000	15000	700000		
ESD .	770	WN	50000	100000	150000	25000	500000	similar to DIN 6288	1300
		NN	56000	112000	168000	28000	800000		
		SN	63000	126000	189000	30000	1400000		

**Torsional stiffness and damping**

Torsional stiffness depends on the ambient temperature and the frequency and amplitude of the torsional vibration excitation. More precise torsional stiffness and damping parameters on request.

With flexible couplings the manufacturing process of the rubber elements and their aging primarily influence the stiffness value  $C_{Tdyn}$ .

For this reason calculation must be made with a tolerance for the dynamic stiffness of  $\pm 20\%$ . The specified damping coefficient  $\Psi$  is a minimum value with the result that the damping performance of the coupling corresponds at least to the specified value.

# GENERAL

## Technical specifications

Power ratings of the rubber disk elements made of silicone rubber											
Type	Size	Rubber version	Rated torque		Maximum torque		Overload torque		Fatigue torque		Dynamic torsional stiffness for 100 % load $C_{Tdyn}$ kNm/rad
			$T_{KN}$ Nm		$T_{Kmax}$ Nm		$T_{KOL}$ Nm		$T_{KW}(10\text{ Hz})$ Nm		
ESN .	220	NX	200		300		400		87		1.3
ESN .	265	NX	300		450		600		133		2.4
ESN .	290	NX	500		750		1000		213		4.2
ESN .	320	NX	770		1150		1530		320		9.2
ESN .	360	NX	1200		1800		2400		480		10
ESN .	420	NX	2000		3000		4000		800		23
ESN .	465	NX	3000		4500		6000		1200		60
ESN .	520	NX	4100		6100		8200		1600		65
ESD .	520	NX	8200		12300		16400		3200		130
ESN .	560	NX	5000		7500		10000		2200		100
ESD .	560	NX	10000		15000		20000		4400		200
ESN .	580	NX	6500		9750		13000		2667		160
ESD .	580	NX	13000		19500		26000		5867		310
ESN .	680	NX	10000		15000		20000		4000		280
ESD .	680	NX	20000		30000		40000		8000		550
ESN .	770	NX	15000		22500		30000		6000		620
ESD .	770	NX	30000		45000		60000		12000		1230

11

### Torsional stiffness

The dynamic torsional stiffness of the silicone rubber elements is load-dependent and increases in proportion to the load. The values specified in the selection table represent 100 % loading. The following table shows the correction factors for different rated loads.

Torsional stiffness also depends on the ambient temperature and the frequency and amplitude of the torsional vibration excitation. More precise torsional stiffness and damping parameters on request.

$$C_{Tdyn} = C_{Tdyn\ 100\%} \cdot FK_C$$

Correction factor FK <sub>C</sub>	Load $T_N / T_{KN}$						
	20%	50%	60%	70%	80%	100%	150%
	0.59	0.75	0.79	0.83	0.88	1	1.5

**Damping coefficient**

Damping coefficient of the rubber versions		
Rubber version	Hardness ShoreA	Damping coefficient $\Psi$
WN	55 ° ± 5 °	0.80
NN	65 ° ± 5 °	1.15
SN	75 ° ± 5 °	1.25
NX	60 ° ± 5 °	1.15

With flexible couplings the manufacturing process of the rubber elements and their aging primarily influence the stiffness value  $C_{Tdyn}$ . For this reason calculation must be made with a tolerance for the dynamic stiffness of ± 20 %. The specified damping coefficient  $\Psi$  is a minimum value with the result that the damping performance of the coupling corresponds at least to the specified value.

**Permitted shaft misalignment**

The permitted shaft misalignment depends on the operating speed. As the speed increases, lower shaft misalignment values are permitted.

For fitting, the maximum gap dimension of  $S_{max.} = S + \Delta S$  and the minimum gap dimension of  $S_{min.} = S - \Delta S$  are permitted.

Size	Assembly Shaft distance $\Delta S$ mm	Permitted shaft misalignment at $n = 1500$ rpm		
		Axial $\Delta K_a$ mm	Radial $\Delta K_r$ mm	Angle $\Delta K_w$ degree
220	1.3	0.2	1.2	0.5
265	1.3	0.2	1.2	0.5
290	1.5	0.2	1.2	0.5
320	1.5	0.2	1.2	0.5
360	1.5	0.2	1.2	0.5
420	1.5	0.3	1.3	0.4
465	1.7	0.3	1.3	0.4
520	1.7	0.3	1.4	0.4
560	1.7	0.3	1.4	0.4
580	1.8	0.4	1.5	0.3
680	1.8	0.4	1.5	0.3
770	2.0	0.5	1.5	0.3

The correction factors for different speeds are specified in the following table.

The maximum speed for the respective coupling size and type must be noted!

$$\Delta K_{perm} = \Delta K_{1500} \cdot FKV$$

	Speed in rpm			
	500	1000	1500	3000
Correction factor FKV	1.2	1.1	1.0	0.7

# GENERAL

## Variants of the outer flange

The outer flange of sizes 220 to 680 is designed to fit the connection dimensions of the SAE J620d standard. The centering depth on the connection flange of the machine should be between 4 mm and 6.4 mm maximum.

Type	Size	Flange connection size	Figure
ESN	220	6.5	1
ESN, ESNR	220	7.5	2
	265	8	
	360	11.5	
	465	14	
	580	18	
	680	21	
ESN, ESNR	220	8, 10	3
	265	10, 11.5	
	290	all	
	320	all	
	360	14	
	420	all	
	465	16, 18	
	520	all	
	560	all	
	580	21	
680	24		
ESNR	770	all	
ESD, ESDR	520	all	4
	560	all	
	580	all	
ESD, ESDR	680	21	5
ESD, ESDR	680	24	6
ESDR	770	all	

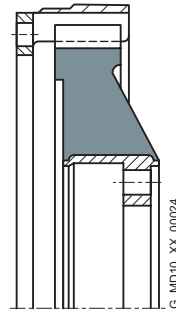

Figure 1

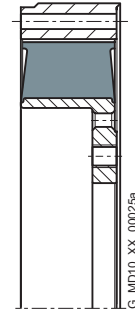

Figure 2

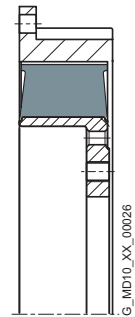

Figure 3

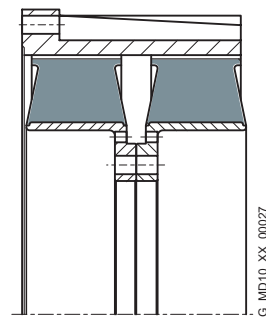

Figure 4

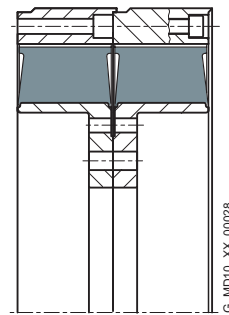

Figure 5

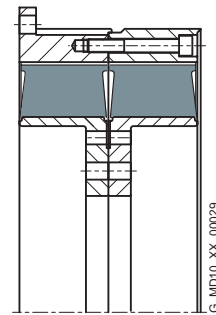
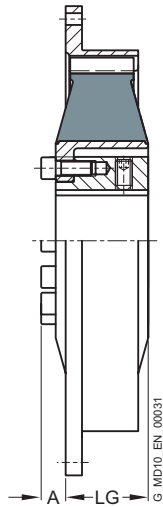

Figure 6





# TYPE ESN



Short version

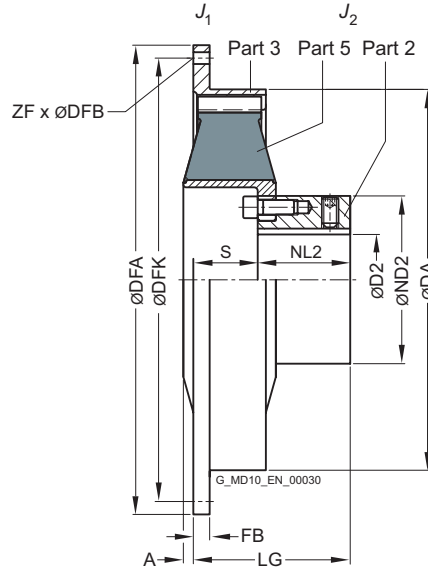

Long version

11

Size	Dimensions in mm											Mass moment of inertia		Article no. <sup>1)</sup>		Weight m kg				
	D2 Keyway DIN 6885 max.	DA	ND2	NL2	short version		long version			Flange connection dimensions					J <sub>1</sub> kgm <sup>2</sup>		J <sub>2</sub> kgm <sup>2</sup>	Type	short version	long version
					A	LG	A	S	LG	SAE size	DFA	DFK	FB	ZF						
220	60	222	98	54	-	-	0	49	103	6.5	215.9	200.0	6	6	8.5	0.008	0.01	-	2LC0220-0AB0	5.8
		237						40	94	7.5	241.3	222.3	33	8	8.5	0.011		-	2LC0220-0AB0	6.1
		222						40	94	8	263.5	244.5	8	6	10.5	0.011		-	2LC0220-0AB0	6.4
		222						40	94	10	314.3	295.3	8	8	10.5	0.017		-	2LC0220-0AB0	6.9
265	65	263	118	65	15	74	3	39	104	8	263.5	244.5	33	6	0.011	0.022	2LC0220-1AA0	2LC0220-1AB0	6.6	
										10	314.3	295.3	10	8	10.5		0.017	2LC0220-1AA0	2LC0220-1AB0	6.9
										11.5	352.4	333.4	10	8	0.024		2LC0220-1AA0	2LC0220-1AB0	7.2	
290	65	290	118	70	18	58	6	36	106	10	314.3	295.3	16	8	0.026	0.026	2LC0220-2AA0	2LC0220-2AB0	9.2	
										11.5	352.4	333.4	16	8	0.036		2LC0220-2AA0	2LC0220-2AB0	10.5	
320	80	318	140	87	15	96	2	70	157	11.5	352.4	333.4	16	8	10.5	0.062	0.061	2LC0220-3AA0	2LC0220-3AB0	19
										14	466.7	438.2	16	8	13	0.18		2LC0220-3AA0	2LC0220-3AB0	20.5
360	90	353.5	160	105	29	92	13	56	161	11.5	352.4	333.4	54	8	10.5	0.065	0.13	2LC0220-4AA0	2LC0220-4AB0	24.5
										14	466.7	438.2	15	8	13	0.18		2LC0220-4AA0	2LC0220-4AB0	27.5
										14	466.7	438.2	18	8	13	0.22		2LC0220-5AA0	2LC0220-5AB0	36
420	100	420	185	102	26	92	10	72	174	16	517.5	489.0	18	8	13	0.32	0.32	2LC0220-5AA0	2LC0220-5AB0	38
										18	571.5	542.9	18	6	17	0.47		2LC0220-5AA0	2LC0220-5AB0	40

### Configurable variants <sup>1)</sup>

- ØD2 Without finished bore  
With finished bore
- Rubber version WN  
NN  
SN  
NX

<sup>1)</sup> To identify complete item numbers specifying the available finish boring options and – if necessary – further order options, please use our configurators on [flender.com](http://flender.com).

➤ For online configuration on [flender.com](http://flender.com), click on the item no.

Size	Dimensions in mm													Mass moment of inertia		➤ Article no. <sup>1)</sup>		Weight <i>m</i> kg		
	D2 Keyway DIN 6885 max.	DA	ND2	NL2	short version		long version			Flange connection dimensions						<i>J</i> <sub>1</sub> kgm <sup>2</sup>	<i>J</i> <sub>2</sub> kgm <sup>2</sup>		Type	
					A	LG	A	S	LG	SAE size	DFA g7	DFK	FB	ZF	DFB				short version	long version
465	120	465	222	125	33	92	2	39	164	14	466.7	438.2	85	8	13	0.31	0.58	2LC0220-6AA0	2LC0220-6AB0	56
										16	517.5	489.0	27	8	13	0.41		2LC0220-6AA0	2LC0220-6AB0	57
										18	571.5	542.9	18	6	17	0.52		2LC0220-6AA0	2LC0220-6AB0	61
520	165	514	250	142	16	159	0	83	225	18	571.5	542.9	18	12	17	0.48	0.93	2LC0220-7AA0	2LC0220-7AB0	55
										21	673.1	641.4	18	12	17	0.95		2LC0220-7AA0	2LC0220-7AB0	60
560	200	560	320	140	30	130	2.5	83	223	18	571.5	542.9	35	12	17	0.85	1.2	2LC0220-8AA0	2LC0220-8AB0	69
										21	673.1	641.4	20	12	17	1.8		2LC0220-8AA0	2LC0220-8AB0	78
580	200	580	316	200	23	215	0	100	300	18	571.5	542.9	104	12	17	0.77	1.8	2LC0221-0AA0	2LC0221-0AB0	100
										21	673.1	641.4	26	12	17	1.2		2LC0221-0AA0	2LC0221-0AB0	105
680	220	682	380	210	24	232	0	102	312	21	673.1	641.4	85	12	17	4.1	5.3	2LC0221-1AA0	2LC0221-1AB0	205
										24	733.4	692.2	20	12	21	5.3		2LC0221-1AA0	2LC0221-1AB0	215

**Configurable variants <sup>1)</sup>**

- ØD2                      Without finished bore  
                                 With finished bore

---

- Rubber version      WN  
                                 NN  
                                 SN  
                                 NX

**Notes**

- The rubber disk element cannot be dismounted until the machines have been moved.
- Weight and mass moments of inertia apply to maximum bore diameters.

**Ordering example**

- ELPEX-S ESN coupling, size 520, WN rubber element version
- Bore ØD2 = 150H7 mm, with keyway to DIN 6885 and set screw, outer flange to SAE J620d size 21

Short version article no.: 2LC0220-7AA09-1JA0-Z M1W

Long version article no.: 2LC0220-7AB09-1JA0-Z M1W

<sup>1)</sup> To identify complete item numbers specifying the available finish boring options and – if necessary – further order options, please use our configurators on [flieder.com](http://flieder.com).

➤ For online configuration on [flieder.com](http://flieder.com), click on the item no.

# TYPE ESNR

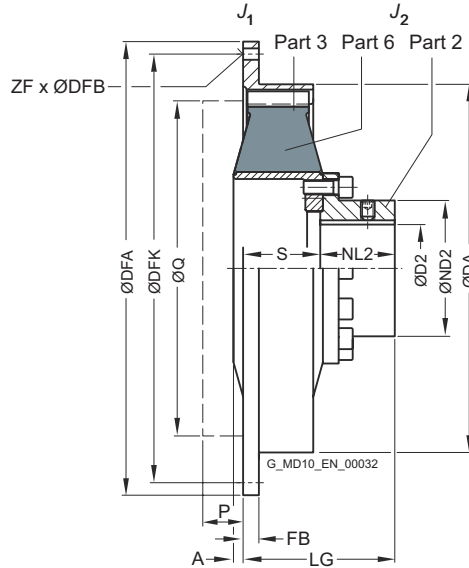

11

Size	Dimensions in mm										Flange connection dimensions					Mass moment of inertia		Article no. <sup>1)</sup>	Weight m kg
	D2 Keyway DIN 6885 max.	DA	ND2	NL2	S	A	P	Q	LG	SAE size	DFA	DFK	FB	ZF	DFB	J <sub>1</sub> kgm <sup>2</sup>	J <sub>2</sub> kgm <sup>2</sup>		
265	50	263	78	65	42	-	10	225	107	8	263.5	244.5	33	6	10.5	0.011	0.022	2LC0220-1AC0	5.0
										10	314.3	295.3	10	8		0.017		2LC0220-1AC0	5.3
										11.5	352.4	333.4	10	8		0.024		2LC0220-1AC0	5.6
290	50	290	78	65	59	2	15	276	124	10	314.3	295.3	16	8	10.5	0.026	0.026	2LC0220-2AC0	8.1
										11.5	352.4	333.4	16	8		0.036		2LC0220-2AC0	8.4
320	65	318	98	87	74	0	20	310	161	11.5	352.4	333.4	16	8	10.5	0.062	0.061	2LC0220-3AC0	13.5
										14	466.7	438.2	16	8		0.18		2LC0220-3AC0	16
360	85	353.5	123	88	77	9	28	314	165	11.5	352.4	333.4	54	8	10.5	0.065	0.13	2LC0220-4AC0	20
										14	466.7	438.2	15	8		0.18		2LC0220-4AC0	23
420	100	420	155	85	93	6	28	409	178	14	466.7	438.2	18	8	13	0.22	0.32	2LC0220-5AC0	31
										16	517.5	489.0	18	8		0.32		2LC0220-5AC0	32
										18	571.5	542.9	18	6		0.47		2LC0220-5AC0	35
465	130	465	190	119	88	-	15	409	207	14	466.7	438.2	85	8	13	0.31	0.58	2LC0220-6AC0	41
										16	517.5	489.0	27	8		0.41		2LC0220-6AC0	42
										18	571.5	542.9	18	6		0.52		2LC0220-6AC0	45

### Configurable variants <sup>1)</sup>

- ØD2                      Without finished bore  
                                    With finished bore

---

- Rubber version      WN  
                                    NN  
                                    SN  
                                    NX

<sup>1)</sup> To identify complete item numbers specifying the available finish boring options and – if necessary – further order options, please use our configurators on [flender.com](http://flender.com).

↗ For online configuration on [flender.com](http://flender.com), click on the item no.

Size	Dimensions in mm															Mass moment of inertia		Article no. <sup>1)</sup>	Weight <i>m</i> kg
	D2 Keyway DIN 6885 max.	DA	ND2	NL2	S	A	P	Q	LG	Flange connection dimensions						<i>J</i> <sub>1</sub> kgm <sup>2</sup>	<i>J</i> <sub>2</sub> kgm <sup>2</sup>		
										SAE size	DFA g7	DFK	FB	ZF	DFB				
520	150	514	227	162	85	-	10	498	247	18	571.5	542.9	18	12	17	0.48	0.93	2LC0220-7AC0	59
										21	673.1	641.4	18	12	17	0.95		2LC0220-7AC0	64
560	150	560	240	180	99	-	10	498	279	18	571.5	542.9	35	12	17	0.85	1.2	2LC0220-8AC0	75
										21	673.1	641.4	20	12	17	1.8		2LC0220-8AC0	85
580	160	580	240	200	102	-	10	498	302	18	571.5	542.9	104	12	17	0.77	1.8	2LC0221-0AC0	80
										21	673.1	641.4	26	12	17	1.2		2LC0221-0AC0	84
680	200	682	300	210	102	-	10	584	312	21	673.1	641.4	85	12	17	4.1	5.3	2LC0221-1AC0	155
										24	733.4	692.2	20	12	21	5.3		2LC0221-1AC0	165
770	260	780	390	255	134	-	10	750	389	-	860.0	820.0	26	32	21	10.7	12	2LC0221-2AC0	330
										-	920.0	880.0	27	32	21	15.4		2LC0221-2AC0	350
											995.0	950.0	27	32	21	20.5	2LC0221-2AC0	375	

**Configurable variants<sup>1)</sup>**

- ØD2                      Without finished bore  
                                  With finished bore

---

- Rubber version      WN  
                                  NN  
                                  SN  
                                  NX

**Notes**

- Weight and mass moments of inertia apply to maximum bore diameters.
- P, Q = required space for radial dismounting of the rubber disk element.

**Ordering example**

- ELPEX-S ESNR coupling, size 320, WN rubber element version
- Bore ØD2 = 50H7 mm, with keyway to DIN 6885 and set screw, outer flange to SAE J620d size 14

Article no.: 2LC0220-3AC09-1FA0-Z M1C

<sup>1)</sup> To identify complete item numbers specifying the available finish boring options and – if necessary – further order options, please use our configurators on [fender.com](http://fender.com).  
 ↗ For online configuration on [fender.com](http://fender.com), click on the item no.

# TYPE ESD

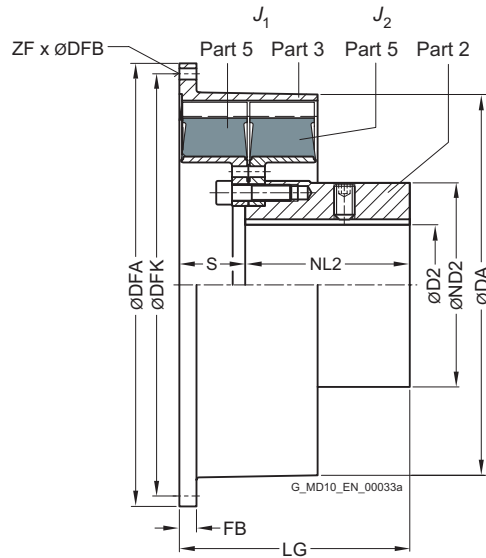

Size	Dimensions in mm							Flange connection dimensions					Mass moment of inertia		Article no. <sup>1)</sup>	Weight <i>m</i> kg
	D2 Keyway DIN 6885 max.	DA	ND2	NL2	S	LG	SAE size	DFA	DFK	FB	ZF	DFB	<i>J</i> <sub>1</sub> kgm <sup>2</sup>	<i>J</i> <sub>2</sub> kgm <sup>2</sup>		
520	165	525	250	174	81	255	18	571.5	542.9	25	12	17	1	1.6	2LC0220-7AD0	85
							21	673.1	641.4	18	12	17	1.5			90
560	170	560	316	210	60	270	18	571.5	542.9	35	12	17	1.7	2.8	2LC0220-8AD0	140
							21	673.1	641.4	25	12	17	2.6			150
580	200	585	310	250	100	350	21	673.1	641.4	26	12	17	2	3.8	2LC0221-0AD0	170
							24	733.4	692.2	26	12	21	2.6			175
680	220	682	380	250	17	267	21	673.1	641.4	85	12	17	8.2	7	2LC0221-1AD0	265
							24	733.4	692.2	20	12	21	9.4			275

### Configurable variants <sup>1)</sup>

- ØD2 Without finished bore  
With finished bore
- Rubber version WN  
NN  
SN  
NX

### Notes

- The rubber disk element cannot be dismantled until the machines have been moved.
- Weight and mass moments of inertia apply to maximum bore diameters.

### Ordering example

- ELPEX-S ESD coupling, size 680, WN rubber element version
- Bore ØD2 = 180H7 mm, with keyway to DIN 6885 and set screw, outer flange to SAE J620d size 24

Article no.: 2LC0221-1AD09-1KA0-Z M2B

<sup>1)</sup> To identify complete item numbers specifying the available finish boring options and – if necessary – further order options, please use our configurators on [flender.com](http://flender.com).

↗ For online configuration on [flender.com](http://flender.com), click on the item no.

# TYPE ESDR

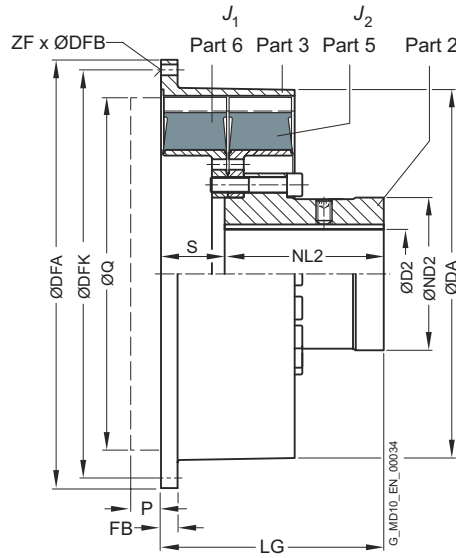

Size	Dimensions in mm								Flange connection dimensions					Mass moment of inertia		Article no. <sup>1)</sup>	Weight <i>m</i> kg	
	D2 Keyway DIN 6885 max.	DA	ND2	NL2	S	P	Q	LG	SAE size	DFA	DFK	FB	ZF	DFB	<i>J</i> <sub>1</sub> kgm <sup>2</sup>			<i>J</i> <sub>2</sub> kgm <sup>2</sup>
520	150	525	227	226	83	10	498	309	18	571.5	542.9	25	12	17	1	1.8	2LC0220-7AE0	105
									21	673.1	641.4	18	12	17	1.5		2LC0220-7AE0	110
560	160	560	240	240	100	10	498	340	18	571.5	542.9	35	12	17	1.7	2.5	2LC0220-8AE0	135
									21	673.1	641.4	25	12	17	2.6		2LC0220-8AE0	140
580	160	585	240	250	100	10	560	350	21	673.1	641.4	26	12	17	2	3.2	2LC0221-0AE0	145
									24	733.4	692.2	26	12	21	2.6		2LC0221-0AE0	150
680	200	682	300	250	102	10	584	352	21	673.1	641.4	85	12	17	8.2	6.5	2LC0221-1AE0	260
									24	733.4	692.2	20	12	21	9.4		2LC0221-1AE0	270
770	260	780	390	300	200	10	750	500	-	860.0	820.0	19	32	-	22.3	20	2LC0221-2AE0	540
									-	920.0	880.0	27	32	21	26		2LC0221-2AE0	555
									-	995.0	950.0	27	32	-	31		2LC0221-2AE0	600

### Configurable variants<sup>1)</sup>

- ØD2 Without finished bore  
With finished bore
- Rubber version WN  
NN  
SN  
NX

### Notes

- Weight and mass moments of inertia apply to maximum bore diameters.
- P, Q = required space for radial dismounting of the rubber disk element.

### Ordering example

- ELPEX-S ESDR coupling, size 560, WN rubber element version
- Bore ØD2 = 120H7 mm, with keyway to DIN 6885 and set screw, outer flange to SAE J620d size 21

Article no.: 2LC0220-8AE09-1JA0-Z M1S

<sup>1)</sup> To identify complete item numbers specifying the available finish boring options and – if necessary – further order options, please use our configurators on [flender.com](http://flender.com).

↗ For online configuration on [flender.com](http://flender.com), click on the item no.

# TYPE ESNW

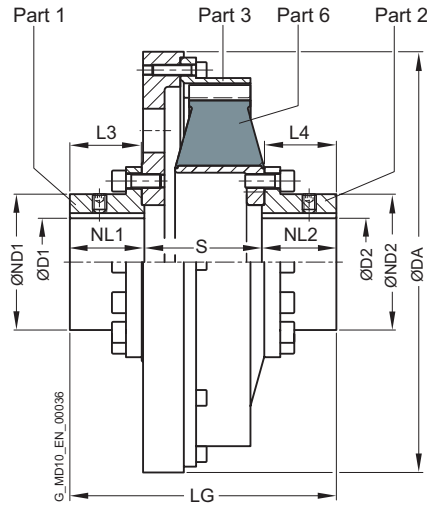

Size	Dimensions in mm								Mass moment of inertia		Article no. <sup>1)</sup>	Weight <i>m</i> kg
	D1/D2 Keyway DIN 6885 max.	DA	ND1/ND2	NL1/NL2	L3	L4	S	LG	<i>J</i> <sub>1</sub> kgm <sup>2</sup>	<i>J</i> <sub>2</sub> kgm <sup>2</sup>		
265	50	275	78	65	62	66	68	198	0.11	0.017	2LC0220-1AG	15
290	50	325	78	65	62	68	89	219	0.21	0.028	2LC0220-2AG	22
320	65	365	98	87	84	92	105	279	0.37	0.042	2LC0220-3AG	32
360	85	365	123	88	85	96	123	299	0.45	0.11	2LC0220-4AG	43
420	100	480	155	85	82	94	134	304	1.5	0.3	2LC0220-5AG	75
465	130	480	190	119	116	119	125	363	1.6	0.54	2LC0220-6AG	89
520	150	585	227	162	159	161	123	447	4	0.94	2LC0220-7AG	155
560	150	585	240	180	174	174	132	492	4.1	1.2	2LC0220-8AG	160
580	160	685	240	200	195	198	145	545	5.5	1.6	2LC0221-0AG	185
680	200	685	300	210	205	201	150	570	12	3.6	2LC0221-1AG	315
770	260	870	390	255	250	253	180	690	27.2	12	2LC0221-2AG	500

## Configurable variants <sup>1)</sup>

• ØD1	Without finished bore With finished bore
• ØD2	Without finished bore With finished bore
• Rubber version	WN NN SN NX

## Notes

- Weight and mass moments of inertia apply to maximum bore diameters.

## Ordering example

- ELPEX-S ESNW coupling, size 520, WN rubber element version
- Bore ØD1 140H7 mm, keyway to DIN 6885 and set screw
- Bore ØD2 120H7 mm, keyway to DIN 6885 and set screw

Article no.: 2LC0220-7AG99-1AA0-Z L1V+M1S

<sup>1)</sup> To identify complete item numbers specifying the available finish boring options and – if necessary – further order options, please use our configurators on [flender.com](http://flender.com).

↗ For online configuration on [flender.com](http://flender.com), click on the item no.



# TYPE ESDW

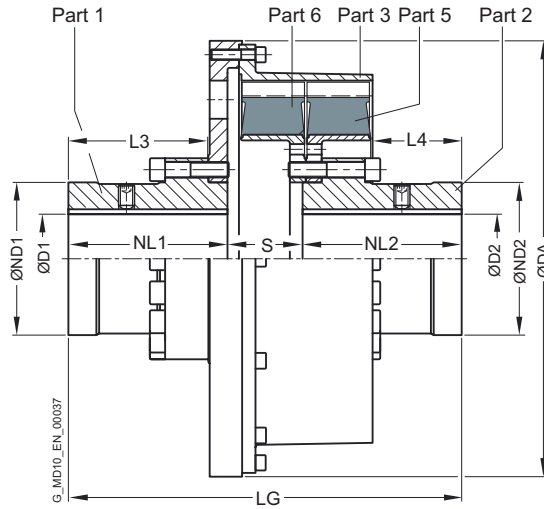

Size	Dimensions in mm								Mass moment of inertia		Article no. <sup>1)</sup>	Weight m kg
	D1/D2 Keyway DIN 6885 max.	DA	ND1/ND2	NL1/NL2	L3	L4	S	LG	J <sub>1</sub> kgm <sup>2</sup>	J <sub>2</sub> kgm <sup>2</sup>		
520	150	585	227	226	201	135	100	552	4.7	1.8	2LC0220-7AH	215
560	160	585	240	240	215	133	114	594	5.4	2.5	2LC0220-8AH	250
580	160	685	240	250	220	140	120	620	10.1	3.2	2LC0221-0AH	300
680	200	685	300	250	218	134	125	625	14.5	6.5	2LC0221-1AH	440
770	260	870	390	300	265	238	220	820	40	20	2LC0221-2AH	720

## Configurable variants <sup>1)</sup>

• ØD1	Without finished bore With finished bore
• ØD2	Without finished bore With finished bore
• Rubber version	WN NN SN NX

## Notes

- Weight and mass moments of inertia apply to maximum bore diameters.

## Ordering example

- ELPEX-S ESDW coupling, size 520, WN rubber element version
- Bore ØD1 140H7 mm, keyway to DIN 6885 and set screw
- Bore ØD2 120H7 mm, keyway to DIN 6885 and set screw

Article no.: 2LC0220-7AH99-1AA0-Z L1V+M1S

<sup>1)</sup> To identify complete item numbers specifying the available finish boring options and – if necessary – further order options, please use our configurators on [flender.com](http://flender.com).

➤ For online configuration on [flender.com](http://flender.com), click on the item no.

# TYPE EST

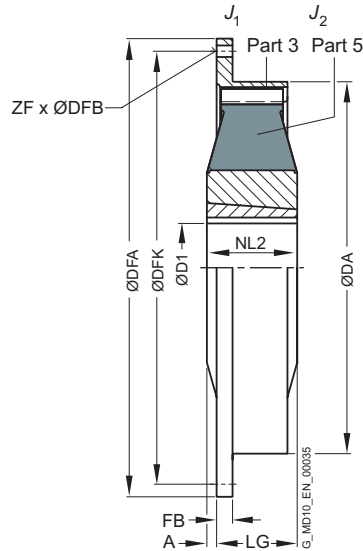

Size	Taper Clamping Bush Size	Dimensions in mm						Flange connection dimensions					Mass moment of inertia		Article no. <sup>1)</sup>	Weight <i>m</i> kg		
		D1 Keyway DIN 6885 min.	max.	DA	NL2	A	LG	SAE size	DFA	DFK	FB	ZF	DFB	<i>J</i> <sub>1</sub> kgm <sup>2</sup>			<i>J</i> <sub>2</sub> kgm <sup>2</sup>	
220	2012	14	50	222	32	0	43	52	6.5	215.9	200.0	6	6	8.5	0.008	0.008	2LC0220-0AF0	3.6
								7.5	241.3	222.3	33	8	8.5	0.008	2LC0220-0AF0		3.5	
								8	263.5	244.5	8	6	10.5	0.011	2LC0220-0AF0		3.7	
								10	314.3	295.3	8	8	10.5	0.020	2LC0220-0AF0		4.2	
265	2517	16	60	263	45	3	42	8	263.5	244.5	33	6	0.011	0.019	2LC0220-1AF0	5.9		
								10	314.3	295.3	10	8	10.5		0.017	2LC0220-1AF0	6.2	
								11.5	352.4	333.4	10	8	0.024		2LC0220-1AF0	6.5		
290	2517	16	60	290	64	6	58	10	314.3	295.3	16	8	0.026	0.026	2LC0220-2AF0	8.5		
								11.5	352.4	333.4	16	8	10.5		0.036	2LC0220-2AF0	8.8	
320	3030	35	75	318	76	2	73	11.5	352.4	333.4	16	8	0.062	0.06	2LC0220-3AF0	14		
								14	466.7	438.2	16	8	13		0.18	2LC0220-3AF0	17	
360	3535	35	90	353.5	89	13	76	11.5	352.4	333.4	54	8	10.5	0.065	0.13	2LC0220-4AF0	21	
								14	466.7	438.2	15	8	13	0.18		2LC0220-4AF0	24	
								14	466.7	438.2	18	8	13	0.22		2LC0220-5AF0	37	
420	4040	40	100	420	102	10	92	16	517.5	489.0	18	8	13	0.32	0.33	2LC0220-5AF0	38	
								18	571.5	542.9	18	6	17	0.47		2LC0220-5AF0	41	
								14	466.7	438.2	85	8	13	0.31		2LC0220-6AF0	63	
465	4545	55	110	465	115	28	87	16	517.5	489.0	27	8	13	0.41	0.76	2LC0220-6AF0	64	
								18	571.5	542.9	18	6	17	0.52		2LC0220-6AF0	68	

### Configurable variants <sup>1)</sup>

- ØD1 Without finished bore  
With finished bore
- Rubber version WN  
NN  
SN  
NX

### Notes

- The rubber disk element cannot be dismantled until the machines have been moved.
- Weight and mass moments of inertia apply to maximum bore diameters.

### Ordering example

- ELPEX-S EST coupling, size 265, WN rubber element version, with Taper clamping bush size 2517
- Bore ØD2 = 30 mm, outer flange to SAE J620d size 10

Article no.: 2LC0220-1AF99-1DA0-Z M05

<sup>1)</sup> To identify complete item numbers specifying the available finish boring options and – if necessary – further order options, please use our configurators on [flender.com](http://flender.com).

↗ For online configuration on [flender.com](http://flender.com), click on the item no.

# SPARE AND WEAR PARTS

## Rubber disk elements

Size	↗ Article No. set of rubber disk elements for a coupling					
	Coupling type EST		ESN	ESNR, ESNW	ESD	ESDR, ESDW
	without Taper clamping bush	with Taper clamping bush				
<b>WN rubber version</b>						
220	2LC0220-0XL10-1AA0	2LC0220-0XL90-1AA0	2LC0220-0XJ00-1AA0			
265	2LC0220-1XL10-1AA0	2LC0220-1XL90-1AA0	2LC0220-1XJ00-1AA0	2LC0220-1XM00-1AA0		
290	2LC0220-2XL10-1AA0	2LC0220-2XL90-1AA0	2LC0220-2XJ00-1AA0	2LC0220-2XM00-1AA0		
320	2LC0220-3XL10-1AA0	2LC0220-3XL90-1AA0	2LC0220-3XJ00-1AA0	2LC0220-3XM00-1AA0		
360	2LC0220-4XL10-1AA0	2LC0220-4XL90-1AA0	2LC0220-4XJ00-1AA0	2LC0220-4XM00-1AA0		
420	2LC0220-5XL10-1AA0	2LC0220-5XL90-1AA0	2LC0220-5XJ00-1AA0	2LC0220-5XM00-1AA0		
465	2LC0220-6XL10-1AA0	2LC0220-6XL90-1AA0	2LC0220-6XJ00-1AA0	2LC0220-6XM00-1AA0		
520			2LC0220-7XJ00-1AA0	2LC0220-7XM00-1AA0	2LC0220-7XK00-1AA0	2LC0220-7XN00-1AA0
560			2LC0220-8XJ00-1AA0	2LC0220-8XM00-1AA0	2LC0220-8XK00-1AA0	2LC0220-8XN00-1AA0
580			2LC0221-0XJ00-1AA0	2LC0221-0XM00-1AA0	2LC0221-0XK00-1AA0	2LC0221-0XN00-1AA0
680			2LC0221-1XJ00-1AA0	2LC0221-1XM00-1AA0	2LC0221-1XK00-1AA0	2LC0221-1XN00-1AA0
770				2LC0221-2XM00-1AA0		2LC0221-2XN00-1AA0
<b>NN rubber version</b>						
220	2LC0220-0XL10-2AA0	2LC0220-0XL90-2AA0	2LC0220-0XJ00-2AA0			
265	2LC0220-1XL10-2AA0	2LC0220-1XL90-2AA0	2LC0220-1XJ00-2AA0	2LC0220-1XM00-2AA0		
290	2LC0220-2XL10-2AA0	2LC0220-2XL90-2AA0	2LC0220-2XJ00-2AA0	2LC0220-2XM00-2AA0		
320	2LC0220-3XL10-2AA0	2LC0220-3XL90-2AA0	2LC0220-3XJ00-2AA0	2LC0220-3XM00-2AA0		
360	2LC0220-4XL10-2AA0	2LC0220-4XL90-2AA0	2LC0220-4XJ00-2AA0	2LC0220-4XM00-2AA0		
420	2LC0220-5XL10-2AA0	2LC0220-5XL90-2AA0	2LC0220-5XJ00-2AA0	2LC0220-5XM00-2AA0		
465	2LC0220-6XL10-2AA0	2LC0220-6XL90-2AA0	2LC0220-6XJ00-2AA0	2LC0220-6XM00-2AA0		
520			2LC0220-7XJ00-2AA0	2LC0220-7XM00-2AA0	2LC0220-7XK00-2AA0	2LC0220-7XN00-2AA0
560			2LC0220-8XJ00-2AA0	2LC0220-8XM00-2AA0	2LC0220-8XK00-2AA0	2LC0220-8XN00-2AA0
580			2LC0221-0XJ00-2AA0	2LC0221-0XM00-2AA0	2LC0221-0XK00-2AA0	2LC0221-0XN00-2AA0
680			2LC0221-1XJ00-2AA0	2LC0221-1XM00-2AA0	2LC0221-1XK00-2AA0	2LC0221-1XN00-2AA0
770				2LC0221-2XM00-2AA0		2LC0221-2XN00-2AA0
<b>SN rubber version</b>						
220	2LC0220-0XL10-3AA0	2LC0220-0XL90-3AA0	2LC0220-0XJ00-3AA0			
265	2LC0220-1XL10-3AA0	2LC0220-1XL90-3AA0	2LC0220-1XJ00-3AA0	2LC0220-1XM00-3AA0		
290	2LC0220-2XL10-3AA0	2LC0220-2XL90-3AA0	2LC0220-2XJ00-3AA0	2LC0220-2XM00-3AA0		
320	2LC0220-3XL10-3AA0	2LC0220-3XL90-3AA0	2LC0220-3XJ00-3AA0	2LC0220-3XM00-3AA0		
360	2LC0220-4XL10-3AA0	2LC0220-4XL90-3AA0	2LC0220-4XJ00-3AA0	2LC0220-4XM00-3AA0		
420	2LC0220-5XL10-3AA0	2LC0220-5XL90-3AA0	2LC0220-5XJ00-3AA0	2LC0220-5XM00-3AA0		
465	2LC0220-6XL10-3AA0	2LC0220-6XL90-3AA0	2LC0220-6XJ00-3AA0	2LC0220-6XM00-3AA0		
520			2LC0220-7XJ00-3AA0	2LC0220-7XM00-3AA0	2LC0220-7XK00-3AA0	2LC0220-7XN00-3AA0
560			2LC0220-8XJ00-3AA0	2LC0220-8XM00-3AA0	2LC0220-8XK00-3AA0	2LC0220-8XN00-3AA0
580			2LC0221-0XJ00-3AA0	2LC0221-0XM00-3AA0	2LC0221-0XK00-3AA0	2LC0221-0XN00-3AA0
680			2LC0221-1XJ00-3AA0	2LC0221-1XM00-3AA0	2LC0221-1XK00-3AA0	2LC0221-1XN00-3AA0
770				2LC0221-2XM00-3AA0		2LC0221-2XN00-3AA0
<b>NX rubber version</b>						
220	2LC0220-0XL10-4AA0	2LC0220-0XL90-4AA0	2LC0220-0XJ00-4AA0			
265	2LC0220-1XL10-4AA0	2LC0220-1XL90-4AA0	2LC0220-1XJ00-4AA0	2LC0220-1XM00-4AA0		
290	2LC0220-2XL10-4AA0	2LC0220-2XL90-4AA0	2LC0220-2XJ00-4AA0	2LC0220-2XM00-4AA0		
320	2LC0220-3XL10-4AA0	2LC0220-3XL90-4AA0	2LC0220-3XJ00-4AA0	2LC0220-3XM00-4AA0		
360	2LC0220-4XL10-4AA0	2LC0220-4XL90-4AA0	2LC0220-4XJ00-4AA0	2LC0220-4XM00-4AA0		
420	2LC0220-5XL10-4AA0	2LC0220-5XL90-4AA0	2LC0220-5XJ00-4AA0	2LC0220-5XM00-4AA0		
465	2LC0220-6XL10-4AA0	2LC0220-6XL90-4AA0	2LC0220-6XJ00-4AA0	2LC0220-6XM00-4AA0		
520			2LC0220-7XJ00-4AA0	2LC0220-7XM00-4AA0	2LC0220-7XK00-4AA0	2LC0220-7XN00-4AA0
560			2LC0220-8XJ00-4AA0	2LC0220-8XM00-4AA0	2LC0220-8XK00-4AA0	2LC0220-8XN00-4AA0
580			2LC0221-0XJ00-4AA0	2LC0221-0XM00-4AA0	2LC0221-0XK00-4AA0	2LC0221-0XN00-4AA0
680			2LC0221-1XJ00-4AA0	2LC0221-1XM00-4AA0	2LC0221-1XK00-4AA0	2LC0221-1XN00-4AA0
770				2LC0221-2XM00-4AA0		2LC0221-2XN00-4AA0

### Notes

- The ELPEX-S coupling rubber disk elements are wear parts. The service life depends on the operating conditions.



# HIGHLY FLEXIBLE COUPLINGS – ELPEX SERIES

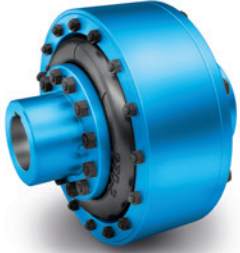

<b>General</b>	<b>12/3</b>
Benefits	12/3
Application	12/3
Design and configurations	12/4
Configuration	12/5
Technical specifications	12/7
-----	
<b>Type ENG</b>	<b>12/8</b>
-----	
<b>Type ENGS – with fail-safe device</b>	<b>12/10</b>
-----	
<b>Types EFG</b>	<b>12/12</b>
-----	
<b>Types EFGS – with fail-safe device</b>	<b>12/14</b>
-----	
<b>Spare and wear parts</b>	<b>12/16</b>
-----	



ELPEX  
**FLENDER**



# GENERAL

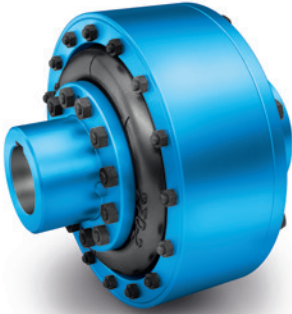

ELPEX couplings are highly torsionally flexible and free of torsional backlash. Because of their low torsional stiffness and damping capacity, ELPEX couplings are especially suitable for coupling machines with a very non uniform torque pattern. ELPEX couplings are also suitable for connecting machines with high shaft misalignment. Standard ELPEX coupling types are designed as shaft-shaft connections or flange-shaft connections. Application-related types can be implemented on request.

## Benefits

The ELPEX coupling is suitable for horizontal and vertical mounting positions or mounting at any required angle. The coupling parts can be arranged as required on the shafts to be connected.

The split flexible rings can be changed without having to move the coupled machines.

The flexible rings are mounted without backlash and give the coupling progressive torsional stiffness, i.e. torsional stiffness increases in proportion to coupling load.

The ELPEX coupling is especially suitable for reversing operation or operation with changing directions of load.

The coupling is delivered preassembled. The flexible rings are completely assembled. On the type ENG, the coupling halves have to be bolted together after the hub has been mounted. On the type EFG, after mounting the coupling hub, only the outer flange has to be connected to the machine.

Outer flanges with different connection dimensions are available for the type EFG.

If the flexible rings are irreparably damaged or worn, the metal parts can rotate freely against one another, they are not in contact with one another.

## Application

The ELPEX coupling is available in 9 sizes with a nominal torque of between 1600 Nm and 90000 Nm. The coupling is suitable for ambient temperatures of between -40 °C and +80 °C.

The ELPEX coupling is frequently used for high-quality drives which have to guarantee very long service life in harsh operating conditions.

Examples of applications are mill drives in the cement industry, marine main and secondary drives or drives on large excavators powered by an electric motor or diesel engine.

# GENERAL

## Design and configurations

The ELPEX coupling's transmission characteristic is determined essentially by the flexible rings. The flexible rings are manufactured from a natural rubber mixture with a multiply fabric lining. The flexible rings are split so that they can be changed without having to move the coupled machines.

The flexible rings are fastened to the hub with a clamping ring and to the outer flange with a clamping ring, using pins and bolts.

On the EFG type, the outer flange is designed with connection dimensions for connection to e.g. a diesel engine flywheel. On ENG types, the outer flange is fitted to a second hub part, which then enables the shaft-shaft connection.

## Materials

	Type	Cast iron	Steel
Hub part 1		Grey cast iron EN-GJL-250	Steel
Hub part 2		Steel	Steel
Retaining ring, outer ENG, ENGS		Grey cast iron EN-GJL-250	Steel
Outer flange EFG, EFGS		Grey cast iron EN-GJL-250	Steel

## Flexible ring materials

Material/Description	Hardness	Marking	Ambient temperature
Natural rubber	70 ShoreA	Size - 2	-40 ... +80 °C

## ELPEX coupling types

Type	Description
ENG	Coupling as shaft-shaft connection
EFG	Coupling as flange-shaft connection
ENGS	as ENG with fail-safe device
EFGS	as EFG with fail-safe device

Further application-specific coupling types are available. Dimension sheets for and information on these are available on request.

The following versions have already been implemented a number of times:

- ELPEX coupling with brake drum, brake disk or flywheel mass
- ELPEX coupling with axial backlash limiter
- ELPEX coupling with adapter
- ELPEX coupling in combination with a safety slip clutch
- ELPEX coupling for engaging/disengaging during stand-still ELPEX coupling as part of a coupling combination

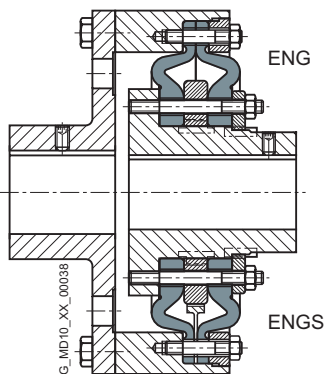

Types ENG/ENGS

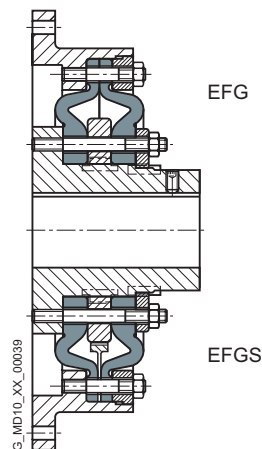

Types EFG/EFGS



### Fail-safe device of ELPEX coupling

Types ENGS and EFGS are provided with a fail-safe device. In normal operation the torsion angle of the flexible rings is smaller than the gap between the cams. In normal operation there is no metal-metal contact. If the flexible rings fail, cams transmit the torque from the inner part and outer part. These enable the coupling to be used in emergency mode for a short time. This option is frequently required e.g. in the case of marine drives.

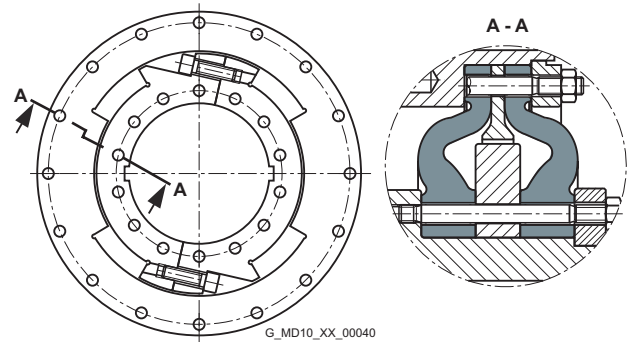

Fail-safe device

### Configuration

#### Coupling selection

The ELPEX coupling is especially suitable for rough operating environments. An application factor lower than that in **Chapter introduction** is therefore sufficient for all applications.

In the case of machines which excite torsional vibration, Flender urgently recommends carrying out a torsional vibration calculation or measuring the coupling load occurring in the drive.

#### Coupling load in continuous operation

The operating principles of the driving and driven machines are divided into categories and the application factor FB derived from these in accordance with DIN 3990-1.

#### Examples of torque characteristic in driven machines:

- uniform with moderate shock loads:  
Generators, fans, blowers

---

- non uniform: Reciprocating compressors, mixers, conveyor systems

---

- very rough: crushers, excavators, presses, mills

Application factor FB	Torque characteristic of the driven machine		
	uniform with moderate shock loads	non uniform	very rough
Electric motors, hydraulic motors, gas and water turbines	1.0	1.3	1.4
Internal-combustion engines	1.3	1.4	1.6

Temperature factor FT		Temperature $T_a$ on the coupling				
Coupling	Elastomer material	-40 up to -30 °C	-30 up to +50 °C	up to 60 °C	up to 70 °C	up to 80 °C
ELPEX	NR	1.1	1.0	1.25	1.40	1.60

NR = Natural rubber mixture

Coupling size  $T_{KN} \geq T_N \cdot FB \cdot FT$

# GENERAL

## Coupling load under maximum and overload conditions

The maximum torque is the highest load acting on the coupling in normal operation.

Maximum torques at a frequency of up to 25 times an hour are permitted and must be lower than the maximum coupling torque. Examples of maximum torque conditions are: Starting operations, stopping operations or usual operating conditions with maximum load.

$$T_{K_{\max}} \geq T_{\text{Max}} \cdot FT$$

Overload torques are maximum loads which occur only in combination with special, infrequent operating conditions. Examples of overload torque conditions are: Motor short circuit, emergency stop or blocking because of component breakage. Overload torques at a frequency of once a month are permitted and must be lower than the maximum overload torque of the coupling. The overload condition may last only a short while, i.e. fractions of a second.

$$T_{K_{OL}} \geq T_{OL} \cdot FT$$

## Coupling load due to dynamic torque load

Applying the frequency factor FF, the dynamic torque load must be lower than the coupling fatigue torque.

Dynamic torque load

$$T_{KW} \geq T_W \cdot FT \cdot FF$$

Frequency of the dynamic torque load

$$f_{\text{err}} \leq 10 \text{ Hz frequency factor } FF = 1.0$$

Frequency of the dynamic torque load

$$f_{\text{err}} > 10 \text{ Hz frequency factor } FF = \sqrt{(f_{\text{err}}/10 \text{ Hz})}$$

## Checking the maximum speed

For all load situations  $n_{K_{\max}} \geq n_{\text{max}}$

## Checking permitted shaft misalignment and restorative forces

For all load situations, the actual shaft misalignment must be less than the permitted shaft misalignment.

## Checking bore diameter, mounting geometry and coupling design

The check must be made on the basis of the dimension tables. On request, couplings with adapted geometry can be provided.

## Checking shaft-hub connection

For any information on this, please refer to **Page E/20**.

## Checking low temperature and chemically aggressive environment

The permitted coupling temperature is specified in the Temperature Factor FT table. In the case of chemically aggressive environments, please consult the manufacturer.

## Technical specifications

Power ratings of the ELPEX series										
Size	Rated torque $T_{KN}$ Nm	Maximum torque $T_{Kmax}$ Nm	Overload torque $T_{KOL}$ Nm	Fatigue torque $T_{KW}$ Nm	Dynamic torsional stiffness for 100 % load $C_{Tdyn}$ kNm/rad	Stiffness		Permitted shaft misalignment at speed $n = 1500$ rpm		
						Axial $C_a$ N/mm	Radial $C_r$ mm	Axial $\Delta K_a$ mm	Radial $\Delta K_r$ mm	Angle $\Delta K_w$ °
270	1600	4800	6400	640	22	660	770	2.2	2.2	0.2
320	2800	8400	11200	1120	38	780	910	2.6	2.6	0.2
375	4500	13500	18000	1800	63	970	1130	3	3	0.2
430	7100	21300	28400	2840	97	1160	1350	3.4	3.4	0.2
500	11200	33600	44800	4480	155	1410	1630	3.8	3.8	0.2
590	18000	54000	72000	7200	240	1710	1990	4.2	4.2	0.2
690	28000	84000	112000	11200	365	2060	2390	4.6	4.6	0.2
840	45000	135000	180000	18000	685	2570	2990	5	5	0.2
970	90000	270000	360000	36000	1100	3020	3510	5.5	5.5	0.2

### Torsional stiffness and damping

The dynamic torsional stiffness is load-dependent and increases in proportion to capacity utilization. The values specified in the selection table apply to a capacity utilization of 100 %. The following table shows the correction factors for different rated loads.

$$C_{Tdyn} = C_{Tdyn 100\%} \cdot FK_C$$

	Load $T_N / T_{KN}$						
	20%	50%	60%	70%	80%	100%	200%
Correction factor FK <sub>C</sub>	0.3	0.56	0.65	0.74	0.82	1	1.9

### The damping coefficient is $\Psi = 1.1$

Torsional stiffness also depends on the ambient temperature and the frequency and amplitude of the torsional vibration excitation. More precise torsional stiffness and damping parameters on request.

With flexible couplings the manufacturing process of the rubber elements and their aging primarily influence the stiffness value  $C_{Tdyn}$ . For this reason calculation must be made with a tolerance for the dynamic stiffness of  $\pm 20\%$ . The specified damping coefficient  $\Psi$  is a minimum value with the result that the damping performance of the coupling corresponds at least to the specified value.

### Permitted shaft misalignment

The permitted shaft misalignment depends on the operating speed. As the speed increases, lower shaft misalignment values are permitted. The correction factors for different speeds are specified in the following table. The maximum speed for the respective coupling size must be noted!

$$\Delta K_{perm} = \Delta K_{1500} \cdot FK_V$$

	Speed in rpm			
	500	1000	1500	3000
Correction factor FK <sub>V</sub>	1.6	1.25	1.0	0.7

# TYPE ENG

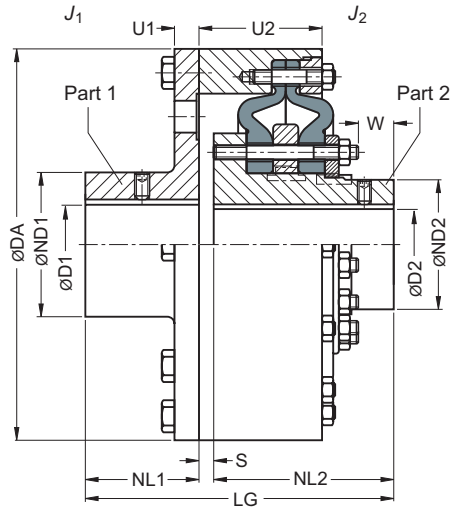

Sizes 270 ... 430

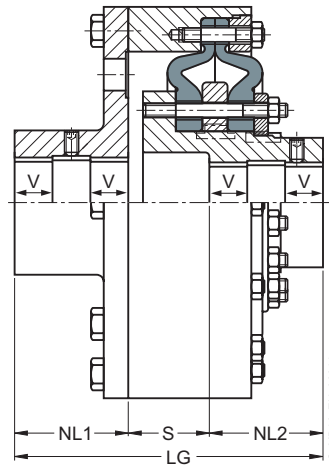

Sizes 500 ... 970

Size	Rated torque $T_{KN}$ Nm	Maximum speed		Dimensions in mm																Mass moment of inertia		Article no. <sup>1)</sup>		Weight $m$ kg
		$n_{Kmax}$ rpm	$n_{Kmax}$ rpm	Keyway DIN 6885				DA	ND1	ND2	NL1	NL2	S	U1	U2	W	LG	$J_1$ kgm <sup>2</sup>	$J_2$ kgm <sup>2</sup>	Cast iron	Steel			
270	1600	3000	4250	45	80	45	70	270	128	94	80	155	10	14	86	42	245	0.21	0.037	2LC0200-3AF	2LC0200-3AL	29		
320	2800	2500	3600	55	100	55	85	320	160	115	100	180	6	16	97.5	48	286	0.49	0.082	2LC0200-4AF	2LC0200-4AL	50		
375	4500	2100	3100	65	115	65	105	375	184	143	120	205	10	18	111.8	62	335	1.0	0.21	2LC0200-5AF	2LC0200-5AL	80		
430	7100	1900	2650	75	130	75	120	430	208	165	140	235	8	22	126	68	383	2.0	0.37	2LC0200-6AF	2LC0200-6AL	113		
500	11200	1600	2300	90	150	90	150	500	240	202	160	160	112	25	139.7	80	432	3.9	0.85	2LC0200-7AF	2LC0200-7AL	174		
590	18000	1360	2000	100	140	100	170	590	224	230	190	190	130	28	162.7	95	510	8.2	1.7	2LC0200-8AF	2LC0200-8AL	254		
				140	180		224		16.3									350						
690	28000	1200	1650	110	140	110	200	690	288	278	220	220	140	32	175.6	102	580	16.8	3.7	2LC0201-0AF	2LC0201-0AL	370		
				180	210		336		16.9									385						
840	45000	1000	1350	140	180	140	240	840	288	340	280	280	125	42	231	105	685	49	11	2LC0201-1AF	2LC0201-1AL	700		
				180	220		352		50									725						
970	90000	850	1180	160	200	160	280	970	320	384	390	350	350	167	70	290	137	867	104	26	2LC0201-2AF	2LC0201-2AL	1265	
				200	240		448		106										1310					
				240	280				512									110				1350		
				280	320													115				1410		

### Configurable variants <sup>1)</sup>

- ØD1 Without finished bore  
With finished bore
- ØD2 Without finished bore  
With finished bore

<sup>1)</sup> To identify complete item numbers specifying the available finish boring options and – if necessary – further order options, please use our configurators on [flender.com](http://flender.com).

↗ For online configuration on [flender.com](http://flender.com), click on the item no.

## Notes

---

- The hub diameter of the component part is assigned according to the diameter of the finished bore. Where bore diameters overlap, the component with the smaller hub diameter is always selected.
- Weights and mass moments of inertia apply to cast iron version with maximum bore.
- From size 500, the bores D1 and D2 are each provided with a recess of  $D = +1$  mm halfway along the hub.  $V \approx 1/3$  NL.

## Ordering example

---

- ELPEX ENG coupling, size 690, cast iron version
- Bore  $\varnothing D1 = 180H7$  mm with keyway to DIN 6885 and set screw, the hub diameter  $ND1 = 288$  mm is thus assigned
- Bore  $\varnothing D2 = 200H7$  mm with keyway to DIN 6885 and set screw, the hub diameter  $ND2 = 278$  mm is thus assigned

Article no.: **2LC0201-0AF99-0AA0-Z L2B+M2D**

---

<sup>1)</sup> To identify complete item numbers specifying the available finish boring options and – if necessary – further order options, please use our configurators on [flender.com](https://www.flender.com).

➤ For online configuration on [flender.com](https://www.flender.com), click on the item no.

# TYPE ENGS

with fail-safe device

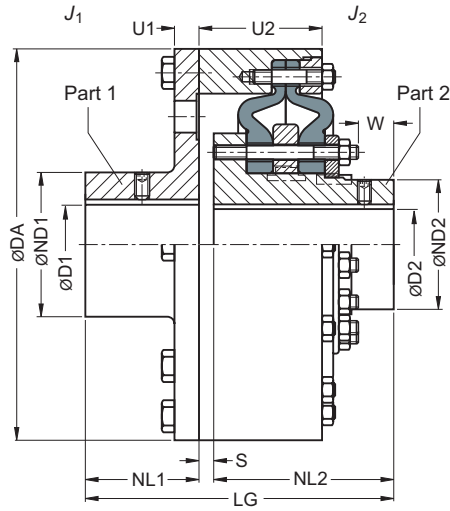

Sizes 270 ... 430

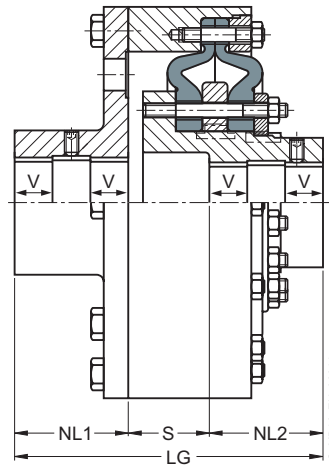

Sizes 500 ... 970

Size	Rated torque $T_{KN}$ Nm	Maximum speed		Dimensions in mm																Mass moment of inertia		Article no. <sup>1)</sup>		Weight $m$ kg
		$n_{Kmax}$ rpm	$n_{Kmax}$ rpm	Keyway DIN 6885				DA	ND1	ND2	NL1	NL2	S	U1	U2	W	LG	$J_1$ kgm <sup>2</sup>	$J_2$ kgm <sup>2</sup>	Cast iron	Steel			
270	1600	3000	4250	45	80	45	70	270	128	94	80	155	10	14	86	42	245	0.21	0.037	2LC0200-3AG	2LC0200-3AM	29		
320	2800	2500	3600	55	100	55	85	320	160	115	100	180	6	16	97.5	48	286	0.49	0.082	2LC0200-4AG	2LC0200-4AM	50		
375	4500	2100	3100	65	115	65	105	375	184	143	120	205	10	18	111.8	62	335	1.0	0.21	2LC0200-5AG	2LC0200-5AM	80		
430	7100	1900	2650	75	130	75	120	430	208	165	140	235	8	22	126	68	383	2.0	0.37	2LC0200-6AG	2LC0200-6AM	113		
500	11200	1600	2300	90	150	90	150	500	240	202	160	160	112	25	139.7	80	432	3.9	0.85	2LC0200-7AG	2LC0200-7AM	174		
590	18000	1360	2000	100	140	100	170	590	224	230	190	190	130	28	162.7	95	510	8.2	1.7	2LC0200-8AG	2LC0200-8AM	254		
				140	180		224		16.3									350						
690	28000	1200	1650	110	140	110	200	690	288	278	220	220	140	32	175.6	102	580	16.8	3.7	2LC0201-0AG	2LC0201-0AM	370		
				180	210		336		16.9									385						
840	45000	1000	1350	140	180	140	240	840	288	340	280	280	125	42	231	105	685	49	11	2LC0201-1AG	2LC0201-1AM	700		
				180	220		352		50									725						
970	90000	850	1180	160	200	160	280	970	320	384	390	350	350	167	70	290	137	867	104	26	2LC0201-2AG	2LC0201-2AM	1265	
				200	240		448		106										1310					
				240	280				512									110				1350		
				280	320													115				1410		

## Configurable variants <sup>1)</sup>

- ØD1 Without finished bore  
With finished bore
- ØD2 Without finished bore  
With finished bore

<sup>1)</sup> To identify complete item numbers specifying the available finish boring options and – if necessary – further order options, please use our configurators on [flender.com](http://flender.com).

↗ For online configuration on [flender.com](http://flender.com), click on the item no.

## Notes

---

- The hub diameter of the component part is assigned according to the diameter of the finished bore. Where bore diameters overlap, the component with the smaller hub diameter is always selected.
- Weights and mass moments of inertia apply to cast iron version with maximum bore.
- From size 500, the bores D1 and D2 are each provided with a recess of  $D = +1$  mm halfway along the hub.  $V \approx 1/3$  NL.

## Ordering example

---

- ELPEX ENGS coupling, size 690, cast iron version
- Bore  $\varnothing D1 = 180H7$  mm with keyway to DIN 6885 and set screw, the hub diameter  $ND1 = 288$  mm is thus assigned
- Bore  $\varnothing D2 = 200H7$  mm with keyway to DIN 6885 and set screw, the hub diameter  $ND2 = 278$  mm is thus assigned

Article no.: **2LC0201-0AG99-0AA0-Z L2B+M2D**

---

<sup>1)</sup> To identify complete item numbers specifying the available finish boring options and – if necessary – further order options, please use our configurators on [flender.com](https://www.flender.com).

➤ For online configuration on [flender.com](https://www.flender.com), click on the item no.

# TYPES EFG

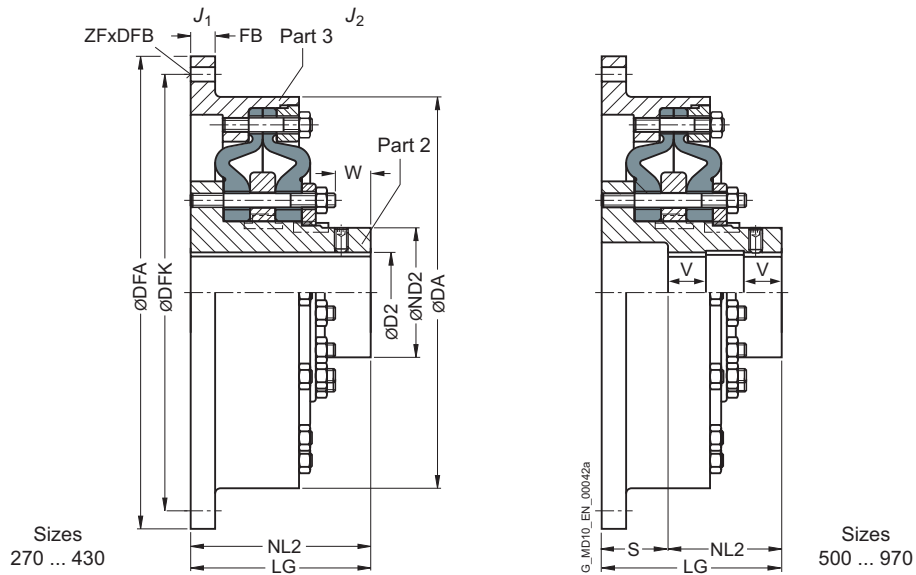

12

Size	Rated torque $T_{KN}$ Nm	Maximum speed		Dimensions in mm										Mass moment of inertia		Article no. <sup>1)</sup>		Weight $m$ kg			
		Type Cast iron	Steel	D2 Keyway DIN 6885 min.   max.	DA	ND2	NL2	S	W	LG	Flange connection dimensions <sup>2)</sup>					$J_1$ kgm <sup>2</sup>	$J_2$ kgm <sup>2</sup>		Type	Cast iron	Steel
											DFA	DFK	FB	ZF	DFB						
270	1600	3000	4250	45	70	270	94	155	-	42	155	466.7 <sub>97</sub> <sup>2)</sup>	438.2 <sup>2)</sup>	12	8	13	0.47	-0.037	2LC0200-3AB2	2LC0200-3AJ2	27
												325 <sub>6</sub>	300	8	14	0.16	2LC0200-3AB1		2LC0200-3AJ1	19	
320	2800	2500	3600	55	85	320	115	180	-	48	180	517.5 <sub>97</sub> <sup>2)</sup>	489 <sup>2)</sup>	14	8	13	0.87	-0.082	2LC0200-4AB2	2LC0200-4AJ2	42
												392 <sub>6</sub>	360	8	18	0.39	2LC0200-4AB1		2LC0200-4AJ1	33.5	
375	4500	2100	3100	65	105	375	143	205	-	62	205	571.5 <sub>97</sub> <sup>2)</sup>	542.9 <sup>2)</sup>	16	6	17	1.5	-0.21	2LC0200-5AB2	2LC0200-5AJ2	65
												448 <sub>6</sub>	415	8	18	0.78	2LC0200-5AB1		2LC0200-5AJ1	53	
430	7100	1900	2650	75	120	430	165	235	-	68	235	673.1 <sub>97</sub> <sup>2)</sup>	641.4 <sup>2)</sup>	20	12	17	3.4	-0.37	2LC0200-6AB2	2LC0200-6AJ2	100
												515 <sub>6</sub>	475	8	22	1.5	2LC0200-6AB1		2LC0200-6AJ1	78	
500	11200	1600	2300	90	150	500	202	160	100	80	260	673.1 <sub>97</sub> <sup>2)</sup>	641.4 <sup>2)</sup>	20	12	17	4.0	-0.85	2LC0200-7AB2	2LC0200-7AJ2	150
												585 <sub>6</sub>	545	10	22	2.7	2LC0200-7AB1		2LC0200-7AJ1	140	

### Configurable variants <sup>1)</sup>

- ØD2 Without finished bore  
With finished bore

<sup>1)</sup> To identify complete item numbers specifying the available finish boring options and – if necessary – further order options, please use our configurators on [flender.com](http://flender.com).

<sup>2)</sup> The upper line for the flange connection dimensions complies with standard SAE J620d or DIN 6288.

↗ For online configuration on [flender.com](http://flender.com), click on the item no.



Size	Rated torque $T_{KN}$ Nm	Maximum speed		Dimensions in mm										Mass moment of inertia		Article no. <sup>1)</sup>		Weight $m$ kg			
		Type Cast iron $n_{Kmax}$ rpm	Steel $n_{Kmax}$ rpm	D2 Keyway DIN 6885 min.   max.	DA	ND2	NL2	S	W	LG	Flange connection dimensions <sup>2)</sup>					$J_1$ kgm <sup>2</sup>	$J_2$ kgm <sup>2</sup>		Type Cast iron	Steel	
											DFA	DFK	FB	ZF	DFB						
590	18000	1350	2000	100	170	590	230	190	120	95	310	$\frac{733.4_{g7}^{21}}{692_{j6}}$	$\frac{692.2^{21}}{645}$	24	12	21	7.0	1.7	2LC0200-8AB2	2LC0200-8AJ2	200
												10	26		6.0	2LC0200-8AB1	2LC0200-8AJ1		190		
690	28000	1200	1650	110	200	690	278	220	130	102	350	$\frac{890_{g7}^{21}}{800_{j6}}$	$\frac{850^{21}}{750}$	24	32	17	15	3.7	2LC0201-0AB2	2LC0201-0AJ2	270
												12	26		11	2LC0201-0AB1	2LC0201-0AJ1		250		
840	45000	1000	1350	140	240	840	340	280	115	105	395	$\frac{1105_{g7}^{21}}{960_{j6}}$	$\frac{1060^{21}}{908}$	30	32	21	46	11	2LC0201-1AB2	2LC0201-1AJ2	530
												16	30		32	2LC0201-1AB1	2LC0201-1AJ1		470		
970	90000	850	1180	160	280	970	390	350	155	137	505	$\frac{1385_{g7}^{21}}{1112_{j6}}$	$\frac{1320^{21}}{1051}$	35	24	31	130	26	2LC0201-2AB2	2LC0201-2AJ2	1050
												16	35		76	2LC0201-2AB1	2LC0201-2AJ1		920		

Configurable variants <sup>1)</sup>

- ØD2 Without finished bore  
With finished bore

Notes

- The hub diameter of the component part is assigned according to the diameter of the finished bore. Where bore diameters overlap, the component with the smaller hub diameter is always selected.
- Weights and mass moments of inertia apply to cast iron version with maximum bore.
- From size 500, the bores D1 and D2 are each provided with a recess of D = +1 mm halfway along the hub.  $V \approx 1/3 NL$ .
- Notice: The application factor FB in the coupling selection Page 12/5 section must be noted.

Ordering example

- ELPEX EFG coupling, size 430, steel version
- Bore ØD1 = 100H7 mm with keyway to DIN 6885 and set screw, flange to SAE J620d size 21 with DFA = 673.5g7 mm
- Coupling balanced G6.3 in accordance with the half parallel key standard.

Article no.: 2LC0200-6AJ29-0AA0-ZM1N+W02

<sup>1)</sup> To identify complete item numbers specifying the available finish boring options and – if necessary – further order options, please use our configurators on [flender.com](http://flender.com).  
<sup>2)</sup> The upper line for the flange connection dimensions complies with standard SAE J620d or DIN 6288.  
 ↗ For online configuration on [flender.com](http://flender.com), click on the item no.

# TYPES EFGS

with fail-safe device

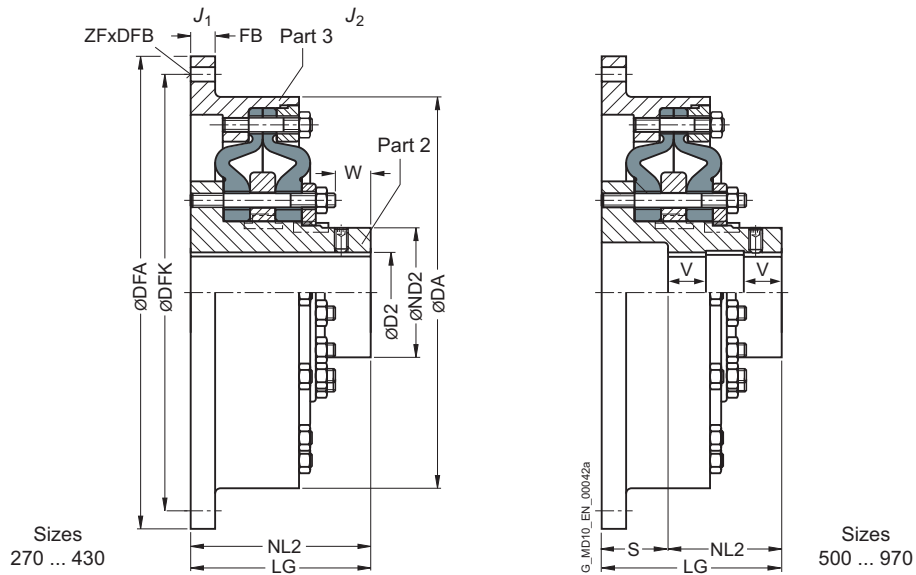

12

Size	Rated torque $T_{KN}$ Nm	Maximum speed		Dimensions in mm										Mass moment of inertia		Article no. <sup>1)</sup>		Weight $m$ kg			
		Type Cast iron	Steel	D2 Keyway DIN 6885 min.   max.	DA	ND2	NL2	S	W	LG	Flange connection dimensions <sup>2)</sup>					$J_1$ kgm <sup>2</sup>	$J_2$ kgm <sup>2</sup>		Type	Cast iron	Steel
											DFA	DFK	FB	ZF	DFB						
270	1600	3000	4250	45	70	270	94	155	-	42	155	466.7 <sub>97</sub> <sup>2)</sup>	438.2 <sup>2)</sup>	12	8	13	0.47	0.037	2LC0200-3AC2	2LC0200-3AK2	27
												325 <sub>6</sub>	300		8	14	0.16				
320	2800	2500	3600	55	85	320	115	180	-	48	180	517.5 <sub>97</sub> <sup>2)</sup>	489 <sup>2)</sup>	14	8	13	0.87	0.082	2LC0200-4AC2	2LC0200-4AK2	42
												392 <sub>6</sub>	360		8	18	0.39				
375	4500	2100	3100	65	105	375	143	205	-	62	205	571.5 <sub>97</sub> <sup>2)</sup>	542.9 <sup>2)</sup>	16	6	17	1.5	0.21	2LC0200-5AC2	2LC0200-5AK2	65
												448 <sub>6</sub>	415		8	18	0.78				
430	7100	1900	2650	75	120	430	165	235	-	68	235	673.1 <sub>97</sub> <sup>2)</sup>	641.4 <sup>2)</sup>	20	12	17	3.4	0.37	2LC0200-6AC2	2LC0200-6AK2	100
												515 <sub>6</sub>	475		8	22	1.5				
500	11200	1600	2300	90	150	500	202	160	100	80	260	673.1 <sub>97</sub> <sup>2)</sup>	641.4 <sup>2)</sup>	20	12	17	4.0	0.85	2LC0200-7AC2	2LC0200-7AK2	150
												585 <sub>6</sub>	545		10	22	2.7				

### Configurable variants <sup>1)</sup>

- ØD2 Without finished bore  
With finished bore

<sup>1)</sup> To identify complete item numbers specifying the available finish boring options and – if necessary – further order options, please use our configurators on [flender.com](http://flender.com).

<sup>2)</sup> The upper line for the flange connection dimensions complies with standard SAE J620d or DIN 6288.

↗ For online configuration on [flender.com](http://flender.com), click on the item no.

Size	Rated torque $T_{KN}$ Nm	Maximum speed		Dimensions in mm										Mass moment of inertia		Article no. <sup>1)</sup>		Weight $m$ kg			
		Cast iron $n_{Kmax}$ rpm	Steel $n_{Kmax}$ rpm	D2 Keyway DIN 6885 min.   max.	DA	ND2	NL2	S	W	LG	Flange connection dimensions <sup>2)</sup>					$J_1$ kgm <sup>2</sup>	$J_2$ kgm <sup>2</sup>		Cast iron	Steel	
											DFA	DFK	FB	ZF	DFB						
590	18000	1350	2000	100	170	590	230	190	120	95	310	733.4 <sub>g7</sub> <sup>2)</sup>	692.2 <sup>2)</sup>	24	12	21	7.0	1.7	2LC0200-8AC2	2LC0200-8AK2	200
												692 <sub>g6</sub>	645		10	26	6.0		2LC0200-8AC1	2LC0200-8AK1	190
690	28000	1200	1650	110	200	690	278	220	130	102	350	890 <sub>g7</sub> <sup>2)</sup>	850 <sup>2)</sup>	24	32	17	15	3.7	2LC0201-0AC2	2LC0201-0AK2	270
												800 <sub>g6</sub>	750		12	26	11		2LC0201-0AC1	2LC0201-0AK1	250
840	45000	1000	1350	140	240	840	340	280	115	105	395	1105 <sub>g7</sub> <sup>2)</sup>	1060 <sup>2)</sup>	30	32	21	46	11	2LC0201-1AC2	2LC0201-1AK2	530
												960 <sub>g6</sub>	908		16	30	32		2LC0201-1AC1	2LC0201-1AK1	470
970	90000	850	1180	160	280	970	390	350	155	137	505	1385 <sub>g7</sub> <sup>2)</sup>	1320 <sup>2)</sup>	35	24	31	130	26	2LC0201-2AC2	2LC0201-2AK2	1050
												1112 <sub>g6</sub>	1051		16	35	76		2LC0201-2AC1	2LC0201-2AK1	920

**Configurable variants <sup>1)</sup>**

- ØD2 Without finished bore  
With finished bore

**Notes**

- The hub diameter of the component part is assigned according to the diameter of the finished bore. Where bore diameters overlap, the component with the smaller hub diameter is always selected.
- Weights and mass moments of inertia apply to cast iron version with maximum bore.
- From size 500, the bores D1 and D2 are each provided with a recess of D = +1 mm halfway along the hub.  $V \approx 1/3 NL$ .
- Notice: The application factor FB in the coupling selection Page 12/5 section must be noted.

**Ordering example**

- ELPEX EFGS coupling, size 430, steel version
- Bore ØD1 = 100H7 mm with keyway to DIN 6885 and set screw, flange to SAE J620d size 21 with DFA = 673.5g7 mm
- Coupling balanced G6.3 in accordance with the half parallel key standard.

Article no.: 2LC0200-6AK29-0AA0-Z M1N+W02

<sup>1)</sup> To identify complete item numbers specifying the available finish boring options and – if necessary – further order options, please use our configurators on [flender.com](http://flender.com).  
<sup>2)</sup> The upper line for the flange connection dimensions complies with standard SAE J620d or DIN 6288.  
 ↗ For online configuration on [flender.com](http://flender.com), click on the item no.

# SPARE AND WEAR PARTS

## Flexible rings

Size	➤ Article no. set of flexible rings for a coupling	Weight kg
270	2LC0200-3XV00-0AA0	1.6
320	2LC0200-4XV00-0AA0	2.6
375	2LC0200-5XV00-0AA0	4.4
430	2LC0200-6XV00-0AA0	6.8
500	2LC0200-7XV00-0AA0	9.4
590	2LC0200-8XV00-0AA0	18
690	2LC0201-0XV00-0AA0	36
840	2LC0201-1XV00-0AA0	68
970	2LC0201-2XV00-0AA0	120

### Note

- The flexible rings are wear parts. The service life depends on the operating conditions.

## Flexible ring screw connection

Size	➤ Article no. set of pins and bolts	
	Type EFG, ENG	EFGS, ENGS
270	2LC0200-3XU00-0AA0	2LC0200-3XW00-0AA0
320	2LC0200-4XU00-0AA0	2LC0200-4XW00-0AA0
375	2LC0200-5XU00-0AA0	2LC0200-5XW00-0AA0
430	2LC0200-6XU00-0AA0	2LC0200-6XW00-0AA0
500	2LC0200-7XU00-0AA0	2LC0200-7XW00-0AA0
590	2LC0200-8XU00-0AA0	2LC0200-8XW00-0AA0
690	2LC0201-0XU00-0AA0	2LC0201-0XW00-0AA0
840	2LC0201-1XU00-0AA0	2LC0201-1XW00-0AA0
970	2LC0201-2XU00-0AA0	2LC0201-2XW00-0AA0





# FLUID COUPLINGS FLUDEX SERIES



<b>General</b>	<b>13/2</b>
Benefits	13/2
Application	13/3
Design and configurations	13/3
Function	13/7
Technical specifications	13/9
Configuration	13/11
Mass moments of inertia	13/17
Technical data for type selection	13/19

<b>FLUDEX coupling as an aid for starting the IEC motors</b>	<b>13/20</b>
Speed $n = 1500$ rpm	13/20
Speed $n = 3000$ rpm	13/24
<b>Type FA0</b>	<b>13/28</b>
<b>Type FAR</b>	<b>13/30</b>
<b>Type FAD</b>	<b>13/32</b>
<b>Type FAE</b>	<b>13/33</b>
<b>Type FAM</b>	<b>13/34</b>
<b>Type FADB</b>	<b>13/35</b>
<b>Type FADS SB</b>	<b>13/36</b>
<b>Type FADS HB</b>	<b>13/37</b>
<b>Oil filling quantities for FA series</b>	<b>13/38</b>
<b>Type FGO</b>	<b>13/40</b>
<b>Type FGD</b>	<b>13/41</b>
<b>Type FGE</b>	<b>13/42</b>
<b>Type FGM</b>	<b>13/43</b>
<b>Oil filling quantities for FG series</b>	<b>13/44</b>
<b>Type FVO</b>	<b>13/46</b>
<b>Type FVD</b>	<b>13/47</b>
<b>Type FVE</b>	<b>13/48</b>
<b>Type FVM</b>	<b>13/49</b>
<b>Oil filling quantities for FV series</b>	<b>13/50</b>
<b>Type FNO</b>	<b>13/52</b>
<b>Type FNA</b>	<b>13/53</b>
<b>Type FND</b>	<b>13/54</b>
<b>Type FNDB</b>	<b>13/56</b>
<b>Type FNDS SB</b>	<b>13/58</b>
<b>Type FNDS HB</b>	<b>13/60</b>
<b>Oil filling quantities for FN series</b>	<b>13/62</b>
<b>Spare and wear parts</b>	<b>13/64</b>



**FLUDEX**  
**FLENDER**

# GENERAL



**Coupling suitable for use in potentially explosive atmospheres.**

**Complies with the current ATEX Directive for:**

**CE**  II 2G Ex h IIB T3 Gb X

 II 2D Ex h IIIC T160°C Db X

 I M2 Ex h Mb X

FLUDEX couplings marked with Ex are constructed with fusible safety plugs 110 °C.

## Benefits

FLUDEX couplings are hydrodynamic fluid couplings which operate on the Föttinger principle. The coupling parts on the input and output sides are not mechanically connected to each other. Output is transmitted via the oil filling which rotates in the coupling and is conducted over radially arranged blades.

FLUDEX couplings limit starting and maximum torque in the drive train and, through the property of rotational slip, serve as an aid to starting the motor, as overload protection in the event of fault and for isolating torsional vibration.

When large masses are started up, the drive train is accelerated only at the torque determined by the coupling characteristic. The starting operation is spread over time, the driven machine started softly and smoothly.

In the case of special operating conditions, such as overload or blocking of the driven machine, the FLUDEX coupling limits the maximum torque load and prevents the inert effect of the rotating motor mass on the drive train. The coupling then acts as a load-holding safety clutch until the drive is shut off by the motor control or coupling monitoring system.

The FLUDEX coupling further acts as a means of decoupling during torsional vibration excitation. Torsional vibration excitation with a frequency of > 5 Hz is virtually absorbed by the coupling.

To compensate for shaft misalignment, the FLUDEX coupling is combined with a displacement coupling e.g. of the N-EUPEX type.

All FLUDEX couplings are designed with radial unset blades and are therefore suitable for rotation in both directions and reversing operation. They can be fitted horizontally, at an angle or vertically. In the case of FLUDEX couplings with a delay chamber it must be ensured, when fitting at an angle or vertically, that the delay chamber is below the working chamber.



## Application

FLUDEX couplings are used in drives for conveyor systems such as belt conveyors, bucket elevators and chain conveyors. In heavy industry FLUDEX couplings are used for applications such as blade wheel drives, crushers, roller presses, mixers, large ventilators, boiler feed pumps, large compressors, centrifuges and auxiliary drives for mills.

Further applications are, for example, pump drives, PTO generator drives, wind power systems and door and gate drives.

In drives with diesel engines, FLUDEX couplings are used on driven machines with a high mass moment of inertia.

## Design and configurations

FLUDEX couplings are constructed of just a few, robust components. Internal components include the hollow shaft or solid shaft (106), to which the blade wheel (105) is connected. The outer housing comprises the cover (102) and the blade wheel housing (101). The joint is constructed as a bolted flange joint and sealed with an O ring. The outer housing and the shaft or hollow shaft have double bearing support and are sealed off to the outside with radial shaft seals. The coupling is provided with two filler plugs (153) with integral overflow protection and with one or two fusible safety plugs (103) in the coupling housing for protection against overheating. The fusible safety plug or a screw plug fitted in the same position also serves as a fluid drain plug and with the aid of a scale marking on the housing can be used as a level indicator.

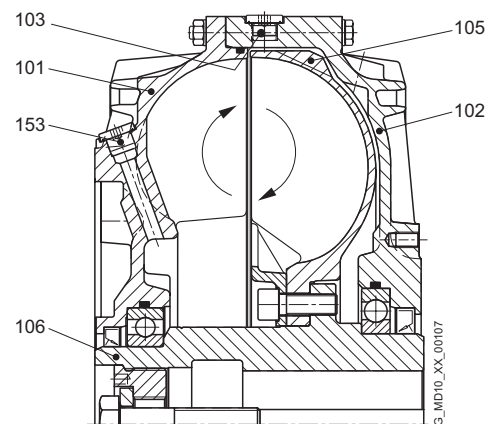

## Materials

- Blade wheel and housing:  
Cast aluminum AlSi10Mg or AlSi9Mg
- Shaft and hollow shaft:  
Steel with a yield point higher than 400 N/mm<sup>2</sup>
- Static seals and radial shaft seals:  
Perbunan NBR or Viton FPM
- Add-on parts:  
Grey cast iron EN-GJL-250, spheroidal graphite cast iron EN-GJS-400 or steel

## Fusible safety plugs

If a FLUDEX coupling is operated with an impermissibly high slip for a prolonged period, the oil filling and the coupling housing will overheat. Fusible safety plugs which release the oil filling into the environment upon reaching a preset temperature are therefore fitted in each coupling housing. These protect the coupling from irreparable damage through overheating or overpressure and disconnect the drive motor from the driven machine.

# GENERAL

## Thermal equipment

Equipment	Suitability for coupling continuous operating temperatures	Fusible safety plug	Sealing materials
Standard	up to 85 °C	110 °C	NBR FPM
	up to 85 °C	140 °C	NBR FPM
	up to 110 °C	160 °C	FPM
ATEX	up to 85 °C	110 °C ex	NBR FPM
With thermal switch <sup>1)</sup>	up to 85 °C	140 °C + thermal switch 110 °C	NBR FPM
	up to 110 °C	160 °C + thermal switch 140 °C	FPM
With transmitter <sup>1)</sup>	up to 85 °C	160 °C + EOC transmitter (125 °C)	NBR
	up to 110 °C		FPM

## Thermal switching equipment

By adding thermal switching equipment leakage and loss of the hydraulic fluid as well as a risk to and contamination of the environment in the event that the coupling overheats can be avoided.

The thermal switching equipment does not work if a machine side is blocked and the coupling housing is connected to this side. If the coupling is stationary, the switching pin cannot actuate the switching equipment.

The thermal switching equipment comprises the thermal switch and the switchgear.

The switchgear comprises a limit switch with a make-and-break contact and a swiveling cam. Limit switch and cam are mounted on a common base plate. The thermal switch is screwed into the housing in place of a screw plug. The fusible safety plug (with a higher response temperature) remains in the coupling for additional safety.

If the set temperature is exceeded, the switching pin is released from the fusible element, emerges 10 mm from the housing and actuates the switchgear while the coupling is rotating. The switchgear can cut out the drive motor and/or trigger an optical or acoustic alarm signal. The housing of the coupling remains closed and no operating fluid will escape.

Continuous operating temperature	Thermal switch	Fusible safety plug
< 85 °C	110 °C	140 °C
> 85 ° ... 110 °C	140 °C	160 °C

13

<sup>1)</sup> Not available for size 222.

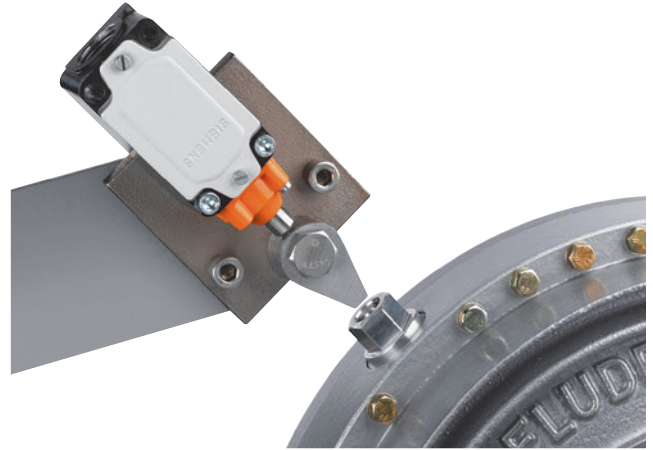
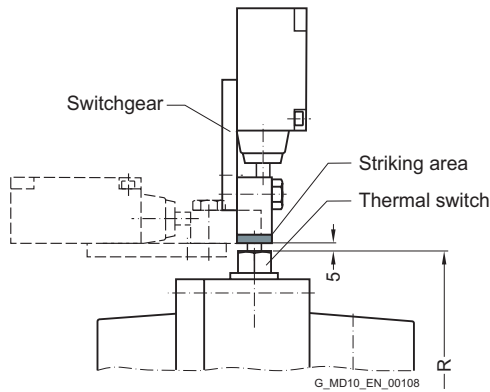

	Coupling size												
	297	342	370	395	425	450	490	516	565	590	655	755	887
Perm. speed in rpm	2500	2240	2100	2000	1900	1800	1650	1600	1500	1450	1250	1100	1000
Radius of travel R in mm	188	215	226	239	251	271	292	307	330	346	383	435	507

From coupling size 297, the thermal switching equipment can be used up to a peripheral speed of 50 m/s. At higher speeds, an EOC system should be provided.

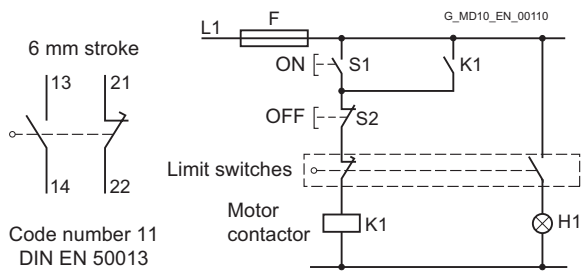

Snap-action switching contact

Wiring proposition

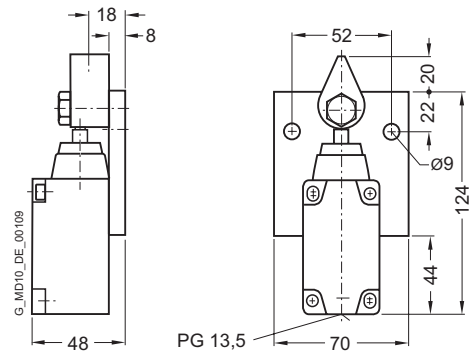

Switchgear: FFA:000000652020

# GENERAL

## EOC system

On the EOC system the temperature-dependent magnitude of the magnetic field of the EOC transmitter is measured and used for a switching pulse. The transmitter signal is transmitted via the fixed sensor to the evaluation instrument and there compared with the set value. If the signal does not exceed the minimum value or no signal is received, the relay of the evaluation instrument switches over. This can cause a malfunction message to be sent and the motor cut out. The coupling housing remains closed.

The fusible safety plug with a higher response temperature remains in the coupling for additional safety. The response temperature of the EOC system is 125 °C.

### Components of the EOC system

Component	Article No.
EOC transmitter with seal	FFA:000001194899
EOC sensor	FFA:000000361460
Evaluation instrument EWD	FFA:000001205294

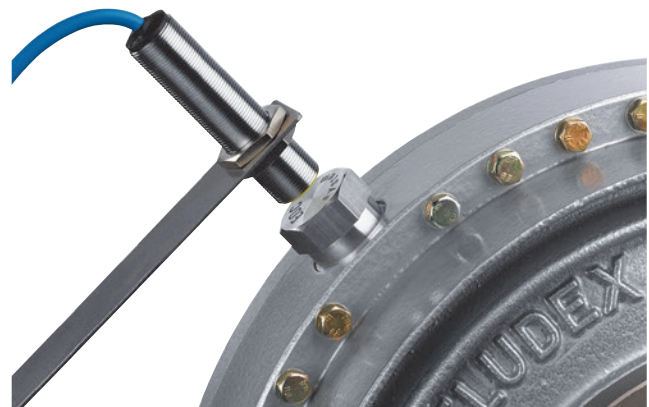
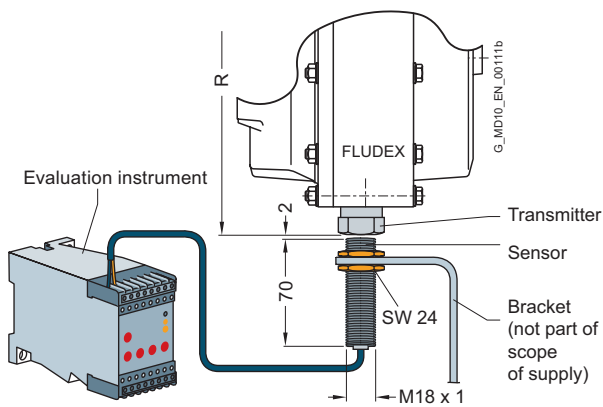

Coupling size	Radius of travel R to the transmitter in mm												
	297	342	370	395	425	450	490	516	565	590	655	755	887
Radius of travel R to the transmitter in mm	188	215	226	239	251	271	292	307	330	346	383	435	507

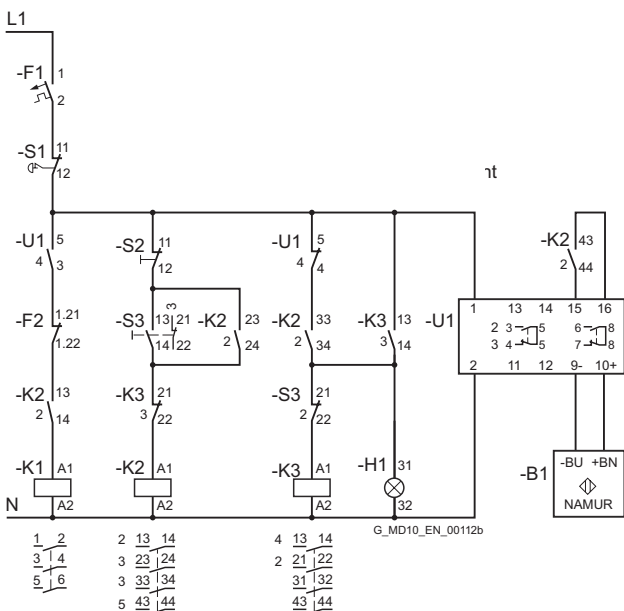

### Wiring proposition

- B1 Sensor
- F1 Fuse
- F2 Motor protection switch
- H1 Malfunction
- K1 Motor protection
- K2 Contactor relay
- K3 Contactor relay
- S1 Emergency stop
- S2 Motor Off
- S3 Motor On
- U1 Evaluation instrument

## Function

### Föttinger principle

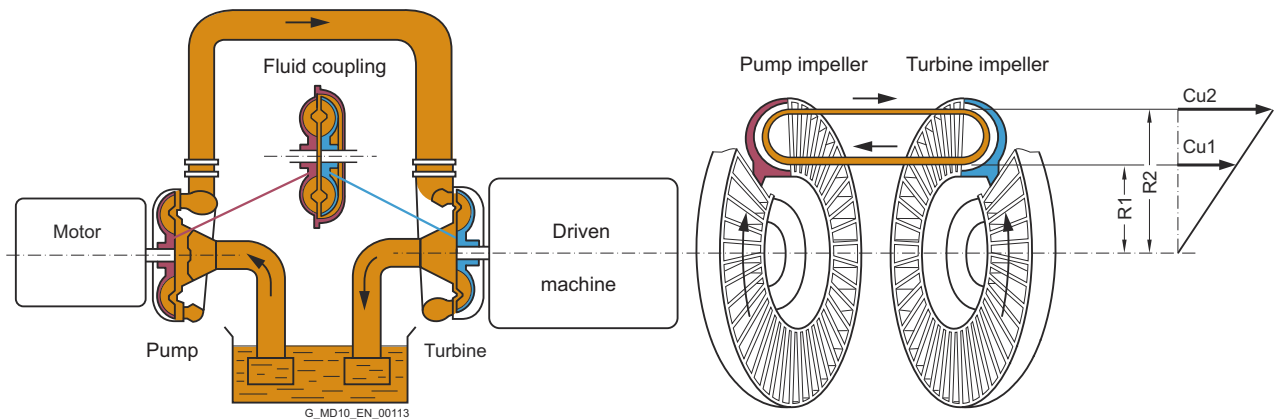

Two opposing, radially bladed impellers are housed in a leakproof housing. The impellers are not mechanically connected to each other. Because of the axially parallel arranged blades, the torque is transmitted independently of the direction of rotation and solely by the oil filling.

Hydrodynamic couplings have the characteristic properties of fluid flow engines. The transmissible torque depends on the density and quantity of the operating fluid and increases as the square of the drive speed and the fifth power of the profile diameter denoting the coupling size. In the driven pump impeller, mechanical energy is converted into kinetic flow energy of the operating fluid. In the turbine impeller, which is connected to the output side, flow energy is converted back to mechanical energy.

To generate the operating fluid circulation necessary for torque transmission, a difference in speed is necessary between the pump and turbine impellers. A centrifugal force pressure field is set up that is greater in the faster rotating pump impeller than in the turbine impeller. The difference in speed, usually termed "slip", at the continuous operating point of the coupling is between 2 % and 6 %, depending on application and coupling size. Immediately after drive motor start-up slip is 100 %, i.e. the pump impeller is driven at the speed of the motor, but the turbine impeller remains stationary.

Slip multiplied by the transmitted power represents the power loss of the coupling, which is converted into heat inside the oil filling. The amount of heat generated must be released into the environment via the coupling housing to prevent an impermissible temperature rise. The rated coupling output is mainly determined by the power loss which can be dissipated at a still acceptable operating temperature or a reasonable set slip limit. This distinguishes the FLUDEX coupling from all positively acting coupling assembly options for which the rated coupling torque is the defining characteristic.

Depending on the FLUDEX coupling series, drive is via the inner rotor (shaft/hollow shaft with rigidly connected blade wheel) or via the bladed housing impeller (blade wheel housing). The driving impeller is the pump impeller, and the driven impeller is the turbine impeller.

A low-viscosity mineral oil VG 22/VG 32, which also serves to lubricate the bearings, is used as fluid. In special types water, a water emulsion or low-flammability fluid may be used as a non-combustible fluid.

# GENERAL

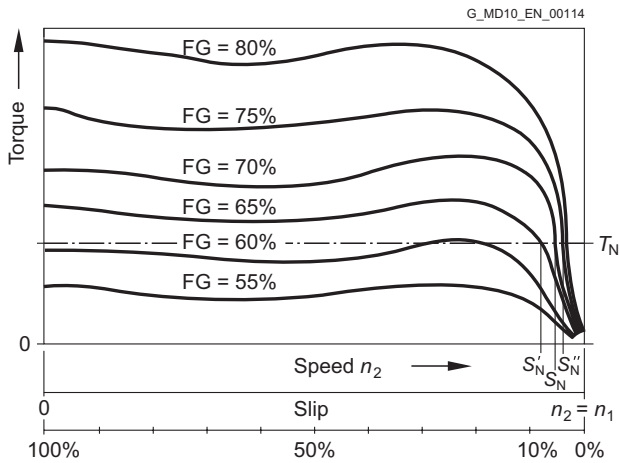

Slip-torque characteristics for different filling levels FG

The torque characteristic depends on the oil filling quantity FG in the coupling. This enables the transmissible torque on starting up to be set via the filling level. With a higher filling level the starting torque increases, while the operating slip and thus the coupling temperature rise decreases.

Conversely, with a lower filling level the starting torque decreases, the coupling becomes softer, while slip and coupling temperature rise.

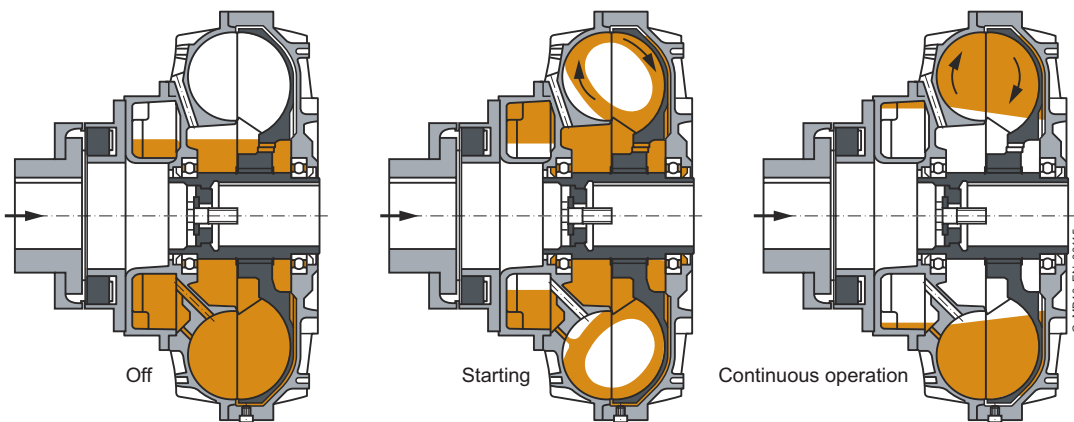

Operation of the delay chamber

Starting torque can be reduced without increasing continuous operating slip by using a type of coupling with a delay chamber. On these couplings part of the oil filling is initially stored inactively in the delay chamber. The starting torque is considerably reduced because of the thus reduced starting filling in the working chamber of the coupling. The filling in the delay chamber runs very slowly,

mostly only at the finish of the starting operation, from the delay chamber into the working chamber, causing the active filling in it to rise gradually and the continuous operating slip to reach a value corresponding to the whole filling.

## Technical specifications

### Balancing FLUDEX couplings

In deviation from the balancing specifications in **Chapter E**, all FLUDEX couplings complying with DIN ISO 21940 are balanced to balancing quality G6.3 for 1800 rpm. For operating speeds higher than 1800 rpm micro-balancing, based on operating speed, can be requested.

Balancing is a two-level balancing with the specified oil quantity or a 75 % filling.

FLUDEX couplings are balanced in accordance with the half parallel key standard. Other balancing standards must be specified in the order.

Add-on couplings are subject to the standards as set out in **Chapter E**.

### Oil filling

FLUDEX couplings can be delivered with or without oil filling.

- Delivery without oil filling
- Delivery with oil filling
- Delivery without oil filling but with oil filling quantity specification in liters

### Hollow shafts of the FA, FG and FV series

Variant of FLUDEX hollow shafts only with finished bore.

### Operating temperature range of FLUDEX couplings

FLUDEX couplings are suitable for ambient temperatures of between -40 °C and +40 °C.

For use at temperatures below -15 °C, FLUDEX couplings are exclusively delivered with NBR seals (Perbunan).

For use at temperatures below -20 °C, FLUDEX couplings are generally delivered without oil filling.

To select the operating oil for low temperatures, ensure that the pour point of the oil is sufficiently low and that it is compatible with the sealing elements.

The temperature limits of the N-EUPEX add-on coupling are shown in part 7 of this catalogue.

If other displacement couplings are combined with a FLUDEX coupling, their respective temperature limits must be taken into account.

# GENERAL

## Operating conditions for FLUDEX couplings in potentially explosive atmospheres

The coupling with fusible safety plugs with identity marking Ⓢ T3 is suitable for the operating conditions set out in the ATEX Directive 2014/34/EU:

### Equipment group II (above-ground applications)

Temperature class T3 of categories 2 and 3 for environments where there are potentially explosive gas, vapors, mist and air mixtures and for environments where dust can form potentially explosive atmospheres.

### Equipment group I (below-ground applications) of category M2

Ⓢ If used in potentially explosive environments under ground, aluminum couplings must be provided with a robust enclosure to preclude the risk of ignition caused by e.g. friction, impact or friction sparks. The deposit of heavy-metal oxides (rust) on the coupling housing must be prevented by the enclosure or other suitable means.

Ⓢ FLUDEX couplings can be delivered with fitted brake disk or V-belt pulley. Designing the belt drive or the brake disk to conform with the guidelines is the responsibility of the sub-assembly supplier. It should be noted that there is a risk from, amongst other things, electrostatic charges and hot surfaces. Under BGR 132 (regulations of German Institute for Occupational Safety) the use of V-belts in conjunction with IIC gases is not permitted.

## Axial retention

Axial retention is provided by a set screw or end washer with a retaining screw for shaft ends to DIN 748/1 long with a centering thread to DIN 332/2.

Bore and keyway width tolerances are specified in Chapter A.

Weights specified in the dimension order tables apply to maximum bore diameters without oil filling.



## Configuration

### Selection of FLUDEX coupling

In accordance with the requirements catalog various series, sizes and types of FLUDEX coupling are available. The FLUDEX coupling series is characterized by various flow chamber configurations, fitted delay chambers or fittings in the flow chamber. The types are determined by the design of the add-on coupling.

This results in different starting factors and characteristics which can be used for the most varied applications. The size is specified by stating the flow outside diameter.

When selecting, the series required for the application, taking into account the starting factor and the characteristic, must be selected.

### Selection of FLUDEX series

Series	Description
FA../FG..	Basic coupling without delay chamber
FV..	Coupling with delay chamber
FN..	Coupling with large delay chamber

FLUDEX couplings, which are to be used solely as an aid to starting the motor under no special conditions, can be selected according to the assignment tables from **Page 13/20** (for  $n = 1500 \text{ min}^{-1}$ ) or from **Page 13/24** (for  $n = 3000 \text{ min}^{-1}$ ).

If special requirements, based on the operating method of the prime mover or driven machine, are made of the coupling or the coupling is to be used in extreme environmental conditions, please give specific details in the enquiry or order. The form "Technical specifications for the selection of type and size" on **Page 13/19** can be used for this purpose.

### Start-up characteristics during the starting process

Depending on the series selected, different starting characteristics arise during starting.

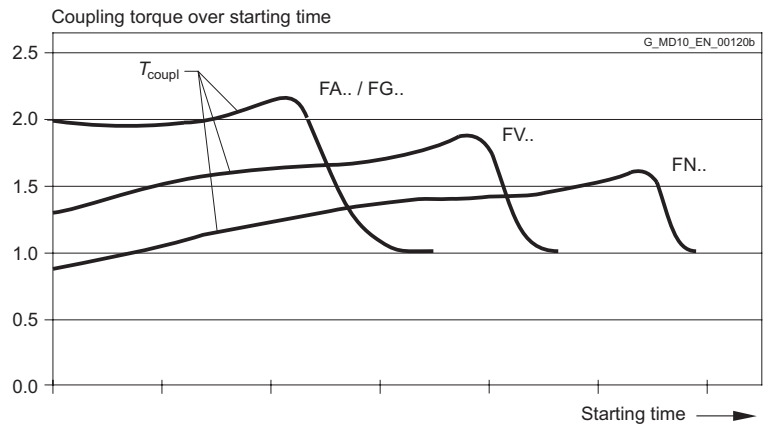
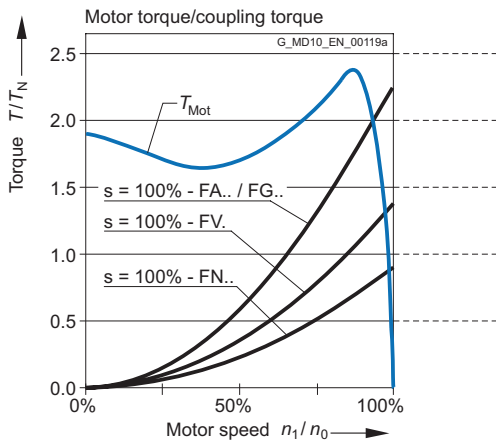

# GENERAL

## FA series – drive via the hollow shaft (impeller drive)

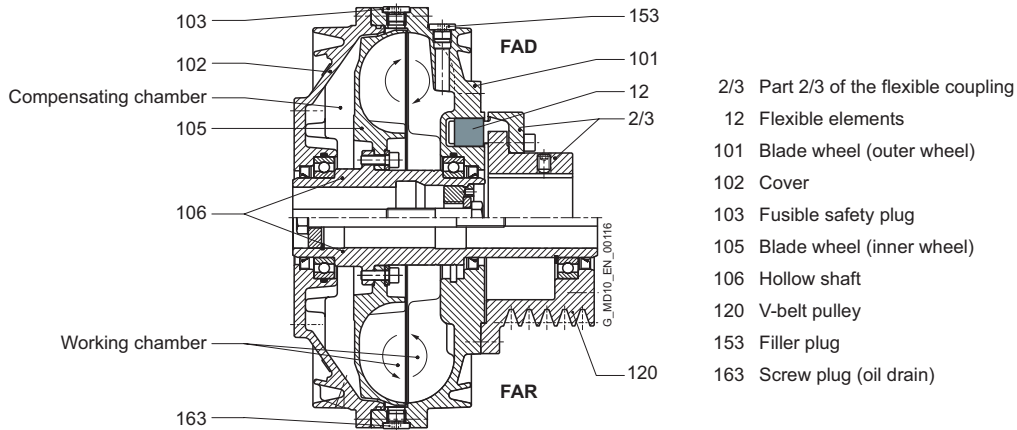

FLUDEX FA series couplings are basic couplings (without delay chamber) which are driven via the hollow shaft (106) with attached blade wheel (105). This enables the advantages of the compensating chamber and the working chamber to be used to best effect. Combinations with brake drums/disks and pulleys can also be easily achieved. When the coupling is started, part of the oil filling in the area of greatest slip is forced into the radially inner chambers and the compensating chamber by the strong rotational flow. This causes the effective oil filling in the working

chamber to be reduced and the desired torque limitation (approx. twice TN) to be achieved during starting. By means of additional fittings the coupling torque at the start of the starting operation can be limited to approx. 1.5 times the rated value. During run-up to speed the compensating chamber again empties into the working chamber, and this helps to reduce slip.

FG and FV series – drive via the housing

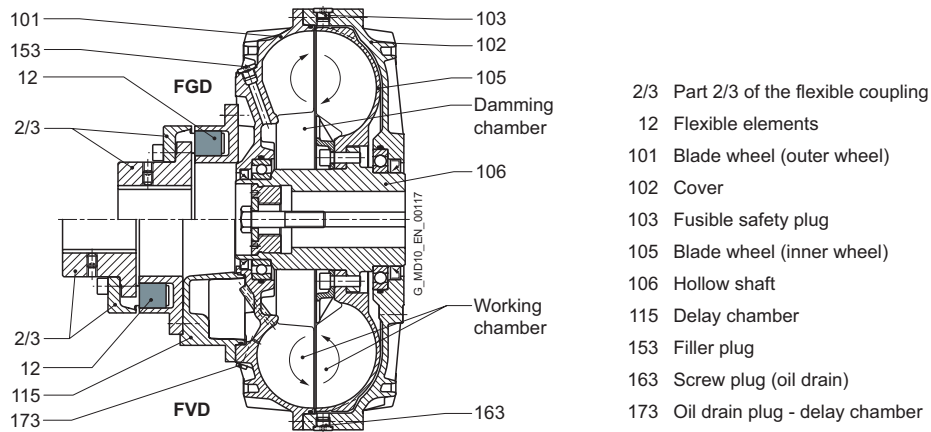

FLUDEX FG and FV series couplings are designed for drive via the coupling housing. In the FV series (coupling with delay chamber), the motor drives the coupling housing, comprising a blade wheel (101) and a cover (102), via the flexible N-EUPEX coupling (part 2/3) and the delay chamber (115). The rotational flow of the coupling filling drives the blade wheel (105) and the hollow shaft (106) on the output side, which is mounted on the gear unit or driven machine shaft. In the FG series (basic coupling), there is no delay chamber, and the flexible coupling is directly flange-mounted on the blade wheel.

When the coupling is started up, part of the oil filling is forced into the damming chamber. This enables the desired torque limitation (approx. twice  $T_N$ ) to be achieved during motor starting. In the FV series the delay chamber also receives part of the oil filling in accordance with the fluid level when the coupling is stationary. During starting the effective oil filling in the working chamber is reduced by the amount of fluid in the delay chamber, thus considerably reducing the starting torque (approx. 1.5 times  $T_N$ ).

From the delay chamber located on the drive side, the oil is fed back time-dependently to the working chamber via small holes and the coupling torque is raised, even if the output is blocked.

This replenishing function enables a drive to be soft-started with a very low starting torque and with an almost load-free motor. At the same time, however, increased load torques can be overcome by the torque increase in the coupling.

The property of the coupling with delay chamber can be used advantageously, for example, to soft-start empty, partly loaded and fully loaded conveyor belts.

FG series couplings are used for normal starting torque limitation, as a starting clutch for isolating vibration and for overload limitation in the event of drive blockage.

# GENERAL

## FN series – drive via the housing

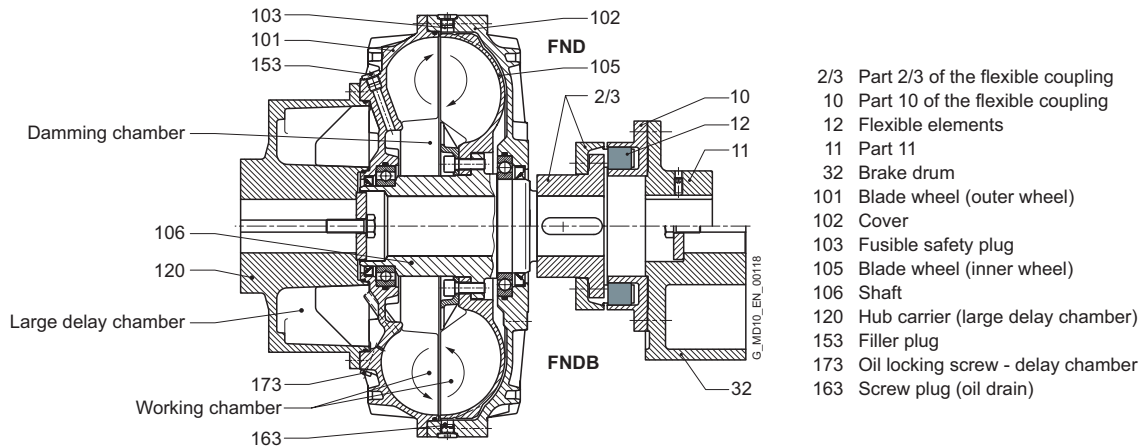

FLUDEX FN series couplings have a larger delay chamber than the FV series. The delay chamber is designed as a hub carrier (120) and is mounted on the motor shaft. The hub carrier is flange-fitted to the housing (101, 102) of the FLUDEX coupling. Output is via the blade wheel (105) and the shaft (106) to the flexible N-EUPEX coupling connecting to the gear unit or driven machine. With types FND, FNDB and FNDS the coupling can be dismantled radially without moving the coupled machines.

The normally stronger motor shaft bears the weight of the hub carrier (cast version) and the main coupling. The gear unit shaft carries only the brake drum or disk and the output-side part of the flexible coupling. At the same time, the principle of the drive-side delay chamber with the capacity for increasing torque time-dependently is retained. FN couplings have the same fields of application as FV couplings. However, they offer special advantages in the brake disk design because of the weight distribution.

Because of the larger delay chamber, FN couplings enable even softer starting than FV couplings. Torque limitation during motor starting is approx. 1.3 times  $T_N$ . A further advantage of types FNDB and FNDS is the favorable weight distribution.

**Selection of FLUDEX type**

Listed in the catalog are FLUDEX couplings with pulley, brake drum, brake disk and flexible N-EUPEX coupling.

Further types, e.g. in combination with a torsionally rigid steel membrane coupling of the ARPEX series or a highly flexible coupling of the ELPEX or ELPEX-S series, are available.

Series	Description	Type	Add-on coupling	Characteristic feature
FA	<ul style="list-style-type: none"> <li>without delay chamber</li> <li>impeller-driven</li> <li>Starting torque: <math>T_{max} = 2.0 \cdot T_{eff}</math></li> <li>Starting aid for standard motors and torsional vibration isolation</li> </ul>	FAO	<b>Without</b>	<ul style="list-style-type: none"> <li>Basic coupling with connecting flange</li> </ul>
		FAR	Without	<ul style="list-style-type: none"> <li>with attached pulley</li> </ul>
		FAD	N-EUPEX D	<ul style="list-style-type: none"> <li>enables change of flexible elements without axial displacement of the machine</li> </ul>
		FAE	N-EUPEX E	<ul style="list-style-type: none"> <li>enables larger bores on the output side</li> </ul>
		FAM	N-EUPEX M	<ul style="list-style-type: none"> <li>enables a short fitting length</li> </ul>
		FADB	N-EUPEX D	<ul style="list-style-type: none"> <li>with brake drum</li> </ul>
		FADS SB	N-EUPEX D	<ul style="list-style-type: none"> <li>with brake disk for stopping brakes</li> <li>enables change of flexible elements without axial displacement of the machine</li> </ul>
		FADS HB	N-EUPEX D	<ul style="list-style-type: none"> <li>with brake disk for blocking brakes</li> <li>enables change of flexible elements without axial displacement of the machine</li> </ul>
FG	<ul style="list-style-type: none"> <li>without delay chamber</li> <li>Housing-driven</li> <li>Starting torque: <math>T_{max} = 2.0 \cdot T_{eff}</math></li> <li>Starting aid for standard motors, for torsional vibration isolation and for overload limitation in the event of drive blockage.</li> </ul>	FGO	<b>Without</b>	<ul style="list-style-type: none"> <li>Basic coupling with connecting flange</li> </ul>
		FGD	N-EUPEX D	<ul style="list-style-type: none"> <li>enables change of flexible elements without axial displacement of the machine</li> </ul>
		FGE	N-EUPEX E	<ul style="list-style-type: none"> <li>enables larger bores on the output side</li> </ul>
		FGM	N-EUPEX M	<ul style="list-style-type: none"> <li>enables a short fitting length</li> </ul>
FV	<ul style="list-style-type: none"> <li>with delay chamber</li> <li>Housing-driven</li> <li>Starting torque: <math>T_{max} = 1.5 \cdot T_{eff}</math></li> <li>Starting aid for motors and soft-starting of conveyor equipment</li> </ul>	FVO	<b>Without</b>	<ul style="list-style-type: none"> <li>Coupling with connecting flange</li> </ul>
		FVD	N-EUPEX D	<ul style="list-style-type: none"> <li>enables change of flexible elements without axial displacement of the machine</li> </ul>
		FVE	N-EUPEX E	<ul style="list-style-type: none"> <li>enables larger bores on the output side</li> </ul>
		FVM	N-EUPEX M	<ul style="list-style-type: none"> <li>enables a short fitting length</li> </ul>
FN	<ul style="list-style-type: none"> <li>with large delay chamber</li> <li>Housing drive via hub carrier</li> <li>Starting torque: <math>T_{max} = 1.3 \cdot T_{eff}</math></li> <li>Starting aid for motors with very unfavorable characteristic and soft-starting of empty and full conveying equipment</li> <li>favorable weight distribution on brake-drum variant</li> </ul>	FNO	<b>Without</b>	<ul style="list-style-type: none"> <li>Coupling with connecting shaft</li> </ul>
		FNA	N-EUPEX A	<ul style="list-style-type: none"> <li>enables a short fitting length</li> <li>enables change of flexible elements without axial displacement of the machine</li> </ul>
		FND	N-EUPEX D	<ul style="list-style-type: none"> <li>enables change of flexible elements without axial displacement of the machine</li> <li>enables fitting and dismantling of the coupling without displacement of the coupled machine</li> </ul>
		FNDB	N-EUPEX D	<ul style="list-style-type: none"> <li>with brake drum</li> <li>enables change of flexible elements without axial displacement of the machine</li> <li>enables fitting and dismantling of the coupling without displacement of the coupled machine</li> </ul>
		FNDS SB	N-EUPEX D	<ul style="list-style-type: none"> <li>with brake disk for stopping brakes</li> <li>enables change of flexible elements without axial displacement of the machine</li> <li>enables fitting and dismantling of the coupling without displacement of the coupled machine</li> </ul>
		FNDS HB	N-EUPEX D	<ul style="list-style-type: none"> <li>with brake disk for blocking brakes</li> <li>enables change of flexible elements without axial displacement of the machine</li> <li>enables fitting and dismantling of the coupling without displacement of the coupled machine</li> </ul>

The maximum shaft misalignments permissible for an N-EUPEX add-on coupling are shown in **catalog FLE 10.2**. For greater shaft misalignments FLUDEX couplings can be combined with cardan shafts or other displacement couplings.

FLUDEX couplings designed specifically for operation with water/water emulsion are available for use in mining applications.

# GENERAL

## Selection of FLUDEX size

The FLUDEX size is determined by the output to be transmitted in comparison with the rated outputs listed in the following tables. No application factors or additional safety factors need be taken into consideration.

The rated outputs stated in the tables normally require the maximum permissible filling (80 % to 85 %) of the coupling and because of operating slip, lead to the coupling heating up by approx. 50 °C relative to the ambient (cooling air) temperature. With lower outputs, coupling heating will be proportionately lower.

If for continuous operation of the coupling an absolute temperature (ambient temperature + coupling heating) of >85 °C is expected, the coupling must be fitted with FPM seals and 160 °C fusible safety plugs.

When selecting the size of a FLUDEX coupling in ATEX design or for operation with water/water emulsion, please note that these versions are normally designed with fusible safety plugs 110 °C and the maximum permitted coupling temperature must be limited to 85 °C.

FA series														FLUDEX size
Speed in rpm														
600	740	890	980	1180	1350	1470	1600	1770	2000	2300	2600	2950	3550	
Rated output $P_N$ in kW														
	1.2	1.6	2.8	4.2	5.5	6.9	8.7	11.7	15	19	24	33		<b>222</b>
1.2	2.3	4	5.5	9	14	18.5	23	29	37	48	60	70	90	<b>297</b>
2.6	4.8	8.7	11.5	18	27	34	40	51	65	82	97	120	145	<b>342</b>
5.7	10	16	21	36	49	61	74	87	105	135	165	180		<b>395</b>
11	21	32	41	65	90	110	127	155	190	230	290	370		<b>450</b>
19	36	60	75	115	154	190	215	260	310	395				<b>516</b>
37	69	109	134	200	260	320	360	435	540					<b>590</b>

FG, FV and FN series														FLUDEX size
Speed in rpm														
600	740	890	980	1180	1350	1470	1600	1770	2000	2300	2600	2950	3550	
Rated output $P_N$ in kW														
4	7.5	12	16	26	38	48	61	85	110	140	170	220	290	<b>370</b>
7.5	15	23	30	48	70	90	115	140	175	220	280	340		<b>425</b>
15	30	45	58	95	140	180	210	245	300	380	480			<b>490</b>
28	55	85	110	180	255	300	350	420	525	660				<b>565</b>
55	110	170	220	350	450	520	600	730	900					<b>655</b>
110	210	330	440	600	760	870	1010	1220						<b>755</b>
240	440	700	810	1130	1440	1660								<b>887</b>
480	880	1400	1600	2000	2350	2500								<b>887D<sup>1)</sup></b>

<sup>1)</sup> D = Multi-pass version on request.

## Mass moments of inertia

FA series										
FLUDEX size	Series		Types						Oil filling quantity	
	FA	FAO	FAD	FAE	FAM	FADB	FADS SB	FADS HB	max.	
	$J_I$	$J_A$	$J_A$	$J_A$	$J_A$	$J_A$	$J_A$	$J_A$	$J_A$	l
	kgm <sup>2</sup>	kgm <sup>2</sup>	kgm <sup>2</sup>	kgm <sup>2</sup>	kgm <sup>2</sup>	kgm <sup>2</sup>	kgm <sup>2</sup>	kgm <sup>2</sup>	kgm <sup>2</sup>	
222	0.014	0.056	0.061	0.061	0.06	0.084	0.287	0.109		1.55
297	0.04	0.173	0.193	0.193	0.193	0.226	0.673	0.246		3.7
342	0.092	0.314	0.356	0.352	0.353	0.469	1.002	0.42		6.6
395	0.203	0.66	0.745	0.73	-	1.03	1.814	1.15		9.5
450	0.404	1.087	1.217	1.217	-	1.497	3.611	1.818		13.4
516	0.896	2.109	2.439	-	-	3.359	5.969	3.238		22.7
590	1.295	3.455	3.785	-	-	6.605	7.315	4.584		33

FAR series					
FLUDEX size	Series		Oil filling quantity		
	$J_I$	$J_A$			
	kgm <sup>2</sup>	kgm <sup>2</sup>	max. l		
222	0.014	2 · SPZ 100 0.062	3 · SPZ 160 0.071	1.55	
297	0.107	5 · SPZ 150 0.202	4 · SPA 190 0.235	5 · SPA 224 0.273	3.7
342	0.095	5 · SPA 180 0.386			6.6
395	5 · SPB = 0,214 7 · SPB = 0,210	5 · SPB 224 0.84	7 · SPB 236 0.96	7 · SPB 280 1.144	9.5
450	0.426	8 · SPB 250 1.467			13.4
516	0.946	10 · SPB 315 3.209			22.7
590	1.375	12 · SPC 315 4.955			33

FG/FV series												
FLUDEX size	Series		Types								Oil filling quantity	
	FG	FV	FGO	FVO	FGD	FVD	FGE	FVE	FGM	FVM	FG	FV
	$J_I$	$J_I$	$J_A$	$J_A$	$J_A$	$J_A$	$J_A$	$J_A$	$J_A$	$J_A$	max.	max.
	kgm <sup>2</sup>	kgm <sup>2</sup>	kgm <sup>2</sup>	kgm <sup>2</sup>	kgm <sup>2</sup>	kgm <sup>2</sup>	kgm <sup>2</sup>	kgm <sup>2</sup>	kgm <sup>2</sup>	kgm <sup>2</sup>	l	l
370	0.191	0.191	0.519	0.551	0.571	0.603	0.571	0.603	0.571	0.603	7.2	8
425	0.342	0.342	0.819	0.876	0.989	1.046	0.974	1.031	0.963	1.02	11	12
490	0.723	0.723	1.992	2.11	2.312	2.43	2.272	2.39	2.264	2.382	17	18.5
565	1.269	1.269	3.216	3.441	3.696	3.921	3.636	3.861	3.616	3.841	25.5	28
655	2.567	2.567	7.287	7.757	8.687	9.157	-	-	-	-	40	44
755	4.856	4.856	12.575	13.291	14.775	15.491	-	-	-	-	59	65
887	11.817	11.817	26.832	28.212	30.102	31.482	-	-	-	-	98	107

### Note

- Mass moments of inertia  $J$  (including the power-transmitting oil filling components) apply to maximum bores

$J_I$  Mass moment of inertia of the inner rotor (hollow shaft [106] + blade wheel [105]) in kgm<sup>2</sup>

$J_A$  Mass moment of inertia of the outer housing (shell [101] + cover [102]) + any parts of the add-on coupling connected to them) in kgm<sup>2</sup>

# GENERAL

FN series										
FLUDEX size	Hub carrier part	Series	Types					Weights		Oil filling quantity max. l
			FN $J_A$ kgm <sup>2</sup>	FNO $J_I$ kgm <sup>2</sup>	FNA $J_I$ kgm <sup>2</sup>	FND $J_I$ kgm <sup>2</sup>	FNDS SB $J_I$ kgm <sup>2</sup>	FNDS HB $J_I$ kgm <sup>2</sup>	Y mm	
370	Standard	0.657	0.237	0.281	0.32	1.18	0.386	197	685	8.2
	Long	0.647						227		
425	Standard	1.107	0.343	0.47	0.491	1.841	0.659	224	970	12.5
	Long	1.102						254		
490	Standard	2.48	0.737	0.954	0.999	3.009	1.285	235	1450	19
	Long	2.474						265		
565	Standard	4.175	1.364	1.715	1.835	5.075	2.081	278	2050	29
	Long	4.251						318		
655	Standard	9.319	2.567	3.587	3.777	6.777	4.701	330	3100	45
	Long	9.523						370		
755	Standard	15.616	4.91	6.878	7.198	12.078	9.689	352	4300	67
	Long	15.95						392		
887	Standard	33.662	11.832	15.132	16.632	24.03	20.428	406	7250	110
	Long	34.462						456		

Type FNDB							
FLUDEX size	Hub carrier part	Brake drum ØDBT · BBT	$J_A$ kgm <sup>2</sup>	$J_I$ kgm <sup>2</sup>	Weights		Oil filling quantity max. l
					Y mm	$F_Y$ N	
370	Standard	Ø315 · 118	0.657	0.64	197	685	8.2
		Ø400 · 150		1.341			
370	Long	Ø315 · 118	0.647	0.64	227	970	12.5
		Ø400 · 150		1.341			
425	Standard	Ø315 · 118	1.107	0.811	224	970	12.5
		Ø400 · 150		1.492			
425	Long	Ø315 · 118	1.102	0.811	254	1450	19
		Ø400 · 150		1.492			
490	Standard	Ø400 · 150	2.48	1.994	235	1450	19
		Ø500 · 190		4.009			
490	Long	Ø400 · 150	2.474	1.994	265	2050	29
		Ø500 · 190		4.009			
565	Standard	Ø400 · 150	4.175	2.835	278	2050	29
		Ø500 · 190		4.775			
565	Long	Ø400 · 150	4.251	2.835	318	3100	45
		Ø500 · 190		4.775			
655	Standard	Ø500 · 190	9.319	6.677	330	3100	45
		Ø630 · 236		11.577			
655	Long	Ø500 · 190	9.523	6.677	370	4300	67
		Ø630 · 236		11.577			
755	Standard	Ø630 · 236	15.616	15.178	352	4300	67
			15.95		392		
887	Standard	Ø710 · 265	33.662	30.832	406	7250	110
			34.462		456		

## Note

- Mass moments of inertia  $J$  (including the power-transmitting oil filling components) apply to maximum bores

$J_I$  Mass moment of inertia of the inner rotor (shaft (106) + blade wheel (105)) + any parts of the add-on coupling connected to them in kgm<sup>2</sup>

$J_A$  Mass moment of inertia of the outer housing (shell (101) + cover (102)) + hub carrier (120) in kgm<sup>2</sup>

Y Centroidal distance of the drive-side coupling masses, measured from the hub end face of the hub carrier.

$F_Y$  Effective weight in mass center including maximum oil filling quantity



## Technical data for type selection

Please complete as far as possible and return to your Flender Sales Office.

### 1. Intended use of coupling

- As starting aid       For overload protection       For torsional vibration isolation

### 2. Data for prime mover

- 2.1  Electric motor       Characteristic enclosed

Power rating  $P_1 =$  ..... kW at speed  $n_1 =$  ..... rpm

- Starting:       Direct       Star delta       Other: .....

Motor shaft:  $\emptyset$  ..... · Length ..... mm

- 2.2  Internal-combustion engine      Number of cylinders: .....

Planned max. power rating: ..... kW at ..... rpm

operating range min. power rating: ..... kW at ..... rpm

- Attachment via shaft  $\emptyset$  ..... · Length ..... mm       Attachment to flywheel SAE ....."

- Motor rigidly       Motor flexibly installed on foundation/base frame

### 3. Data for driven machine

- 3.1 Type of driven machine: .....

- 3.2 Required power rating  $P_2$ : ..... kW at  $n_2 =$  ..... rpm

- 3.3 Mass moment of inertia  $J =$  .....  $\text{kgm}^2$  (based on  $n_2$ )

- 3.4 Operational cycle:       uniform operation       non uniform operation

- 3.4.1. Starting frequency min.:       1 x / day       1 x / week       1 x / month       Continuous operation (min. 2 months without stopping)

Starting frequency max.:       < 3 x in succession      Number in succession: .....

< 5 x / hour      Number per hour: .....

- 3.4.2. Duty cycle per operational cycle:       60 - 100%       ED = ..... %

- 3.4.3. Dimensions of the gear unit/machine shaft on the coupling side  $\emptyset$  ..... · Length ..... mm

### 4. Ambient conditions

- 4.1 Place of installation:       < 1000 m a.s.l.       ..... m a.s.l.

- out of doors       in narrow space       other: .....

- 4.2 Temperature of the ambient air (cooling air):      min. .... °C      max. .... °C

- 4.3  Fitting into guard       bell housing

Holes:       with large (well ventilated)       with small (less well ventilated)

without holes:       with forced ventilation       without forced ventilation

- 4.4 Environment:       normally dusty       extremely dusty       abrasively dusty

aggressive atmosphere: .....

- 4.5 Use in potentially explosive atmospheres

- in conformity with ATEX:      II 2G Ex h IIB T3 Gb X / II 2D Ex h IIIC T160 °C Db X / I M2 Ex h Mb X

- other class: .....

### 5. Arrangement of coupling

- 5.1  horizontal       at an angle (max 20°)       vertical: motor overhead       vertical: motor underneath

- 5.2      between:      and:
- Motor        Driven machine
- Gear unit ( $n_1 =$  ..... rpm)        Gear unit
- Transmission/belt drives        Transmission/belt drives

# FLUDEX COUPLING AS AN AID FOR STARTING THE IEC MOTORS

Speed  $n = 1500 \text{ rpm}$ , Type FAR with fitted V-belt pulley

This assignment offers safety in normal load cases and includes standard types with 140 °C fusible safety plugs, for horizontal fitting and an ambient air temperature from -40 °C to +40 °C.

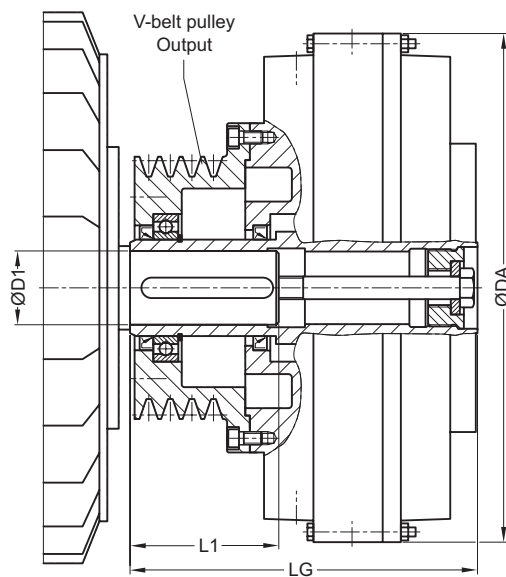

13

Three-phase motor Size	1500 min <sup>-1</sup>		FLUDEX coupling			V-belt pulley			Article no. <sup>1)</sup>	Weight <i>m</i> kg
	$P_M$ kW	D1 · L1 mm	Size	Oil filling l	DA mm	LG mm	Profile, pitch Ø mm	Chamfer number		
80 M	0.55	19 · 40	222	0.9	263	153	SPZ 100	2	1	2LC0900-0AF90-0AA0
	0.75	19 · 40		1			SPZ 100	2	1	
90 S	1.1	24 · 50		1.1			SPZ 100	2	1	2LC0900-0AF90-0AA0
90 L	1.5	24 · 50		1.2			SPZ 100	2	1	2LC0900-0AF90-0AA0
100 L	2.2	28 · 60		1.4			SPZ 100	2	2	2LC0900-0AF90-0AA0
	3	28 · 60		1.5			SPZ 100	2	2	
112 M	4	28 · 60		1.55			SPZ 160	3	2	2LC0900-0AF91-0AA0
132 S	5.5	38 · 80		1.55			SPZ 160	3	2	2LC0900-0AF91-0AA0

### Configurable variants <sup>1)</sup>

- Delivery without oil filling  
 Delivery with oil filling with specification of oil filling quantity in l  
 Delivery without oil filling with oil filling quantity specification in l

<sup>1)</sup> To identify complete item numbers specifying the available finish boring options and – if necessary – further order options, please use our configurators on [flender.com](http://flender.com).

<sup>2)</sup> Flank-open belts required.

↗ For online configuration on [flender.com](http://flender.com), click on the item no.

Three-phase motor			FLUDEX coupling				V-belt pulley			↗ Article no. <sup>1)</sup>	Weight <i>m</i> kg
Size	1500 min <sup>-1</sup>		Size	Oil filling	DA	LG	Profile, pitch Ø	Chamfer number	Recommended no. of belts		
	<i>P<sub>M</sub></i> kW	D1 · L1 mm		l	mm	mm	mm				
132 M	7.5	38 · 80	297	3.2	340	226	SPZ 150	5	3	2LC0900-1AF90-0AA0	
160 M	11	42 · 110		3.5			SPZ 150	5	4	2LC0900-1AF90-0AA0	27
160 L	15	42 · 110		3.7			SPZ 150	5	5	2LC0900-1AF90-0AA0	
180 M	18.5	48 · 110	342	3.7	400	278	SPA 190	4	4	2LC0900-1AF91-0AA0	32
180 L	22	48 · 110		5.5			SPA 180	5	5	2LC0900-2AF90-0AA0	40
200 L	30	55 · 110		6			SPA 180	5	5 <sup>2)</sup>	2LC0900-2AF90-0AA0	
225 S	37	60 · 140	395	7.6	448	325	SPB 224	5	5	2LC0900-3AF90-0AA0	63
225 M	45	60 · 140		7.9			SPB 224	5	5	2LC0900-3AF90-0AA0	
250 M	55	65 · 140		8.4			SPB 224	5	5 <sup>2)</sup>	2LC0900-3AF90-0AA0	
280 S	75	75 · 140	450	10.8	512	410	SPB 250	8	7	2LC0900-4AF90-0AA0	94
280 M	90	75 · 140		11.3			SPB 250	8	8	2LC0900-4AF90-0AA0	
315 S	110	80 · 170		12			SPB 250	8	8 <sup>2)</sup>	2LC0900-4AF90-0AA0	
315 M	132	80 · 170	516	17.7	584	491	SPB 315	10	10	2LC0900-5AF90-0AA0	152
	160	80 · 170		18.6			SPB 315	10	10 <sup>2)</sup>		

**Configurable variants <sup>1)</sup>**

- Delivery without oil filling  
Delivery with oil filling with specification of oil filling quantity in l  
Delivery without oil filling with oil filling quantity specification in l

**Notes**

- The specified coupling weights are effective for maximum bores without oil filling.
- Delivery with oil filling only above -20 °C
- Axial retention is provided by a set screw and/or end washer with a retaining screw for shaft ends to DIN 748/1 long with a centering thread to DIN 332/2.
- For mass moments of inertia, centroidal distance Y and weight FY, see Page 13/18.

**Ordering example**

- Drive with motor 200 L, 30 kW at 1470 rpm with starting clutch and pulley
- FLUDEX FAR 342 coupling, standard type
- Hollow shaft: Bore ØD1 = 55H7 with keyway to DIN 6885/1 and retaining screw, with pulley 5xSPA Ø180.

Article no. delivery without oil filling:  
2LC0900-2AF90-0AA0-Z L1D

Article no. delivery with oil filling:  
2LC0900-1AF90-0AA0-Z L1D+F16+Y90  
Plain text to Y90: 6.0 l

Article no. delivery with specification of oil filling quantity:  
2LC0900-1AF90-0AA0-Z L1D+Y90  
Plain text to Y90: 6.0 l

<sup>1)</sup> To identify complete item numbers specifying the available finish boring options and – if necessary – further order options, please use our configurators on [flender.com](http://flender.com).

<sup>2)</sup> Flank-open belts required.

↗ For online configuration on [flender.com](http://flender.com), click on the item no.

# FLUDEX COUPLING AS AN AID FOR STARTING THE IEC MOTORS

Speed  $n = 1500$  rpm, Type FAD with N-EUPEX D add-on coupling

This assignment offers safety in normal load cases and includes standard types with 140 °C fusible safety plugs, for horizontal fitting and an ambient air temperature from -40 °C to +40 °C.

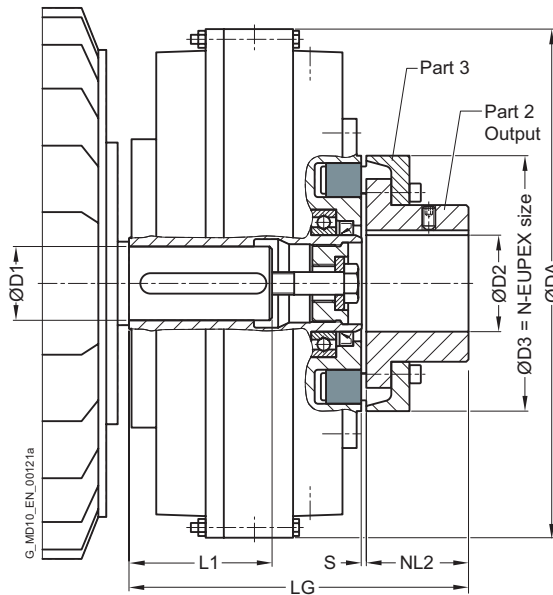

13

Three-phase motor Size	1500 min <sup>-1</sup>		FLUDEX coupling Size				N-EUPEX D add-on coupling			Article no. <sup>1)</sup>	Weight <i>m</i> kg
	$P_M$ kW	D1 · L1 mm	Oil filling l	DA mm	LG mm	NL2 mm	D3 mm	D2 <sup>2)</sup> max. mm			
80 M	0.55	19 · 40	0.9	263	180	40	110	45	2LC0900-0AA9	12	
	0.75	19 · 40	1								
90 S	1.1	24 · 50	1.1								
90 L	1.5	24 · 50	1.2								
	2.2	28 · 60	1.4								
100 L	3	28 · 60	1.5								
	4	28 · 60	1.55								
112 M	4	28 · 60	1.55								
132 S	5.5	38 · 80	1.55	2LC0900-0AA9							

### Configurable variants <sup>1)</sup>

- ØD2 Without finished bore  
With finished bore
- Delivery without oil filling  
Delivery with oil filling with specification of oil filling quantity in l  
Delivery without oil filling with oil filling quantity specification in l

<sup>1)</sup> To identify complete item numbers specifying the available finish boring options and – if necessary – further order options, please use our configurators on [flender.com](http://flender.com).

<sup>2)</sup> Larger bores on the power takeoff side are possible with the FAE type.

↗ For online configuration on [flender.com](http://flender.com), click on the item no.

Three-phase motor			FLUDEX coupling				N-EUPEX D add-on coupling			➤ Article no. <sup>1)</sup>	Weight <i>m</i> kg
Size	1500 min <sup>-1</sup> <i>P<sub>M</sub></i> kW	D1 · L1 mm	Size	Oil filling l	DA mm	LG mm	NL2 mm	D3 mm	D2 <sup>2)</sup> max. mm		
132 M	7.5	38 · 80	297	3.2	340	233	50	125	55	2LC0900-1AA9	24
160 M	11	42 · 110		3.5						2LC0900-1AA9	
160 L	15	42 · 110		3.7						2LC0900-1AA9	
180 M	18.5	48 · 110		3.7						2LC0900-1AA9	
180 L	22	48 · 110	342	5.5	400	271	55	140	60	2LC0900-2AA9	34
200 L	30	55 · 110		6						2LC0900-2AA9	
225 S	37	60 · 140	395	7.6	448	299	90	225	100	2LC0900-3AA9	53
225 M	45	60 · 140		7.9						2LC0900-3AA9	
250 M	55	65 · 140	450	8.4	512	338	100	250	115	2LC0900-3AA9	70
280 S	75	75 · 140		10.8						2LC0900-4AA9	
280 M	90	75 · 140		11.3						2LC0900-4AA9	
315 S	110	80 · 170		12						2LC0900-4AA9	
315 M	132	80 · 170	516	17.7	584	398	125	315	145	2LC0900-5AA9	113
		160		80 · 170							

### Configurable variants <sup>1)</sup>

- ØD2 Without finished bore  
With finished bore
- Delivery without oil filling  
Delivery with oil filling with specification of oil filling quantity in l  
Delivery without oil filling with oil filling quantity specification in l

### Notes

- The specified coupling weights are effective for maximum bores without oil filling.
- Delivery with oil filling only above -20 °C
- Axial retention is provided by a set screw and/or end washer with a retaining screw for shaft ends to DIN 748/1 long with a centering thread to DIN 332/2.
- For mass moments of inertia, centroidal distance Y and weight FY, see Page 13/18.

### Ordering example

- Drive with motor 250 M, 55 kW at 1470 rpm with starting clutch for connecting two shafts.
- FLUDEX FAD 395 coupling, standard type
- Hollow shaft: Bore ØD1 = 65H7 with keyway to DIN 6885/1 and retaining screw
- Part 2: Bore ØD2 = 45H7 with keyway to DIN 6885/1 and set screw

Article no. delivery without oil filling:  
2LC0900-3AA99-0AA0-Z L1F+M1A

Article no. delivery with oil filling:  
2LC0900-3AA99-0AA0-Z L1F+M1A+F16+Y90  
Plain text to Y90: 8.4 l

Article no. delivery with specification of oil filling quantity:  
2LC0900-3AA99-0AA0-Z L1F+M1A+Y90  
Plain text to Y90: 8.4 l

<sup>1)</sup> To identify complete item numbers specifying the available finish boring options and – if necessary – further order options, please use our configurators on [flender.com](http://flender.com).

<sup>2)</sup> Larger bores on the power takeoff side are possible with the FAE type.

➤ For online configuration on [flender.com](http://flender.com), click on the item no.

# FLUDEX COUPLING AS AN AID FOR STARTING THE IEC MOTORS

Speed  $n = 3000$  rpm, Type FAR with fitted V-belt pulley

This assignment offers safety in normal load cases and includes standard types with 140 °C fusible safety plugs, for horizontal fitting and an ambient air temperature from -40 °C to +40 °C.

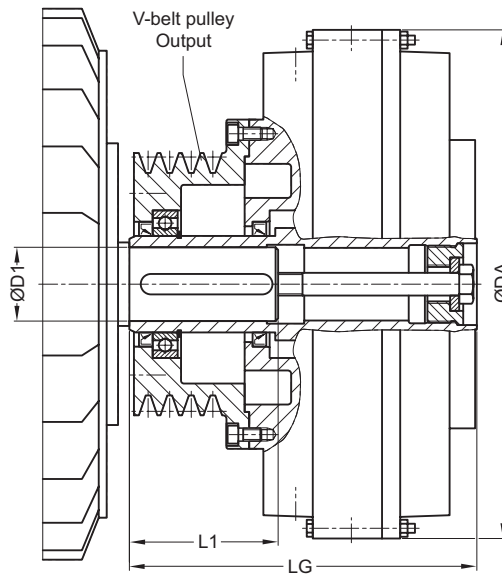

13

Three-phase motor			FLUDEX coupling				V-belt pulley			Article no. <sup>1)</sup>	Weight <i>m</i> kg	
Size	3000 min <sup>-1</sup>	D1 · L1	Oil filling	DA	LG	Profile, pitch Ø	Chamfer number	Recommended no. of belts				
	<i>P<sub>M</sub></i> kW	mm	l	mm	mm	mm						
90 S	1.5	24 · 50	0.7	263	153	SPZ 100	2	1	2LC0900-0AF90-0AA0	12		
90 L	2.2	24 · 50	0.8			SPZ 100	2	1				
100 L	3	28 · 60	0.9			SPZ 100	2	1				
112 M	4	28 · 60	1			SPZ 100	2	2				
132 S	5.5	38 · 80	1			SPZ 100	2	2			2LC0900-0AF90-0AA0	
	7.5	38 · 80	1.1			SPZ 160	3	2			2LC0900-0AF91-0AA0	
160 M	11	42 <sup>3)</sup> · 110	1.2			SPZ 160	3	2			2LC0900-0AF91-0AA0	
	15	42 <sup>3)</sup> · 110	1.3			SPZ 160	3	3				
160 L	18.5	42 <sup>3)</sup> · 110	1.4			SPZ 160	3	3			2LC0900-0AF91-0AA0	14

### Configurable variants <sup>1)</sup>

- Delivery without oil filling  
 Delivery with oil filling with specification of oil filling quantity in l  
 Delivery without oil filling with oil filling quantity specification in l

<sup>1)</sup> To identify complete item numbers specifying the available finish boring options and – if necessary – further order options, please use our configurators on [flender.com](http://flender.com).

<sup>2)</sup> Flank-open belts required.

<sup>3)</sup> Version with flat groove as per DIN 6885/3.

➤ For online configuration on [flender.com](http://flender.com), click on the item no.

Three-phase motor			FLUDEX coupling				V-belt pulley			Article no. <sup>1)</sup>	Weight <i>m</i> kg
Size	3000 min <sup>-1</sup>		Size	Oil filling	DA	LG	Profile, pitch Ø	Chamfer number	Recommended no. of belts		
	<i>P<sub>M</sub></i> kW	D1 · L1 mm		l	mm	mm	mm				
180 M	22	48 · 110	297	2.5	340	226	SPZ 150	5	4	2LC0900-1AF90-0AA0	27
200 L	30	55 · 110		2.7			SPZ 150	5	5	2LC0900-1AF90-0AA0	
	37	55 · 110		2.8			SPA 190	4	4	2LC0900-1AF91-0AA0	32
225 M	45	55 · 110		2.9			SPA 224	5	4	2LC0900-1AF92-0AA0	35
250 M	55	60 <sup>3)</sup> · 140		3.1			SPA 224	5	5	2LC0900-1AF92-0AA0	
280 S	75	65 · 140	5.3	SPB 236	7	5	2LC0900-3AF91-0AA0	70			
280 M	90	65 · 140	5.6	SPB 236	7	6	2LC0900-3AF91-0AA0				
315 S	110	65 · 140	5.9	SPB 236	7	7	2LC0900-3AF91-0AA0				
315 M	132	65 · 140	6.2	SPB 236	7	7 <sup>2)</sup>	2LC0900-3AF91-0AA0				
315 L	160	65 · 140	6.8	SPB 280	7	7 <sup>2)</sup>	2LC0900-3AF92-0AA0		83		

### Configurable variants <sup>1)</sup>

- Delivery without oil filling  
Delivery with oil filling with specification of oil filling quantity in l  
Delivery without oil filling with oil filling quantity specification in l

### Notes

- The specified coupling weights are effective for maximum bores without oil filling.
- Delivery with oil filling only above -20 °C
- Axial retention is provided by a set screw and/or end washer with a retaining screw for shaft ends to DIN 748/1 long with a centering thread to DIN 332/2.
- For mass moments of inertia, centroidal distance Y and weight FY, see Page 13/18.

### Ordering example

- Drive with motor 200 L, 37 kW at 2950 rpm with starting clutch and pulley
- FLUDEX FAR 297 coupling, standard type
- Hollow shaft: Bore ØD1 = 55H7 with keyway to DIN 6885/1 and retaining screw, with pulley 4xSPA Ø190.

Article no. delivery without oil filling:  
2LC0900-1AF91-0AA0-Z L1D+W03+Y95  
Plain text to Y95: G=6.3;n=3000rpm

Article no. delivery with oil filling:  
2LC0900-1AF91-0AA0-Z L1D+F16+W03+Y90+Y95  
Plain text to Y90: 2.8 l  
Plain text to Y95: G=6.3;n=3000rpm

Article no. delivery with specification of oil filling quantity:  
2LC0900-1AF91-0AA0-Z L1D+W03+Y90+Y95  
Plain text to Y90: 2.8 l  
Plain text to Y95: G=6.3;n=3000rpm

<sup>1)</sup> To identify complete item numbers specifying the available finish boring options and – if necessary – further order options, please use our configurators on [flender.com](http://flender.com).

<sup>2)</sup> Flank-open belts required.

<sup>3)</sup> Version with flat groove as per DIN 6885/3.

↗ For online configuration on [flender.com](http://flender.com), click on the item no.

# FLUDEX COUPLING AS AN AID FOR STARTING THE IEC MOTORS

Speed  $n = 3000$  rpm, Type FAD with N-EUPEX D add-on coupling

This assignment offers safety in normal load cases and includes standard types with 140 °C fusible safety plugs, for horizontal fitting and an ambient air temperature from -40 °C to +40 °C.

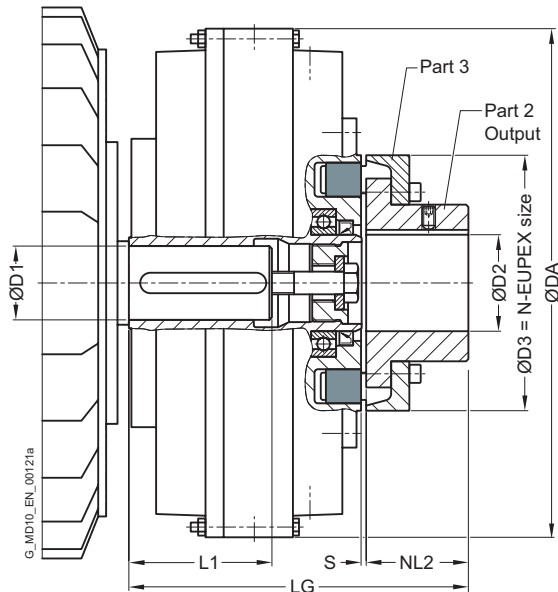

13

Three-phase motor Size	3000 min <sup>-1</sup>		FLUDEX coupling				N-EUPEX D add-on coupling			Article no. <sup>1)</sup>	Weight <i>m</i> kg
	$P_M$ kW	D1 · L1 mm	Size	Oil filling l	DA mm	LG mm	NL2 mm	D3 mm	D2 <sup>2)</sup> max. mm		
90 S	1.5	24 · 50	222	0.7	263	180	40	110	45	2LC0900-0AA9	12
90 L	2.2	24 · 50		0.8							
100 L	3	28 · 60		0.9							
112 M	4	28 · 60		1							
132 S	5.5	38 · 80		1							
	7.5	38 · 80		1.1							
160 M	11	42 <sup>3)</sup> · 110		1.2							
	15	42 <sup>3)</sup> · 110		1.3							
160 L	18.5	42 <sup>3)</sup> · 110	1.4								

### Configurable variants <sup>1)</sup>

- ØD2 Without finished bore  
With finished bore
- Delivery without oil filling  
Delivery with oil filling with specification of oil filling quantity in l  
Delivery without oil filling with oil filling quantity specification in l

<sup>1)</sup> To identify complete item numbers specifying the available finish boring options and – if necessary – further order options, please use our configurators on [flender.com](http://flender.com).

<sup>2)</sup> Larger bores on the power takeoff side are possible with the FAE type.

<sup>3)</sup> Version with flat groove as per DIN 6885/3.

➤ For online configuration on [flender.com](http://flender.com), click on the item no.



Three-phase motor			FLUDEX coupling				N-EUPEX D add-on coupling			Article no. <sup>1)</sup>	Weight <i>m</i> kg
Size	3000 min <sup>-1</sup> <i>P<sub>M</sub></i> kW	D1 · L1 mm	Size	Oil filling l	DA mm	LG mm	NL2 mm	D3 mm	D2 <sup>2)</sup> max. mm		
180 M	22	48 · 110	297	2.5	340	233	50	125	55	2LC0900-1AA9	24
200 L	30	55 · 110		2.7						2LC0900-1AA9	
200 L	37	55 · 110		2.8						2LC0900-1AA9	
225 M	45	55 · 110		2.9						2LC0900-1AA9	
250 M	55	60 <sup>3)</sup> · 140		3.1						2LC0900-1AA9	
280 S	75	65 · 140	395	5.3	448	299	90	225	100	2LC0900-3AA9	53
280 M	90	65 · 140		5.6						2LC0900-3AA9	
315 S	110	65 · 140		5.9						2LC0900-3AA9	
315 M	132	65 · 140		6.2						2LC0900-3AA9	
315 L	160	65 · 140		6.8						2LC0900-3AA9	

**Configurable variants<sup>1)</sup>**

- ØD2 Without finished bore  
With finished bore
- Delivery without oil filling  
Delivery with oil filling with specification of oil filling quantity in l  
Delivery without oil filling with oil filling quantity specification in l

**Notes**

- The specified coupling weights are effective for maximum bores without oil filling.
- Delivery with oil filling only above -20 °C
- Axial retention is provided by a set screw and/or end washer with a retaining screw for shaft ends to DIN 748/1 long with a centering thread to DIN 332/2.
- For mass moments of inertia, centroidal distance Y and weight FY, see Page 13/18.

**Ordering example**

- Drive with motor 280 M, 90 kW at 2950 rpm with starting clutch for connecting two shafts.
- FLUDEX FAD 395 coupling, standard type
- Hollow shaft: Bore ØD1 = 65H7 with keyway to DIN 6885/1 and retaining screw
- Part 2: Bore ØD2 = 60H7 with keyway to DIN 6885/1 and set screw

Article no. delivery without oil filling:  
2LC0900-3AA99-0AA0-Z L1F+M1E+W03+Y95  
Plain text to Y95: G=6.3;n=3000rpm

Article no. delivery with oil filling:  
2LC0900-3AA99-0AA0-Z L1F+M1E+F16+W03+Y90+Y95  
Plain text to Y90: 5.6 l  
Plain text to Y95: G=6.3;n=3000rpm

Article no. delivery with specification of oil filling quantity:  
2LC0900-3AA99-0AA0-Z L1F+M1E+W03+Y90+Y95  
Plain text to Y90: 5.6 l  
Plain text to Y95: G=6.3;n=3000rpm

<sup>1)</sup> To identify complete item numbers specifying the available finish boring options and – if necessary – further order options, please use our configurators on [flender.com](http://flender.com).

<sup>2)</sup> Larger bores on the power takeoff side are possible with the FAE type.

<sup>3)</sup> Version with flat groove as per DIN 6885/3.

↗ For online configuration on [flender.com](http://flender.com), click on the item no.

# TYPE FAO

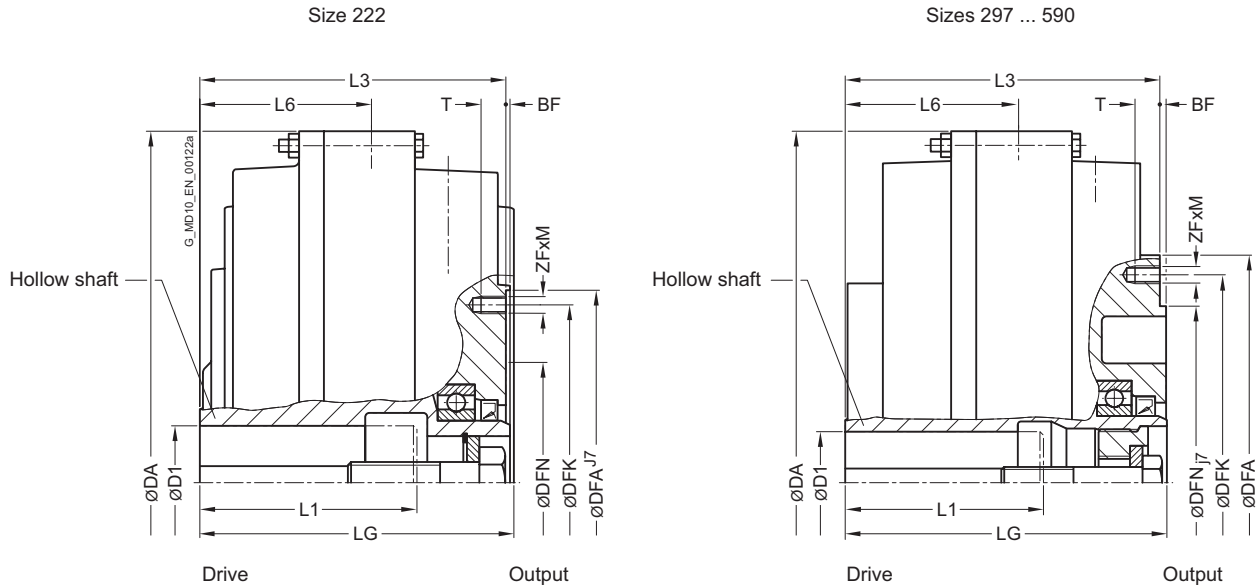

Size	Maximum speed $n_{Kmax}$ rpm	FLUDEX coupling installation dimensions							Flange connection dimensions					Tightening torque for screws in thread ZF x M $T_A$ Nm	Article no. <sup>1)</sup>	Weight $m$ kg		
		D1 Keyway to DIN 6885		L1 max.	DA mm	L3 mm	L6 mm	LG mm	DFN mm	DFA mm	BF mm	DFK mm	ZF · M				T mm	
		min. mm	max. mm															Preferred bore mm
222	3600	>38 <sup>2)</sup>	38 42 <sup>2)</sup>	28	80	263	110	58	112	90	144	2	128	6 · M8	12	18.7	2LC0900-0AG90-0AA0	10
297	3600	>38 >55 <sup>2)</sup>	38 55 60 <sup>2)</sup>	28 42	80 110 110	340	145	83	150	125	195	3	172	6 · M8	12	18.7	2LC0900-1AG90-0AA0	18
342	3600	>55 <sup>2)</sup>	55 60 <sup>2)</sup>	48 + 55	110 120	400	174	101	180	140	230	4	205	8 · M10	15	31	2LC0900-2AG90-0AA0	26
395	3000		65	60 + 65	140	448	200.5	110.5	205	225	290	4	265	8 · M12	18	54	2LC0900-3AG90-0AA0	40

## Configurable variants <sup>1)</sup>

- Delivery without oil filling  
 Delivery with oil filling with specification of oil filling quantity in l  
 Delivery without oil filling with oil filling quantity specification in l

<sup>1)</sup> To identify complete item numbers specifying the available finish boring options and – if necessary – further order options, please use our configurators on [flender.com](http://flender.com).

<sup>2)</sup> Version with flat groove as per DIN 6885/3.

↗ For online configuration on [flender.com](http://flender.com), click on the item no.

Size	Maximum speed $n_{Kmax}$ rpm	FLUDEX coupling installation dimensions								Flange connection dimensions						Tightening torque for screws in thread ZF x M $T_A$ Nm	Article no. <sup>1)</sup>	Weight $m$ kg
		D1 Keyway to DIN 6885			L1 max. mm	DA mm	L3 mm	L6 mm	LG mm	DFN mm	DFA mm	BF mm	DFK mm	ZF · M	T mm			
		min. mm	max. mm	Prefer- red bore mm														
450	3000		75	65 + 75	140	512	228	126	233	250	310	4	285	8 · M12	18	54	2LC0900-4AG90-0AA0	53
		>75	80	170														
516	2300		55		140	584	263	147	270	315	390	5	360	8 · M16	24	135	2LC0900-5AG90-0AA0	84
		>55	90	80	170													
590	2000		75		140	662	298	166	305	315	390	5	360	8 · M16	24	135	2LC0900-6AG90-0AA0	109
		>75	95	170														
		>95	100	210														

### Configurable variants <sup>1)</sup>

- Delivery without oil filling  
Delivery with oil filling with specification of oil filling quantity in l  
Delivery without oil filling with oil filling quantity specification in l

### Notes

- The specified coupling weights are effective for maximum bores without oil filling.
- Delivery with oil filling only above -20 °C
- For mass moments of inertia, centroidal distance Y and weight FY, see Page 13/18.

### Ordering example

- Motor 37 kW,  $P_{eff} = 30$  kW,  $n_1 = 1470$  rpm, maximum output torque:  $T_{max} = 2.0 \cdot T_{eff}$
- FLUDEX FAO coupling size 342
- Hollow shaft: Bore  $\varnothing D1 = 60H7$  mm with keyway to DIN 6885/3 and retaining screw
- Seal set FPM
- Specification of oil filling quantity: 6.0 l (see Page 13/9)

Article no. with 160 °C fuse:

2LC0900-2AG90-0AA0-Z L1E+F08+Y90

Plain text to Y90: 6.0 l

<sup>1)</sup> To identify complete item numbers specifying the available finish boring options and – if necessary – further order options, please use our configurators on [flender.com](http://flender.com).

<sup>2)</sup> Version with flat groove as per DIN 6885/3.

➤ For online configuration on [flender.com](http://flender.com), click on the item no.

# TYPE FAR

with attached v-belt pulley

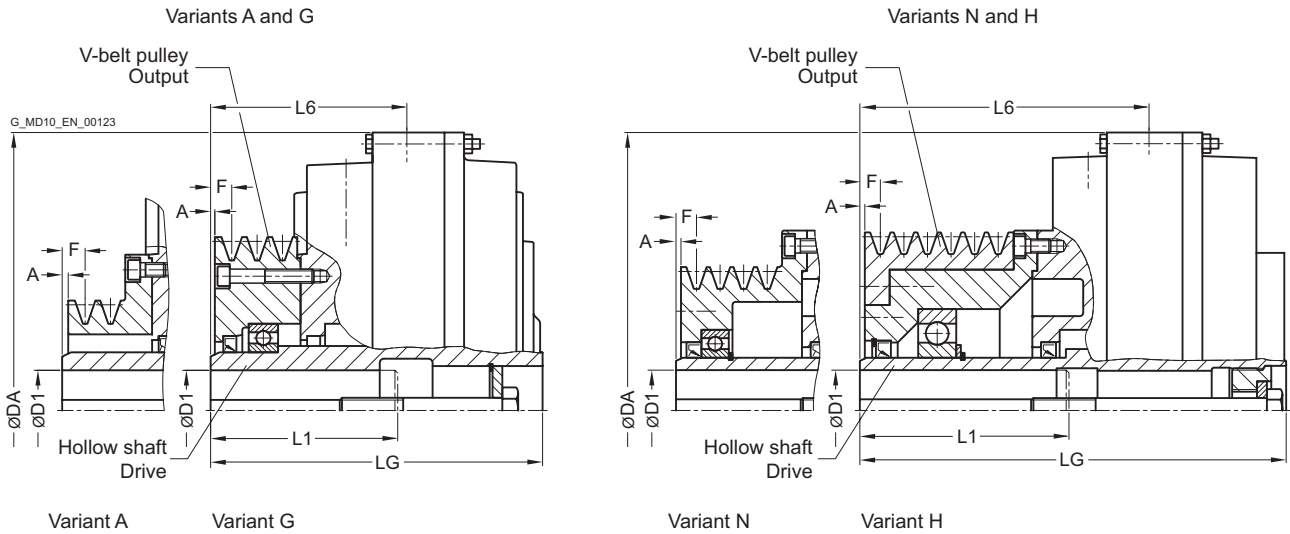

13

Size	Maximum speed $n_{Kmax}$ rpm	FLUDEX coupling							V-belt pulley		Type	Article no. <sup>1)</sup>	Weight $m$ kg			
		D1 Keyway to DIN 6885			L1 max. mm	DA mm	L6 mm	LG mm	Profile, pitch Ø mm	Chamfer number						
		min. mm	max. mm	Prefer- red bore mm										A mm	F mm	
222	3600	28	28	60	263	95	153	SPZ 100	2	1	9	A	2LC0900-0AF90-0AA0	12		
		>28	38	105				SPZ 160	3			G	2LC0900-0AF91-0AA0	14		
		>38 <sup>2)</sup>	42 <sup>2)</sup>	110												
297	3600	38		80	340	143	226	SPZ 150	5	2	10	N	2LC0900-1AF90-0AA0	27		
		>38	55	42				110	SPA 190			4	0	H	2LC0900-1AF91-0AA0	32
		>55 <sup>2)</sup>	59 <sup>2)</sup>	110				SPA 224	5			0	G	2LC0900-1AF92-0AA0	35	
		>59 <sup>2)</sup>	60 <sup>2)</sup>	140				SPA 180	5			4	14	N	2LC0900-2AF90-0AA0	40
395	3000	55		110	448	214.5	325	SPB 224	5	4	16.5	N	2LC0900-3AF90-0AA0	63		
		>55	65	60 + 65				140	SPB 236			7	N	2LC0900-3AF91-0AA0	70	
	2700	55		110	448	253	363.5	SPB 236	7			H	2LC0900-3AF92-0AA0	83		
		>55	75	140				SPB 280	7			H	2LC0900-3AF92-0AA0	83		

### Configurable variants <sup>1)</sup>

- Delivery without oil filling  
 Delivery with oil filling with specification of oil filling quantity in l  
 Delivery without oil filling with oil filling quantity specification in l

<sup>1)</sup> To identify complete item numbers specifying the available finish boring options and – if necessary – further order options, please use our configurators on [flender.com](http://flender.com).

<sup>2)</sup> Version with flat groove as per DIN 6885/3.

↗ For online configuration on [flender.com](http://flender.com), click on the item no.

Size	Maximum speed $n_{Kmax}$ rpm	FLUDEX coupling							V-belt pulley				Article no. <sup>1)</sup>	Weight $m$ kg	
		D1 Keyway to DIN 6885			L1	DA	L6	LG	Profile, pitch Ø	Chamfer number	Type				
		min. mm	max. mm	Prefer- red bore mm	max. mm	mm	mm	mm			A	F			
450	3000		55		110	512	284	410	SPB 250	8	4	16.5	N	2LC0900-4AF90-0AA0	94
		>55	75	65 + 75	140										
		>75	80		170										
516	2300		55		110	584	344	491	SPB 315	10	4	16.5	N	2LC0900-5AF90-0AA0	152
		>55	75		140										
		>75	95		170										
590	2000		55		110	662	476	642	SPC 315	12	4	21	N	2LC0900-6AF90-0AA0	208
		>55	75		140										
		>75	95		170										
		>95	100		210										

### Configurable variants<sup>1)</sup>

- Delivery without oil filling  
Delivery with oil filling with specification of oil filling quantity in l  
Delivery without oil filling with oil filling quantity specification in l

### Notes

- The specified coupling weights are effective for maximum bores without oil filling.
- Delivery with oil filling only above -20 °C

### Ordering example

- Motor 45 kW,  $P_{eff} = 37$  kW,  $n_1 = 1470$  rpm, maximum output torque:  $T_{max} = 2.0 \cdot T_{eff}$ .
- FLUDEX FAR coupling size 395
- Hollow shaft: Bore  $\varnothing D1 = 60H7$  mm with keyway to DIN 6885/1 and retaining screw
- Specification of oil filling quantity: 7.6 l (see Page 13/9)

Article no. with pulley 5xSPB224:  
2LC0900-3AF90-0AA0-Z L1E+Y90  
Plain text to Y90: 7.6 l

Article no. with pulley 7xSPB236:  
2LC0900-3AF91-0AA0-Z L1E+Y90  
Plain text to Y90: 7.6 l

Article no. with 160 °C fuse:  
2LC0900-3AF90-0AA0-Z L1E+Y90+F08  
Plain text to Y90: 7.6 l

<sup>1)</sup> To identify complete item numbers specifying the available finish boring options and – if necessary – further order options, please use our configurators on [flender.com](http://flender.com).

<sup>2)</sup> Version with flat groove as per DIN 6885/3.

➤ For online configuration on [flender.com](http://flender.com), click on the item no.

# TYPE FAD

with N-EUPEX D add-on coupling

Enables change of flexible elements without axial displacement of the shafts if the space "A" is provided.

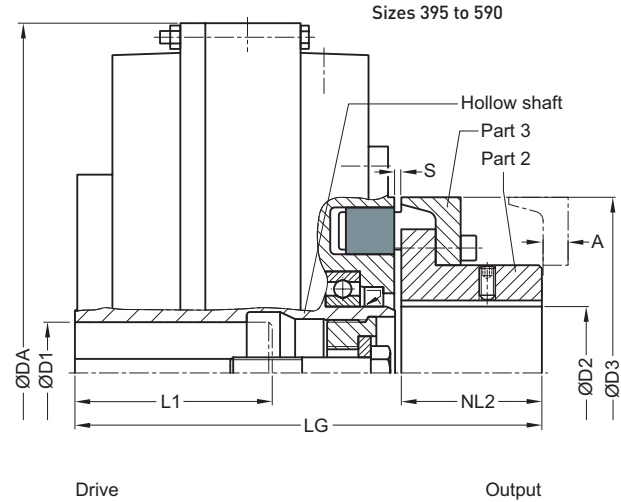
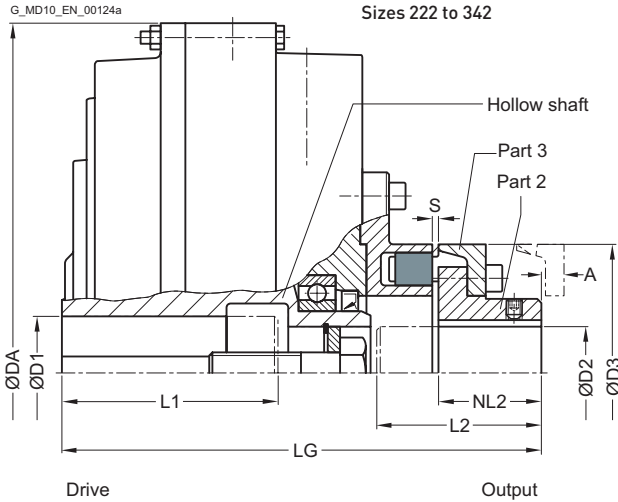

Size	Maximum speed $n_{Kmax}$ rpm	FLUDEX coupling					N-EUPEX D add-on coupling						Article no. <sup>1)</sup>	Weight <i>m</i> kg	
		D1 Keyway to DIN 6885			L1 max. mm	DA mm	LG mm	D2 max. mm	L2 max. mm	NL2 mm	Size D3 mm	S mm			A mm
		min. mm	max. mm	Preferred bore mm											
222	3600	>38 <sup>2)</sup>	38 42 <sup>2)</sup>	28	80	263	180	45	65	40	110	3 <sup>+1</sup> <sub>-1</sub>	13	2LC0900-0AA9	12
297	3600	>38	38	80	110	340	233	55	80	50	125	3 <sup>+1</sup> <sub>-1</sub>	11	2LC0900-1AA9	24
		>55 <sup>2)</sup>	60 <sup>2)</sup>	110											
342	3600	>55 <sup>2)</sup>	55 60 <sup>2)</sup>	48 + 55	110 120	400	271	60	88	55	140	3 <sup>+1</sup> <sub>-1</sub>	16	2LC0900-2AA9	34
395	3000		65	60 + 65	140	448	299	100	90	90	225	4,5 <sup>+1,5</sup> <sub>-1,5</sub>	9	2LC0900-3AA9	53
450	3000	>75	75 80	65 + 75	140 170	512	338	115	100	100	250	6 <sup>+2</sup> <sub>-3</sub>	11	2LC0900-4AA9	70
			55	140	584	398	145	125	125	315	5 <sup>+3</sup> <sub>-2</sub>	0	2LC0900-5AA9	113	
516	2300	>55	90	80											170
590	2000	>75	75 95	140 170	662	433	145	125	125	315	5 <sup>+3</sup> <sub>-2</sub>	0	2LC0900-6AA9	138	
		>95	100	210											

### Configurable variants <sup>1)</sup>

- ØD2 Without finished bore  
With finished bore
- Delivery without oil filling  
Delivery with oil filling with specification of oil filling quantity in l  
Delivery without oil filling with oil filling quantity specification in l

### Notes

- The specified coupling weights are effective for maximum bores without oil filling.
- Delivery with oil filling only above -20 °C

### Ordering example

- Motor 160 kW,  $P_{eff} = 132$  kW,  $n_1 = 1470$  rpm, maximum output torque:  $T_{max} = 2.0 \cdot T_{eff}$ .
- FLUDEX FAD coupling size 516
- Hollow shaft: Bore ØD1= 80H7 mm with keyway to DIN 6885/1 and retaining screw
- Part 2: with finished bore ØD2 = 80H7
- Specification of oil filling quantity: 17.7 l [see Page 13/9]

Article no.: 2LC0900-5AA99-0AA0-Z L1J+M1J+Y90  
Plain text to Y90: 17.7 l

<sup>1)</sup> To identify complete item numbers specifying the available finish boring options and – if necessary – further order options, please use our configurators on [flender.com](http://flender.com).

<sup>2)</sup> Version with flat groove as per DIN 6885/3.

↗ For online configuration on [flender.com](http://flender.com), click on the item no.

# TYPE FAE

with N-EUPEX E add-on coupling

Enables larger bores on the output side.

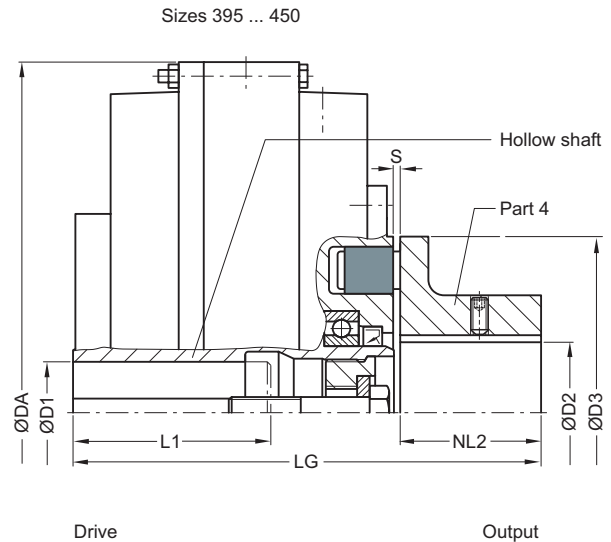
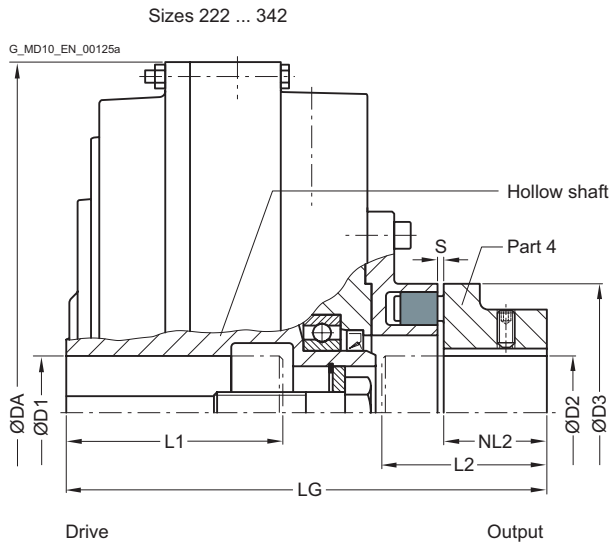

Size	Maximum speed $n_{Kmax}$ rpm	FLUDEX coupling						N-EUPEX E add-on coupling					Article no. <sup>1)</sup>	Weight <i>m</i> kg
		D1 Keyway to DIN 6885			L1 max. mm	DA mm	LG mm	D2 max. mm	L2 max. mm	NL2 mm	Size D3 mm	S mm		
		min. mm	max. mm	Preferred bore mm										
222	3600	38	42 <sup>2)</sup>	28	80	263	180	55	65	40	110	3 <sup>+1</sup> <sub>-1</sub>	2LC0900-0AB9	12
297	3600	38			80	340	233	60	80	50	125	3 <sup>+1</sup> <sub>-1</sub>	2LC0900-1AB9	24
		>38	55 <sup>2)</sup>	42	110									
342	3600	55		48 + 55	110	400	271	65	88	55	140	3 <sup>+1</sup> <sub>-1</sub>	2LC0900-2AB9	34
		>55 <sup>2)</sup>	60 <sup>2)</sup>	120										
395	3000	65		60 + 65	140	448	299	90	90	90	225	4,5 <sup>+1,5</sup> <sub>-1,5</sub>	2LC0900-3AB9	50
450	3000	75		65 + 75	140	512	338	100	100	100	250	6 <sup>+2</sup> <sub>-3</sub>	2LC0900-4AB9	68
		>75	80	170										

### Configurable variants<sup>1)</sup>

- ØD2 Without finished bore  
With finished bore
- Delivery without oil filling  
Delivery with oil filling with specification of oil filling quantity in l  
Delivery without oil filling with oil filling quantity specification in l

### Notes

- The specified coupling weights are effective for maximum bores without oil filling.
- Delivery with oil filling only above -20 °C

### Ordering example

- Motor 45 kW,  $P_{eff} = 42$  kW,  $n_1 = 2950$  rpm
- FLUDEX FAE coupling size 342
- Hollow shaft: Bore ØD1 = 55H7 mm with keyway to DIN 6885/1 and retaining screw
- Part 4: Bore ØD2 = 60H7 mm with keyway to DIN 6885/1 and set screw
- with micro-balancing (high speed)
- with electronic operation monitoring
- seal set NBR
- Delivery without oil filling, no oil filling quantity specification

Article no. with EOC system:

2LC0900-2AB99-0AA0-Z L1D+M1E+F04+F26+W03+Y95

Plain text to Y95: G=6.3;n=3000rpm

<sup>1)</sup> To identify complete item numbers specifying the available finish boring options and – if necessary – further order options, please use our configurators on [flender.com](http://flender.com).

<sup>2)</sup> Version with flat groove as per DIN 6885/3.

↗ For online configuration on [flender.com](http://flender.com), click on the item no.

# TYPE FAM

with N-EUPEX M add-on coupling

Enables a short fitting length.

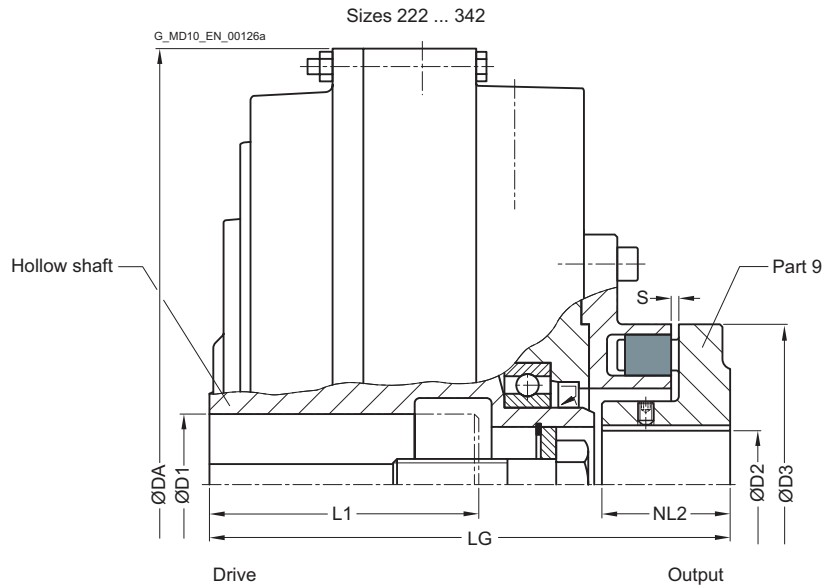

Size	Maximum speed $n_{Kmax}$ rpm	FLUDEX coupling						N-EUPEX M add-on coupling				Article no. <sup>1)</sup>	Weight <i>m</i> kg
		D1 Keyway to DIN 6885			L1 max. mm	DA mm	LG mm	D2 max. mm	NL2 mm	Size D3 mm	S mm		
		min. mm	max. mm	Preferred bore mm									
222	3600		38	28	80	263	150	42	36	110	3 <sup>+1</sup> <sub>-1</sub>	2LC0900-0AH9	12
		>38 <sup>2)</sup>	42 <sup>2)</sup>										
297	3600		38		110	340	203	42	50	125	3 <sup>+1</sup> <sub>-1</sub>	2LC0900-1AH9	24
		>38 <sup>2)</sup>	55 <sup>2)</sup>	42									
342	3600		55	48 + 55	110	400	238	55	55	140	3 <sup>+1</sup> <sub>-1</sub>	2LC0900-2AH9	34
		>55 <sup>2)</sup>	60 <sup>2)</sup>										

### Configurable variants<sup>1)</sup>

- ØD2 Without finished bore  
With finished bore
- Delivery without oil filling  
Delivery with oil filling with specification of oil filling quantity in l  
Delivery without oil filling with oil filling quantity specification in l

### Notes

- The specified coupling weights are effective for maximum bores without oil filling.
- Delivery with oil filling only above -20 °C

<sup>1)</sup> To identify complete item numbers specifying the available finish boring options and – if necessary – further order options, please use our configurators on [flender.com](http://flender.com).

<sup>2)</sup> Version with flat groove as per DIN 6885/3.

↗ For online configuration on [flender.com](http://flender.com), click on the item no.

### Ordering example

- Motor 22 kW,  $P_{eff} = 20$  kW,  $n_1 = 1470$  rpm
- FLUDEX FAM coupling size 342
- Hollow shaft: Bore ØD1 = 40H7 mm with keyway to DIN 6885/1 and retaining screw
- Part 9: Bore ØD2 = 48H7 mm with keyway to DIN 6885/1 and set screw
- Delivery without oil filling, no oil filling quantity specification

Article no. with drive via housing:  
2LC0900-2AH99-0AA0-Z L0W+M1B+F23



# TYPE FADB

with N-EUPEX D add-on coupling and brake drum

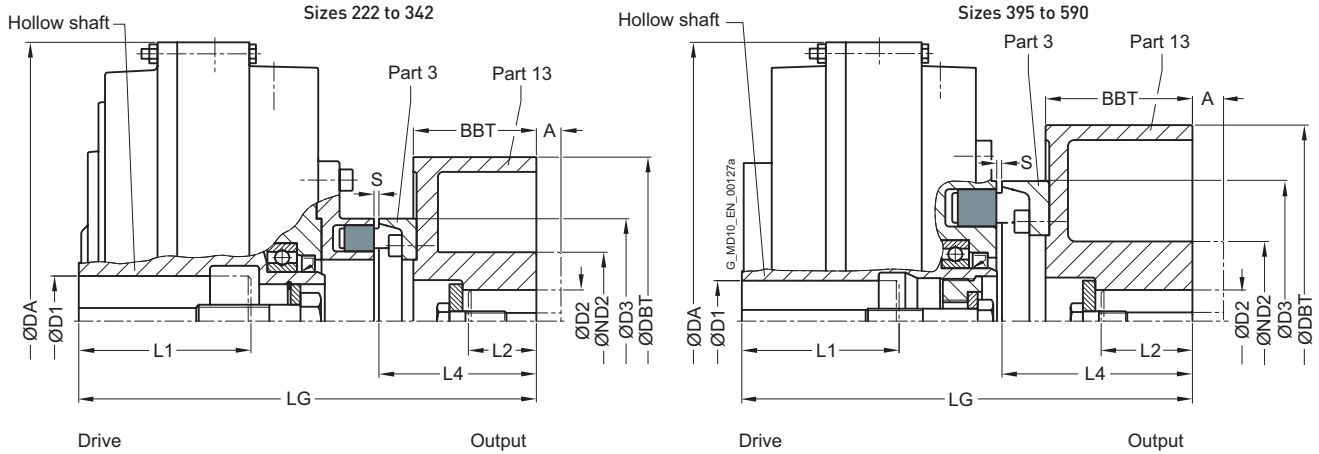

Size	Maximum speed $n_{Kmax}$ rpm	FLUDEX coupling					N-EUPEX D add-on coupling			Brake drum (Part 13)					Article no. <sup>1)</sup>	Weight $m$ kg
		D1 Keyway DIN 6885		L1	DA	LG	Size D3	S	L4	D2	ND2	DBT	BBT	A		
		min. mm	max. mm	max. mm	mm	mm	mm	mm	mm	max. mm	mm	mm	mm	mm		
222	3600	>38 <sup>2)</sup>	38 42 <sup>2)</sup>	80	263	232	110	3 <sup>+1</sup> <sub>-1</sub>	92	42	68	200	75	30	2LC0900-0AC9	17
297	3600	>38	55	80	340	279	125	3 <sup>+1</sup> <sub>-1</sub>	96	55	84	200	75	30	2LC0900-1AC9	29
		>55 <sup>2)</sup>	60 <sup>2)</sup>	110												
342	3600	>55 <sup>2)</sup>	55 60 <sup>2)</sup>	110 120	400	337	140	3 <sup>+1</sup> <sub>-1</sub>	121	60	128 <sup>3)</sup>	250	95	50	2LC0900-2AC9	48
395	3000		65	140	448	362	225	4,5 <sup>+1,5</sup> <sub>-1,5</sub>	153	80	128	315	118	50	2LC0900-3AC9	71
450	3000		75	140	512	395	250	6 <sup>+2</sup> <sub>-3</sub>	157	80	128	315	118	50	2LC0900-4AC9	86
		>75	80	170												
516	2300		55	140	584	466	315	5 <sup>+3</sup> <sub>-2</sub>	193	100	160	400	150	80	2LC0900-5AC9	146
		>55	90	170												
590	1900		75	140	662	540	315	5 <sup>+3</sup> <sub>-2</sub>	232	110	175	500	190	110	2LC0900-6AC9	207
		>75	95	170												
		>95	100	210												

## Configurable variants <sup>1)</sup>

- ØD2 Without finished bore  
With finished bore
- Part 13 Standard brake drum  
Long brake drum
- Delivery without oil filling  
Delivery with oil filling with specification of oil filling quantity in l  
Delivery without oil filling with oil filling quantity specification in l

## Notes

- The specified coupling weights are effective for maximum bores without oil filling, without hub prolongations "A" but with set screw
- L2 denotes the shaft insertion depth.  
In the case of shaft ends deviating from DIN 748/1 long, the insertion depth must be specified in plain text with "Y29"
- Delivery with oil filling only above -20 °C

## Ordering example

- Motor 30 kW,  $P_{eff} = 22$  kW,  $n_1 = 1470$  rpm
- FLUDEX FADB coupling size 342, standard type
- Hollow shaft: Bore ØD1 = 55H7 mm with keyway to DIN 6885/1 and retaining screw
- Brake drum (Part 13): Bore ØD2 = 50H7 mm with keyway to DIN 6885/1 and set screw.
- shaft end insertion depth L2 = 90 mm
- Delivery without oil filling, no oil filling quantity specification

Article no. Part 13 Standard brake drum:

2LC0900-2AC99-0AA0-Z L1D+M1C+Y29  
Plain text to Y29: 90 mm

Article no. Part 13 Long brake drum:

2LC0900-2AC99-0BA0-Z L1D+M1C+Y29  
Plain text to Y29: 90 mm

<sup>2)</sup> Version with flat groove as per DIN 6885/3.

<sup>3)</sup> ND2 = 128 for A = 0  
ND2 = 100 for hub prolongations A = 50

↗ For online configuration on [flender.com](http://flender.com), click on the item no.

<sup>1)</sup> To identify complete item numbers specifying the available finish boring options and – if necessary – further order options, please use our configurators on [flender.com](http://flender.com).

# TYPE FADS SB

with N-EUPEX D add-on coupling and brake disk for stopping brakes

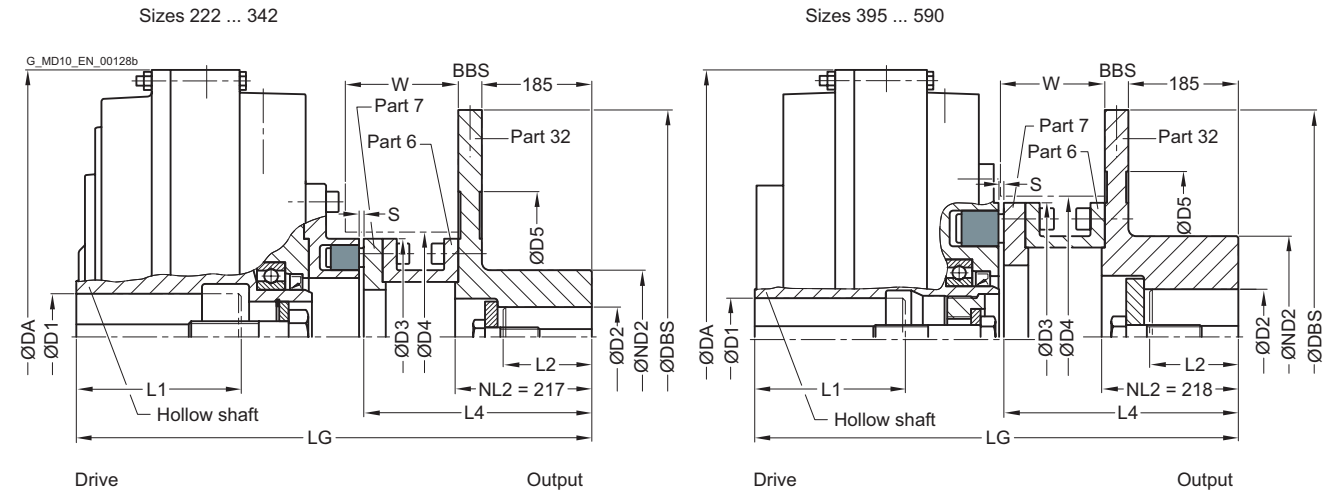

Size	Maximum speed $n_{Kmax}$ rpm	FLUDEX coupling			N-EUPEX D add-on coupling			Brake disk (part 32) <sup>2)</sup>					Space dimensions		Article no. <sup>1)</sup>	Weight m kg		
		D1 Keyway DIN 6885 min. mm	max. mm	L1 max. mm	DA mm	LG mm	Size D3 mm	S mm	L4 mm	D2 max. mm	ND2 mm	DBS mm	BBS mm	D5 mm			D4 mm	W mm
222	3600	38	42 <sup>3)</sup>	80	263	494	110	5 <sup>+1</sup>	352	42	100	315	30	165	115	149	2LC0900-0AD9	35
		>38 <sup>3)</sup>	55	80	340	537	125	5 <sup>+1</sup>	352	60	120	355	30	205	130	155	2LC0900-1AD9	68
297	3600	55	60 <sup>3)</sup>	110	400	570	140	5 <sup>+1</sup>	352	60	120	400	30	250	145	155	2LC0900-2AD9	83
		>55 <sup>3)</sup>	65	120	448	602	225	6 <sup>+1</sup>	391.5	80	150	450	30	300	230	182	2LC0900-3AD9	102
342	3300	75	80	140	512	630.5	250	8 <sup>+1</sup>	390.5	90	160	560	30	370	260	182	2LC0900-4AD9	141
		>75	55	140	584	706.5	315	8 <sup>+1</sup>	430.5	100	160	630	30	440	325	222	2LC0900-5AD9	199
516	2100	90	75	170	662	741.5	315	8 <sup>+1</sup>	430.5	100	160	630	30	440	325	222	2LC0900-6AD9	224
		>55	95	210														
590	2000	75	100	170														
		>75	100	210														

### Configurable variants<sup>1)</sup>

- ØD2 Without finished bore  
With finished bore
- Delivery without oil filling  
Delivery with oil filling with specification of oil filling quantity in l  
Delivery without oil filling with oil filling quantity specification in l

### Notes

- The specified coupling weights are effective for maximum bores without oil filling.
- L2 denotes the shaft insertion depth.  
In the case of shaft ends deviating from DIN 748/1 long, the insertion depth must be specified in plain text with "Y29"
- Delivery with oil filling only above -20 °C

### Ordering example

- Motor 90 kW,  $P_{eff} = 75$  kW,  $n_1 = 1470$  rpm
- FLUDEX FADS SB coupling size 450
- Hollow shaft: Bore ØD1 = 75H7 mm with keyway to DIN 6885/1 and retaining screw
- Brake disk (part 32): Bore ØD2 = 80H7 mm with keyway to DIN 6885/1 and retaining screw
- with preservation suitable for indoor storage
- shaft end insertion depth L2 = 90 mm
- Delivery without oil filling, no oil filling quantity specification

Article no. with preservation 24 months:

2LC0900-4AD99-0AA0-Z L1H+M1J+B28+Y29

Plain text to Y29: L2 = 90 mm

<sup>1)</sup> To identify complete item numbers specifying the available finish boring options and – if necessary – further order options, please use our configurators on [flender.com](http://flender.com).

<sup>2)</sup> Hub shortening possible, clearly specify NL2 size

<sup>3)</sup> Version with flat groove as per DIN 6885/3.

↗ For online configuration on [flender.com](http://flender.com), click on the item no.

# TYPE FADS HB

with N-EUPEX D add-on coupling and brake disk for blocking brakes

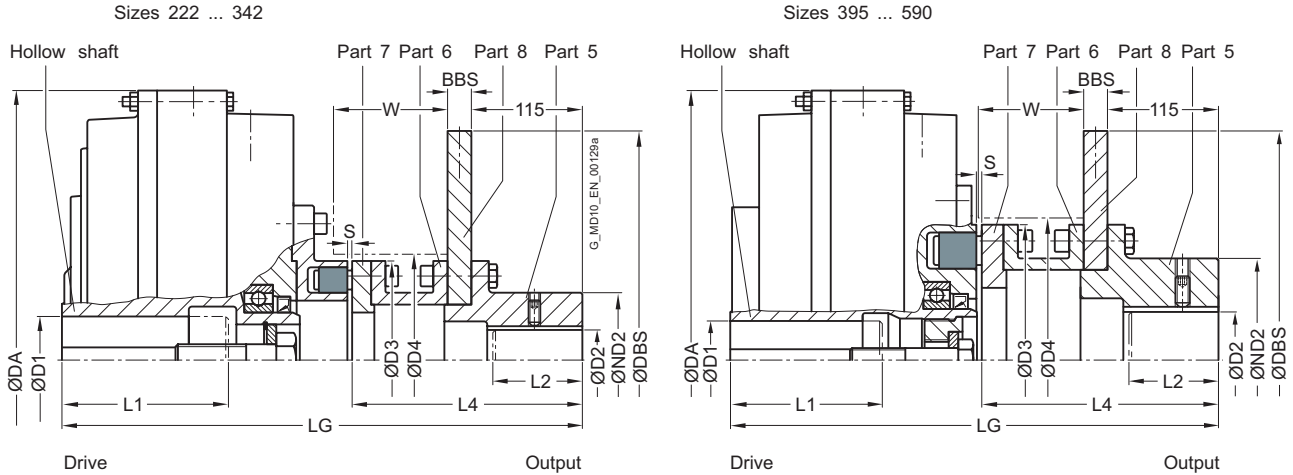

Size	Maximum speed $n_{Kmax}$ rpm	FLUDEX coupling			N-EUPEX D add-on coupling			Brake disk (part 5/8)				Space dimensions		Article no. <sup>1)</sup>	Weight <i>m</i> kg		
		D1 Keyway DIN 6885 min. mm	max. mm	L1 max. mm	DA mm	LG mm	Size D3 mm	S mm	L4 mm	D2 max. mm	ND2 mm	DBS mm	BBS mm			D4 mm	W mm
222	3600	38	42 <sup>2)</sup>	80	263	366.5	110	5 <sup>+1</sup>	224.5	42	70	250	12.5	115	109	2LC0900-0AE9	22
		38	80														
297	3600	>38	55	110	340	409.5	125	5 <sup>+1</sup>	224.5	60	85	250	12.5	130	115	2LC0900-1AE9	33
		>55 <sup>2)</sup>	60 <sup>2)</sup>	110													
342	3600	55	60 <sup>2)</sup>	110	400	442.5	140	5 <sup>+1</sup>	224.5	60	90	250	12.5	145	115	2LC0900-2AE9	45
		>55 <sup>2)</sup>	60 <sup>2)</sup>	120													
395	3000	65	75	140	448	478	225	6 <sup>+1</sup>	267.5	80	150	355	16	230	142	2LC0900-3AE9	80
450	2750	>75	80	170	512	546.5	250	8 <sup>+1</sup>	306.5	90	160	355	16	260	182	2LC0900-4AE9	101
516	2150	55	75	140	584	566.5	315	8 <sup>+1</sup>	290.5	100	160	450	16	325	166	2LC0900-5AE9	154
		>55	90	170													
590	2000	>75	95	170	662	601.5	315	8 <sup>+1</sup>	290.5	100	160	450	16	325	166	2LC0900-6AE9	179
		>95	100	210													

## Configurable variants<sup>1)</sup>

- ØD2 Without finished bore  
With finished bore
- Delivery without oil filling  
Delivery with oil filling with specification of oil filling quantity in l  
Delivery without oil filling with oil filling quantity specification in l

## Notes

- The specified coupling weights are effective for maximum bores without oil filling.
- L2 denotes the shaft insertion depth.  
In the case of shaft ends deviating from DIN 748/1 long, the insertion depth must be specified in plain text with "Y29"
- Delivery with oil filling only above -20 °C

## Ordering example

- Motor 160 kW,  $P_{eff} = 132$  kW,  $n_1 = 2950$  rpm
- FLUDEX FADS HB coupling size 395
- Hollow shaft: Bore ØD1 = 65H7 mm with keyway to DIN 6885/1 and retaining screw
- Part 5: Bore ØD2 = 80H7 mm with keyway to DIN 6885/1 and set screw
- Delivery without oil filling, no oil filling quantity specification

Article no.: 2LC0900-3AE99-0AA0-Z L1F+M1J+W03+Y95  
Plain text to Y95: G=6.3;n=3000rpm

<sup>1)</sup> To identify complete item numbers specifying the available finish boring options and – if necessary – further order options, please use our configurators on [flender.com](http://flender.com).

<sup>2)</sup> Version with flat groove as per DIN 6885/3.

➤ For online configuration on [flender.com](http://flender.com), click on the item no.

# OIL FILLING QUANTITIES FOR FA SERIES

This assignment is valid for a maximum starting torque  $T_{max} = 2.0 \cdot T_{eff}$  and mineral oils with a viscosity of VG 22/VG 32, with drive via the hollow shaft.

If other operating fluids are used, or with drive via the housing or  $T_{max} \neq 2.0 \cdot T_{eff}$ , changed filling quantities must be observed!

Sizes 222, 342, 450 and 590											
$P_{eff}$ kW	Speed in rpm										Size
	600	740	890	980	1180	1470	1770	2300	2950	3550	
Oil filling quantity in l											
0.55	4.3		1.4	1.3	1.1						
0.75	4.7		1.5	1.4	1.2						
1.1	5.1	4.4	1.55	1.55	1.4	1.1					
2.2	6.2	5.2	4.5	4.2	1.55	1.4	1.2				
3	9.5	5.6	4.9	4.6	1.55	1.5	1.3	1			
4	10.2	6.1	5.3	4.9	4.3	1.55	1.4	1.1			
5.5	11	9.4	5.7	5.3	4.6	1.55	1.5	1.2	1		
7.5	12	10.2	6.2	5.8	5	4.3	1.55	1.3	1.1		
11	13.4	11.2	9.7	6.4	5.5	4.7	4.1	1.5	1.2	1	
15	24.8	12.2	10.5	9.8	6	5	4.4	1.55	1.3	1.1	
18	25.9	12.9	11	10.3	6.3	5.3	4.6	3.9	1.4	1.2	
22	27.3	23.3	11.6	10.8	9.4	5.5	4.8	4	1.4	1.25	
30	29.7	25.2	12.7	11.7	10.1	6	5.2	4.3	3.7	1.4	
37	31.5	26.5	23.1	12.4	10.7	9.1	5.5	4.5	3.9	1.5	
45		27.9	24.2	22.6	11.2	9.5	5.8	4.7	4	3.5	
55		29.5	25.5	23.7	11.9	10	8.8	5	4.2	3.7	
75			27.6	25.7	22.3	10.8	9.4	5.4	4.5	3.9	
90			29	26.9	23.4	11.3	9.8	8.1	4.7	4.1	
110				28.3	24.5	12	10.4	8.6	4.9	4.3	
132				29.7	25.7	21.9	10.8	8.9	7.6	4.5	
160					27	22.9	20	9.3	7.8		
180					27.8	23.5	20.6	10	8		
200					28.6	24.2	21.2	10.9	8.2		
225						24.9	21.8	11.5	8.5		
250						25.6	22.3		9.6		
280						26.3	22.9		9.9		
315						27.1	23.6		10.5		
350							24.2				
400							26.4				

Sizes 297, 395 and 516											
$P_{eff}$ kW	Speed in rpm										Size
	600	740	890	980	1180	1470	1770	2300	2950	3550	
	Oil filling quantity in l										
0.55	3.2	2.8									
0.75	3.5	3	2.6								
1.1	3.7	3.3	2.9	2.7							
2.2	7.3	3.7	3.4	3.2	2.8						
3	7.9	6.8	3.7	3.4	3	2.5					
4	8.5	7.3	3.7	3.7	3.2	2.7					
5.5	9.4	7.9	6.8	3.7	3.5	2.9	2.6				
7.5	17	8.5	7.4	6.9	3.7	3.2	2.8	2.4			
11	18.7	16	8.1	7.6	6.6	3.5	3	2.5			
15	20.3	17.3	8.9	8.2	7.1	3.7	3.3	2.7			
18	21.4	18	15.7	8.6	7.4	3.7	3.4	2.8	2.4		
22		19	16.5	15.4	7.8	6.6	3.6	3	2.5		
30		20.6	17.8	16.6	8.5	7.2	6.3	3.2	2.7	2.4	
37			18.8	17.5	15.2	7.6	6.6	3.4	2.8	2.5	
45			19.8	18.4	16	7.9	6.9	3.6	2.9	2.6	
55			21	19.3	16.8	8.4	7.3	6	3.1	2.7	
75				21.1	18.1	15.4	7.9	6.5	5.3	2.9	
90					19	16.1	14.1	6.7	5.6	3	
110					20.1	16.9	14.8	7.1	5.9		
132						17.7	15.4	7.9	6.2		
160						18.6	16.2	13.4	6.8		
180						19.2	16.7	13.8	7.2		
200							17.1	14.1			
225							17.6	14.6			
250							18.1	14.9			
280								15.3			
315								15.8			
350								17.1			

# TYPE FGO

Basic coupling of the FG series with connecting flange

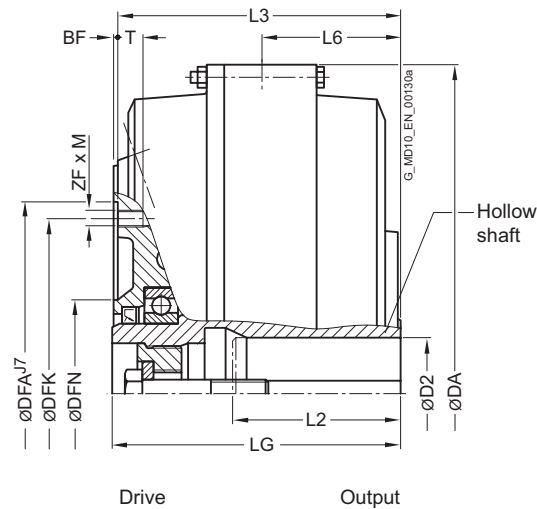

Size	Maximum speed $n_{Kmax}$ rpm	Installation dimensions							Flange connection dimensions						Tightening torque for screws in thread ZF · M $T_A$ Nm	Article no. <sup>1)</sup>	Weight $m$ kg
		D2 Keyway DIN 6885		L2 max. mm	DA mm	L3 mm	L6 mm	LG mm	DFN mm	DFA mm	BF mm	DFK mm	ZF · M	T mm			
		min. mm	max. mm														
370	3600	75	140	420	182	84	185	126	220	3	200	8 · M10	15	31	2LC0900-8CE09-0AA0	34	
425	3000	80	140	470	202	99	205	134	274	3	250	8 · M12	18	54	2LC0901-0CE09-0AA0	45	
490	2600	55	110	555	232	105	236	150	314	4	282	8 · M16	24	135	2LC0901-1CE09-0AA0	75	
		>55	75														140
		>75	100	170													
565	2300	110	170	630	250	123	254	166	344	4	312	8 · M16	24	135	2LC0901-2CE09-0AA0	95	
655	2000	130	210	736	296	145	301	180	430	5	390	8 · M20	25	260	2LC0901-3CE09-0AA0	142	
755	1800	150	240	840	341	176	346	226	480	5	440	10 · M20	25	260	2LC0901-4CE09-0AA0	208	
887	1500	150	275	990	391	217	396	249	520	5	480	10 · M20	25	260	2LC0901-5CE09-0AA0	362	

## Configurable variants <sup>1)</sup>

- Delivery without oil filling  
Delivery with oil filling with specification of oil filling quantity in l  
Delivery without oil filling with oil filling quantity specification in l

## Notes

- The specified coupling weights are effective for maximum bores without oil filling.
- Delivery with oil filling only above -20 °C

## Ordering example

- Motor 132 kW,  $P_{eff} = 110$  kW,  $n_1 = 1470$  rpm
- FLUDEX FGO coupling size 490
- Hollow shaft: Bore  $\text{ØD2} = 70\text{H7}$  mm with keyway to DIN 6885/1 and retaining screw
- Delivery with oil filling: 14.4 l (see Page 13/9)

Article no.: 2LC0901-1CE09-0AA0-Z L1G+F16+Y90

Plain text to Y90: 14.4 l

<sup>1)</sup> To identify complete item numbers specifying the available finish boring options and – if necessary – further order options, please use our configurators on [flender.com](http://flender.com).

↗ For online configuration on [flender.com](http://flender.com), click on the item no.

# TYPE FGD

with N-EUPEX D add-on coupling

Enables change of flexible elements without axial displacement of the shafts if the space "A" is provided.

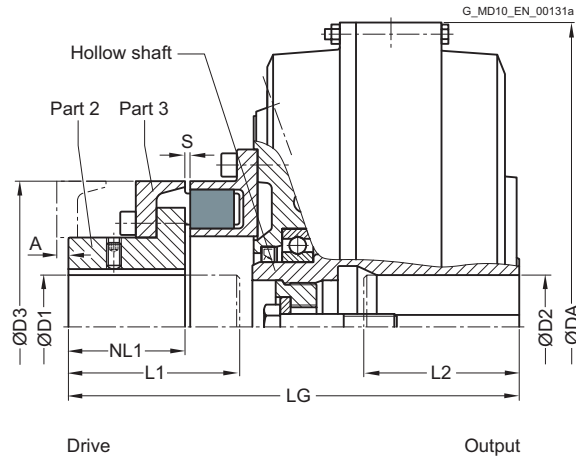

Size	Maximum speed $n_{Kmax}$ rpm	FLUDEX coupling					N-EUPEX D add-on coupling						Article no. <sup>1)</sup>	Weight <i>m</i> kg
		D2 Keyway DIN 6885 min. mm   max. mm		L2 max. mm	DA mm	LG mm	D1 max. mm	L1 max. mm	NL1 mm	Size D3 mm	S mm	A mm		
370	3600	75	140	420	298	80	110	70	180	4 <sup>+2</sup> <sub>-2</sub>	10	2LC0900-8CA	44	
425	3000	80	140	470	348	100	140	90	225	4 <sup>+2</sup> <sub>-2</sub>	9	2LC0901-0CA	66	
490	2600	55	110	555	397	115	155	100	250	5 <sup>+3</sup> <sub>-2</sub>	11	2LC0901-1CA	105	
		>55 >75	75 100											140 170
565	2300	110	170	630	430	125	170	110	280	5 <sup>+3</sup> <sub>-2</sub>	5	2LC0901-2CA	134	
655	2000	130	210	736	515	165	210	140	350	5 <sup>+3</sup> <sub>-2</sub>	0	2LC0901-3CA	217	
755	1800	150	240	840	584	180	230	160	400	5 <sup>+3</sup> <sub>-2</sub>	0	2LC0901-4CA	307	
887	1500	150	275	990	665	190	260	180	440	8 <sup>+2</sup> <sub>-3</sub>	0	2LC0901-5CA	491	

### Configurable variants<sup>1)</sup>

- ØD1 Without finished bore  
With finished bore
- Delivery without oil filling  
Delivery with oil filling with specification of oil filling quantity in l  
Delivery without oil filling with oil filling quantity specification in l

### Notes

- The specified coupling weights are effective for maximum bores without oil filling.
- Delivery with oil filling only above -20 °C

<sup>1)</sup> To identify complete item numbers specifying the available finish boring options and – if necessary – further order options, please use our configurators on [flender.com](http://flender.com).

↗ For online configuration on [flender.com](http://flender.com), click on the item no.

### Ordering example

- Motor 350 kW,  $P_{eff} = 315$  kW,  $n_1 = 1470$  rpm
- FLUDEX FGD coupling size 655, standard type
- Hollow shaft: Bore ØD2 = 120H7 mm with keyway to DIN 6885/1 and retaining screw
- Part 2: without finished bore (bore ØD1 = 110 mm or ØD1 = 130 mm) or with finished bore (bore ØD1 = 140H7 mm) with keyway to DIN 6885/1 and set screw
- Delivery without oil filling, no oil filling quantity specification

Article no. without finished bore for ØD1 = 110 mm:  
2LC0901-3CA19-0AA0-Z L1S

Article no. without finished bore for ØD1 = 130 mm:  
2LC0901-3CA29-0AA0-Z L1S

Article no. with finished bore for ØD1 = 140H7 mm:  
2LC0901-3CA99-0AA0-Z L1S+M1V

# TYPE FGE

with N-EUPEX E add-on coupling

Enables larger bores on the drive side.

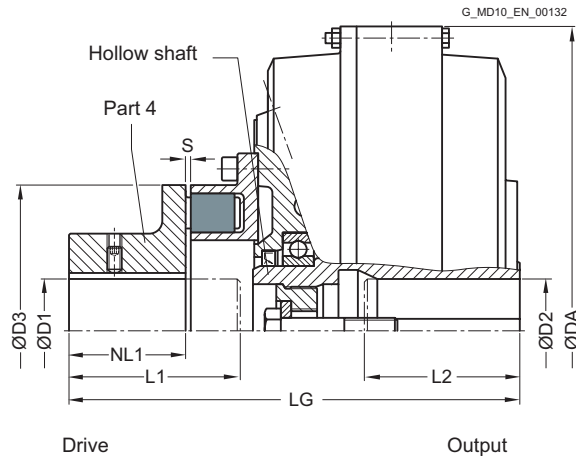

Size	Maximum speed $n_{Kmax}$ rpm	FLUDEX coupling					N-EUPEX E add-on coupling					Article no. <sup>1)</sup>	Weight <i>m</i> kg
		D2 Keyway DIN 6885		L2	DA	LG	D1	L1	NL1	Size D3	S		
		min. mm	max. mm	max. mm	mm	mm	max. mm	max. mm	mm	mm	mm		
370	3600	75		140	420	298	80	110	70	180	4 <sup>+2</sup> <sub>-2</sub>	2LC0900-8CB	44
425	3000	80		140	470	348	90	140	90	225	4 <sup>+2</sup> <sub>-2</sub>	2LC0901-0CB	64
490	2600	55		110	555	397	100	155	100	250	5 <sup>+3</sup> <sub>-2</sub>	2LC0901-1CB	101
		>55	75	140									
		>75	100	170									
565	2300	110		170	630	430	110	170	110	280	5 <sup>+3</sup> <sub>-2</sub>	2LC0901-2CB	129

13

### Configurable variants <sup>1)</sup>

- ØD1 Without finished bore  
With finished bore
- Delivery without oil filling  
Delivery with oil filling with specification of oil filling quantity in l  
Delivery without oil filling with oil filling quantity specification in l

### Notes

- The specified coupling weights are effective for maximum bores without oil filling.
- Delivery with oil filling only above -20 °C

### Ordering example

- Motor 160 kW,  $P_{eff} = 145$  kW,  $n_1 = 1485$  rpm
- FLUDEX FGE coupling size 490, vertical version, motor overhead
- Hollow shaft: Bore ØD2 = 60H7 with keyway to DIN 6885/1 and retaining screw
- Part 4: Bore ØD2 = 80H7 with keyway to DIN 6885/1 and set screw
- with seal set FPM
- Delivery with oil filling with specification of oil filling quantity

Article no.: 2LC0901-1CB99-0AA0-Z L1J+M1E+F08+F13+F16+Y90  
Plain text to Y90: 15.4 l

<sup>1)</sup> To identify complete item numbers specifying the available finish boring options and – if necessary – further order options, please use our configurators on [flender.com](http://flender.com).

↗ For online configuration on [flender.com](http://flender.com), click on the item no.



# TYPE FGM

with N-EUPEX M add-on coupling

Enables a short fitting length.

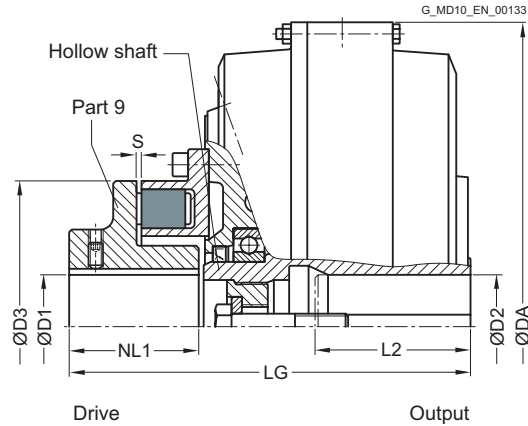

Size	Maximum speed $n_{Kmax}$ rpm	FLUDEX coupling					N-EUPEX M add-on coupling					Article no. <sup>1)</sup>	Weight <i>m</i> kg
		D2 Keyway DIN 6885 min. mm		L2 max. mm	DA mm	LG mm	D1 max. mm	L1 max. mm	NL1 mm	Size D3 mm	S mm		
370	3600	75	140	420	274	75	80	80	180	4 <sup>+2</sup> <sub>-2</sub>	2LC0900-8CD	44	
425	3000	80	140	470	310	90	100	100	225	4 <sup>+2</sup> <sub>-2</sub>	2LC0901-0CD	64	
		55	110	555	350								
490	2600	>55	75	140	555	100	105	105	250	5 <sup>+3</sup> <sub>-2</sub>	2LC0901-1CD	101	
		>75	100	170									
565	2300	110	170	630	380	110	120	120	280	5 <sup>+3</sup> <sub>-2</sub>	2LC0901-2CD	128	

## Configurable variants<sup>1)</sup>

- ØD1 Without finished bore  
With finished bore
- Delivery without oil filling  
Delivery with oil filling with specification of oil filling quantity in l  
Delivery without oil filling with oil filling quantity specification in l

## Notes

- The specified coupling weights are effective for maximum bores without oil filling.
- Delivery with oil filling only above -20 °C

## Ordering example

- Motor 45 kW,  $P_{eff} = 37$  kW,  $n_1 = 1470$  rpm
- FLUDEX FGM coupling size 370
- Hollow shaft: Bore ØD2 = 60H7 mm with keyway to DIN 6885/1 and retaining screw
- Part 4: Bore ØD1 = 60H7 mm with keyway to DIN 6885/1 and set screw.
- Delivery without oil filling, no oil filling quantity specification

Article no. with a keyway: 2LC0900-8CD99-0AA0-Z L1E+M1E

<sup>1)</sup> To identify complete item numbers specifying the available finish boring options and – if necessary – further order options, please use our configurators on [flender.com](http://flender.com).

➤ For online configuration on [flender.com](http://flender.com), click on the item no.

# OIL FILLING QUANTITIES FOR FG SERIES

This assignment is valid for a maximum starting torque  $T_{max} = 2.0 \cdot T_{eff}$  and mineral oils with a viscosity of VG 22/VG 32.

If other operating fluids are used, or with drive via the hollow shaft or  $T_{max} \neq 2.0 \cdot T_{eff}$  or  $T_{max} \neq 1.5 \cdot T_{eff}$ , changed filling quantities must be observed!

Sizes 370, 490, 655 and 887											
$P_{eff}$ kW	Speed in rpm										Size
	600	740	890	980	1180	1470	1770	2300	2950	3550	
Oil filling quantity in l											
1.1	5.2										
2.2	6.4										
3	7	5.9									
4	7.2	6.4	5.4								
5.5	13	6.9	6	5.4							
7.5	14.4	7.2	6.5	6	5.1						
11	15.9	13.3	7.2	6.7	5.7						
15	17	14.7	12.4	7.2	6.2						
18	28.9	15.4	13.1	12	6.5	5.4					
22	31.1	16.2	14	12.7	6.9	5.7	4.7				
30	35.9	17	15.2	14.1	11.8	6.3	5.3				
37	37.9	29.9	16.1	14.9	12.6	6.6	5.7				
45	39.7	32.3	17	15.7	13.4	7	6				
55	40	35.5	28.4	16.6	14.3	11.6	6.4	5			
75	70.5	38.7	31.7	28.5	15.5	12.7	6.9	5.5	4.3		
90	74.7	40	34.4	30.4	16.3	13.5	11.4	5.9	4.6		
110	81	40	37	33	27.3	14.4	12.1	6.2	4.9	4	
132	88.2	69.3	38.8	36	28.6	15.1	12.8	6.5	5.2	4.4	
160	93.5	73.3	40	37.8	30.6	15.9	13.6	10.6	5.5	4.7	370
200	98	79.8	67	39.9	33.7	26.9	14.6	11.4	6	5	
250	98	88.7	70.9	40	36.8	28.4	15.4	12.2		5.4	
315		94.7	76.6	69.8	39	30.8	26.2	13.1			490
350		97.2	80	71.8	39.9	32.2	26.9	13.6			
400		98	85.1	75.2	64.5	34.2	27.8				
500			92.4	82.5	68.1	37.1	29.7				655
600			96.9	90.1	71.5	38.8	31.9				
750			98	95.3	77.3	64	35.4				
900				98	83.7	67					
1100					91.1	70.4					887
1300					95.2	74.2					
1600						80.6					

Sizes 425, 565 and 755										
$P_{eff}$ kW	Speed in rpm								Size	
	600	740	890	980	1180	1470	1770	2300		2950
Oil filling quantity in l										
2.2	7.8									
3	8.7									
4	9.5	7.8								
5.5	10.3	8.7								
7.5	10.9	9.5	7.9							
11	19.9	10.5	9.1	8.2						
15	22	10.9	9.8	9.1						
18	23.2	19.1	10.3	9.6	8					
22	24.3	20.3	10.9	10.1	8.6					
30	40.2	22.4	18.9	10.9	9.5					
37	42.6	23.7	20.1	18.5	10	8.2				
45	45.8	24.9	21.5	19.5	10.5	8.8				
55	50.1	25.5	22.8	20.8	17.5	9.3	7.8			
75	55.6	43.8	24.6	22.9	19.3	10.1	8.6			
90	58.1	47.1	25.5	23.9	20.4	10.7	9.2	7.2		
110		51.7	41.5	25.5	21.8	17.7	9.7	7.6		
132		54.7	44	40.3	23	18.7	10.1	8.1	6.3	
160		57.4	47.5	42.5	24	19.8	16.7	8.6	6.8	
200		59	52.9	46.2	25.5	21.4	17.9	9.2	7.3	425
250			56	51.2	41.2	22.8	19.2	14.6	7.8	
315			59	55.1	44.4	24.2	20.6	16.1	8.3	
350				56.6	46.2	38	21.4	16.7		
400				58.4	49	39.3	22.2	17.4		565
500					53.7	41.6	36.3	18.7		
600					56.4	44.1	37.9			
750						48.4	40			755
900						52.8	42			
1100							45			

# TYPE FVO

Delay chamber coupling of the FV series with connecting flange.

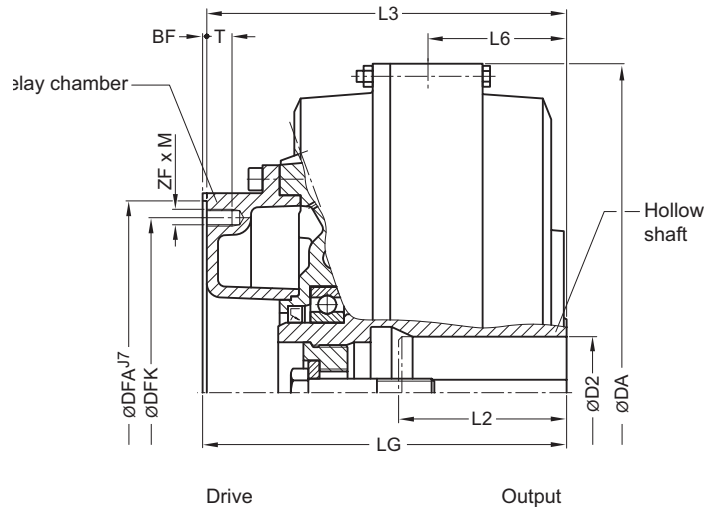

Size	Maximum speed $n_{Kmax}$ rpm	Installation dimensions							Flange connection dimensions					Tightening torque for screws in thread ZF · M $T_A$ Nm	Article no. <sup>1)</sup>	Weight $m$ kg
		D2 Keyway DIN 6885		L2	DA	L3	L6	L8	DFA	BF	DFK	ZF · M	T			
		min. mm	max. mm	max. mm	mm	mm	mm	mm	mm	mm	mm	mm	mm	mm		
370	3600	75	110	140	420	225	84	228	220	3	200	8 · M10	15	31	2LC0900-8ED09-0AA0	37
425	3000	80	110	140	470	257	99	260	274	3	250	8 · M12	18	54	2LC0901-0ED09-0AA0	47
490	2600	>55	75	140	555	297	105	301	314	4	282	8 · M16	24	135	2LC0901-1ED09-0AA0	80
		>75	100	170												
565	2300	110	110	170	630	333	123	337	344	4	312	8 · M16	24	135	2LC0901-2ED09-0AA0	103
655	2000	130	110	210	736	384	145	389	430	5	390	8 · M20	25	260	2LC0901-3ED09-0AA0	154
755	1800	150	110	240	840	440	176	445	480	5	440	10 · M20	25	260	2LC0901-4ED09-0AA0	224
887	1500	150	110	275	990	493	217	498	520	5	480	10 · M20	25	260	2LC0901-5ED09-0AA0	385

## Configurable variants <sup>1)</sup>

- Delivery without oil filling  
Delivery with oil filling with specification of oil filling quantity in l  
Delivery without oil filling with oil filling quantity specification in l

## Notes

- The specified coupling weights are effective for maximum bores without oil filling.
- Delivery with oil filling only above -20 °C

## Ordering example

- Motor 132 kW,  $P_{eff} = 110$  kW,  $n_1 = 1470$  rpm
- FLUDEX FVO coupling size 490
- Hollow shaft: Bore  $\varnothing D2 = 70H7$  mm with keyway to DIN 6885/1 and retaining screw
- Delivery with oil filling: 15.2 l (see Page 13/9)

Article no.: 2LC0901-1ED09-0AA0-Z L1G+F16+Y90

Plain text to Y90: 15.2 l

<sup>1)</sup> To identify complete item numbers specifying the available finish boring options and – if necessary – further order options, please use our configurators on [flender.com](http://flender.com).

↗ For online configuration on [flender.com](http://flender.com), click on the item no.

# TYPE FVD

with N-EUPEX D add-on coupling

Enables change of flexible elements without axial displacement of the shafts if the space "A" is provided.

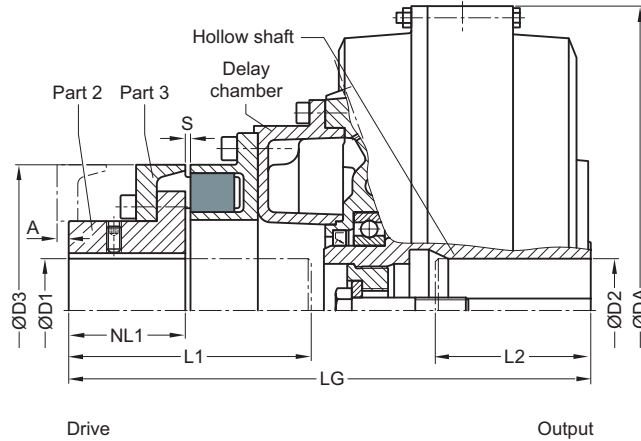

Size	Maximum speed $n_{Kmax}$ rpm	FLUDEX coupling					N-EUPEX D add-on coupling						Article no. <sup>1)</sup>	Weight <i>m</i> kg
		D2 Keyway DIN 6885		L2	DA	LG	D1	L1	NL1	Size D3	S	A		
		min. mm	max. mm	max. mm	mm	mm	max. mm	max. mm	mm	mm	mm	mm		
370	3600	75	140	420	341	80	150	70	180	4 <sup>+2</sup> <sub>-2</sub>	10	2LC0900-8EA	47	
425	3000	80	140	470	403	100	190	90	225	4 <sup>+2</sup> <sub>-2</sub>	9	2LC0901-0EA	68	
490	2600	55	110	555	462	115	220	100	250	5 <sup>+3</sup> <sub>-2</sub>	11	2LC0901-1EA	166	
		>55 >75	75 100											140 170
565	2300	110	170	630	513	125	250	110	280	5 <sup>+3</sup> <sub>-2</sub>	5	2LC0901-2EA	142	
655	2000	130	210	736	603	165	295	140	350	5 <sup>+3</sup> <sub>-2</sub>	0	2LC0901-3EA	229	
755	1800	150	240	840	683	180	330	160	400	5 <sup>+3</sup> <sub>-2</sub>	0	2LC0901-4EA	323	
887	1500	150	275	990	767	190	365	180	440	8 <sup>+2</sup> <sub>-3</sub>	0	2LC0901-5EA	514	

### Configurable variants<sup>1)</sup>

- ØD1 Without finished bore  
With finished bore
- Delivery without oil filling  
Delivery with oil filling with specification of oil filling quantity in l  
Delivery without oil filling with oil filling quantity specification in l

### Notes

- The specified coupling weights are effective for maximum bores without oil filling.
- Delivery with oil filling only above -20 °C

### Ordering example

- Motor 630 kW,  $P_{eff} = 500$  kW,  $n_1 = 1770$  rpm
- FLUDEX FVD coupling size 655
- Hollow shaft: Bore ØD2 = 95H7 with keyway to DIN 6885/1 and retaining screw,
- Part 2: Bore ØD2 = 110H7 with keyway to DIN 6885/1 and set screw
- with seal set FPM
- Delivery without oil filling with oil filling quantity specification [see Page 13/9]

Article no.: 2LC0901-3EA99-0AA0-Z L1Q+M1M+F08+Y90  
Plain text to Y90: 32.3 l

<sup>1)</sup> To identify complete item numbers specifying the available finish boring options and – if necessary – further order options, please use our configurators on [flender.com](http://flender.com).

↗ For online configuration on [flender.com](http://flender.com), click on the item no.

# TYPE FVE

with N-EUPEX E add-on coupling

Enables larger bores on the drive side.

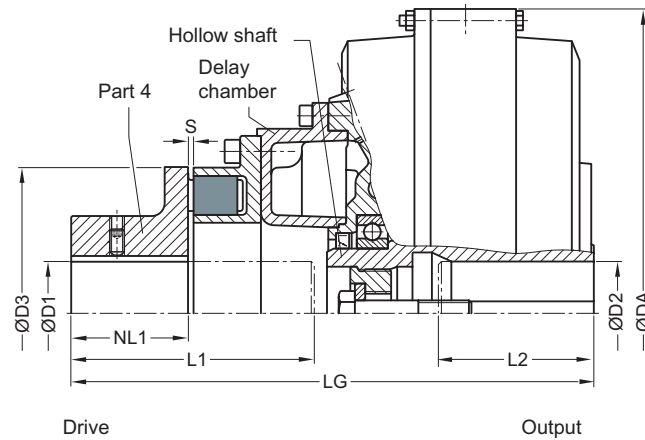

Size	Maximum speed $n_{Kmax}$ rpm	FLUDEX coupling					N-EUPEX E add-on coupling					Article no. <sup>1)</sup>	Weight <i>m</i> kg
		D2 Keyway DIN 6885		L2	DA	LG	D1	L1	NL1	Size D3	S		
		min. mm	max. mm	max. mm	mm	mm	max. mm	max. mm	mm	mm	mm		
370	3600	75	140	140	420	341	80	150	70	180	4 <sup>+2</sup> <sub>-2</sub>	2LC0900-8EB	47
425	3000	80	140	140	470	403	90	190	90	225	4 <sup>+2</sup> <sub>-2</sub>	2LC0901-0EB	66
490	2600	55	110	140	555	462	100	220	100	250	5 <sup>+3</sup> <sub>-2</sub>	2LC0901-1EB	107
		>55	75										
565	2300	110	170	170	630	513	110	250	110	280	5 <sup>+3</sup> <sub>-2</sub>	2LC0901-2EB	137

13

### Configurable variants <sup>1)</sup>

- ØD1 Without finished bore  
With finished bore
- Delivery without oil filling  
Delivery with oil filling with specification of oil filling quantity in l  
Delivery without oil filling with oil filling quantity specification in l

### Notes

- The specified coupling weights are effective for maximum bores without oil filling.
- Delivery with oil filling only above -20 °C

### Ordering example

- Motor 45 kW,  $P_{eff} = 37$  kW,  $n_1 = 1470$  rpm
- FLUDEX FVE coupling size 370
- Hollow shaft: Bore ØD2 = 60H7 mm with keyway to DIN 6885/1 and retaining screw
- Part 4: Bore ØD1 = 60H7 mm with keyway to DIN 6885/1 and set screw
- with electronic or mechanical operation monitoring, seal set NBR
- Delivery without oil filling, no oil filling quantity specification

Article no. with 110 °C thermal switch:  
2LC0900-8EB99-0AA0-Z L1E+M1E+F03

Article no. with 125 °C EOC transmitter:  
2LC0900-8EB99-0AA0-Z L1E+M1E+F04

<sup>1)</sup> To identify complete item numbers specifying the available finish boring options and – if necessary – further order options, please use our configurators on [flender.com](http://flender.com).

↗ For online configuration on [flender.com](http://flender.com), click on the item no.

# TYPE FVM

with N-EUPEX M add-on coupling

Enables a short fitting length.

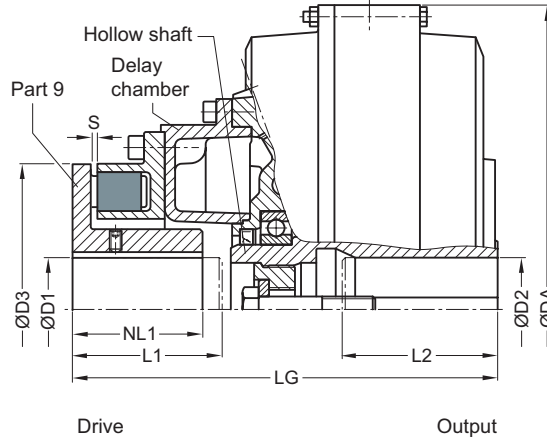

Size	Maximum speed $n_{Kmax}$ rpm	FLUDEX coupling					N-EUPEX M add-on coupling					Article no. <sup>1)</sup>	Weight <i>m</i> kg
		D2 Keyway DIN 6885		L2	DA	LG	D1	L1	NL1	Size D3	S		
		min. mm	max. mm	max. mm	mm	mm	max. mm	max. mm	mm	mm	mm		
370	3600		75	140	420	288	75	100	85	180	4 <sup>+2</sup> <sub>-2</sub>	2LC0900-8EC	46
425	3000		80	140	470	327	90	115	100	225	4 <sup>+2</sup> <sub>-2</sub>	2LC0901-0EC	65
490	2600		55	110	555	382	100	140	110	250	5 <sup>+3</sup> <sub>-2</sub>	2LC0901-1EC	104
		>55	75	140									
		>75	100	170									
565	2300		110	170	630	425	110	165	130	280	5 <sup>+3</sup> <sub>-2</sub>	2LC0901-2EC	135

## Configurable variants<sup>1)</sup>

- ØD1 Without finished bore  
With finished bore
- Delivery without oil filling  
Delivery with oil filling with specification of oil filling quantity in l  
Delivery without oil filling with oil filling quantity specification in l

## Notes

- The specified coupling weights are effective for maximum bores without oil filling.
- Delivery with oil filling only above -20 °C

## Ordering example

- Motor 250 kW,  $P_{eff} = 180$  kW,  $n_1 = 1470$  rpm
- FLUDEX FVM coupling size 565
- Hollow shaft: Bore ØD2 = 75H7 with keyway to DIN 6885/1 and retaining screw
- Part 9: Bore ØD2 = 95H7 with keyway to DIN 6885/1 and set screw
- with seal set NBR
- thermal control unit for temperature monitoring
- Delivery without oil filling without oil filling quantity specification

Article no.: 2LC0901-2EC99-0AA0-Z L1M+M1H+F03+F25

<sup>1)</sup> To identify complete item numbers specifying the available finish boring options and – if necessary – further order options, please use our configurators on [flender.com](http://flender.com).

➤ For online configuration on [flender.com](http://flender.com), click on the item no.

# OIL FILLING QUANTITIES FOR FV SERIES

This assignment is valid for a maximum starting torque  $T_{max} = 1.5 \cdot T_{eff}$  and mineral oils with a viscosity of VG 22/VG 32.

If other operating fluids are used, or with drive via the hollow shaft or  $T_{max} \neq 2.0 \cdot T_{eff}$  or  $T_{max} \neq 1.5 \cdot T_{eff}$ , changed filling quantities must be observed!

Sizes 370, 490, 655 and 887											
$P_{eff}$ kW	Speed in rpm										Size
	600	740	890	980	1180	1470	1770	2300	2950	3550	
Oil filling quantity in l											
1.1	5.3										
2.2	6.7	5.5									
3	7.4	6.1	5								
4	8	6.6	5.6	5							
5.5	13.8	7.4	6.2	5.6							
7.5	15.2	8	6.8	6.2	5.1						
11	17.4	14.1	7.7	7.1	5.9						
15	18.5	15.6	13	7.7	6.5	5.2					
18	31.6	16.6	13.8	12.5	6.9	5.5					
22	33.2	17.7	14.8	13.4	7.3	5.9	4.8				
30	36.5	18.5	16.3	14.9	12.3	6.5	5.5				
37	39.9	32.4	17.5	15.9	13.3	7	5.9	4.2			
45	44	34	18.5	17	14.1	7.5	6.2	4.6			
55	44	36.2	31	18.1	15.1	12	6.7	5.1			
75	75.8	41.4	33.6	31.2	16.7	13.5	7.4	5.7	4.2		
90	80	44	35.4	32.7	17.7	14.3	11.6	6.1	4.5		
110	74.3	44	38.2	34.5	29.9	15.2	12.6	6.4	5	4.1	
132	89.2	74.6	41.6	36.7	31.3	16.2	13.5	6.9	5.4	4.2	
160	96.3	78.7	44	39.8	32.9	17.3	14.4	10.4	5.7	4.6	370
200	107	83.6	72.1	44	34.9	29.4	15.4	11.7	6.2	5.1	
250	107	89.5	76.3	44	37.9	31.1	16.7	12.8		5.5	
315		98.5	81.5	75.6	42.1	33	28.6	13.9			490
350		103.6	83.7	77.7	44	33.9	29.5	14.4			
400		107	86.9	80.5	68.4	35.3	30.4				
500			94.5	85.3	73.8	38.4	32.3				655
600			102.9	90.6	77.3	41.8	33.8				
750			107	99.6	81.9	67.8	36.2				
900				107	86	72.7					
1100					92.3	76.2					887
1300					99.3	79.8					
1600						84					



Sizes 425, 565 and 755										
$P_{eff}$ kW	Speed in rpm									Size
	600	740	890	980	1180	1470	1770	2300	2950	
	Oil filling quantity in l									
2.2	8									
3	9.1									
4	9.9	8.1								
5.5	11.1	9								
7.5	12	9.9	8.3	7.4						
11	21.4	11.3	9.4	8.6						
15	23.7	12	10.4	9.5	7.8					
18	25.2	20.5	11.1	10.1	8.4					
22	27	21.9	11.7	10.8	9					
30	43.2	24.2	20.1	11.8	9.9	7.9				
37	45.7	26	21.7	19.5	10.7	8.6	6.7			
45	48.3	27.7	23.1	21	11.3	9.2	7.5			
55	51.2	28	24.6	22.5	18.3	9.7	8.1			
75	58	46.8	27.4	24.8	20.7	10.8	9	6.5		
90	63.7	49.2	28	26.5	22	11.4	9.5	7.1		
110		52.3	44.5	28	23.4	18.7	10.2	7.8		
132		56.3	46.9	43.3	24.9	19.9	10.9	8.4	6.1	
160		61.9	49.5	45.6	26.7	21.4	16.8	8.9	6.6	
200		65	53.2	48.6	41.7	23	18.9	9.6	7.3	425
250			58.6	51.9	44.2	24.7	20.6	14.7	8	
315			65	57	47.3	26.8	22.3	16.1	8.7	
350				60	48.6	40.3	23	16.8		
400				64.4	50.5	42.2	24	18.1		565
500					54.7	44.6	37.9	19.9		
600					59.5	47.1	40	21.2		
750						50	42.9			
900						53.2	45			755
1100							47.7			

# TYPE FNO

with large delay chamber and connecting shaft

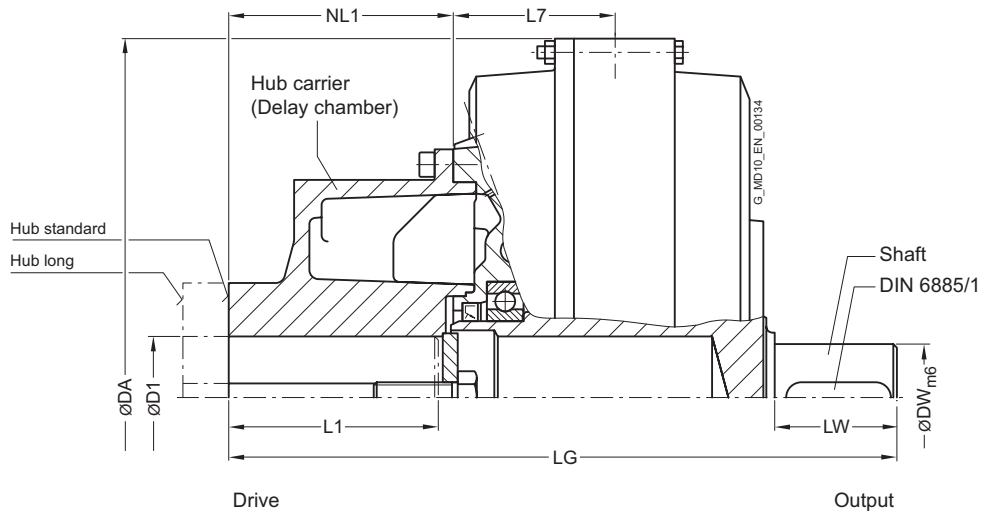

Size	Maximum speed $n_{Kmax}$ rpm	Hub carrier Hub	Installation dimensions							Connection dimensions		Article no. <sup>1)</sup>	Weight <i>m</i> kg
			D1 Keyway DIN 6885 min. mm	max. mm	L1 max. mm	NL1 mm	DA mm	L7 mm	LG mm	DW mm	LW mm		
370	3600	Standard	38	55	110	115	420	101	380	60	70	2LC0900-8GA	56
		Long	38	80	140	145	420		410				
425	3000	Standard	42	75	140	147	470	106	437	70	80	2LC0901-0GA	77
		Long	42	100	170	177	470		467				
490	2600	Standard	48	75	140	148	555	131	485	70	90	2LC0901-1GA	116
		Long	48	110	170	178	555		515				
565	2300	Standard	65	95	170	178	630	131	543	90	100	2LC0901-2GA	158
		Long	65	120	210	218	630		583				
655	2000	Standard	65	110	210	218	736	156	644	100	125	2LC0901-3GA	240
		Long	65	135	250	258	736		684				
755	1800	Standard	65	120	210	219	840	170	705	110	140	2LC0901-4GA	321
		Long	65	150	250	259	840		745				
887	1500	Standard	65	150	250	251	990	187	835	120	178	2LC0901-5GA	562
		Long	65	170	300	301	990		885				

### Configurable variants <sup>1)</sup>

- ØD1 Without finished bore  
With finished bore
- Delivery without oil filling  
Delivery with oil filling with specification of oil filling quantity in l  
Delivery without oil filling with oil filling quantity specification in l

### Notes

- The specified coupling weights are effective for maximum bores without oil filling.
- Delivery with oil filling only above -20 °C
- For mass moments of inertia, centroidal distance Y and weight FY, see Page 13/18.

### Ordering example

- Motor 110 kW,  $P_{eff} = 90$  kW,  $n_1 = 1470$  rpm, maximum output torque  $T_{max} = 1.3 \cdot T_{eff}$
- FLUDEX FNO coupling size 425
- Hub carrier: Standard hub bore ØD1 = 75H7 mm with keyway to DIN 6885/1 and retaining screw
- Seal set FPM
- Specification of oil filling quantity: 12.4 l (see Page 13/9)

Article no. with 160 °C fuse:

2LC0901-1GA90-1AA0-Z L1H+Y90+F08

Plain text to Y90: 12.4 l

<sup>1)</sup> To identify complete item numbers specifying the available finish boring options and – if necessary – further order options, please use our configurators on [flender.com](http://flender.com).

↗ For online configuration on [flender.com](http://flender.com), click on the item no.

# TYPE FNA

with large delay chamber and N-EUPEX A add-on coupling

Enables a short fitting length.

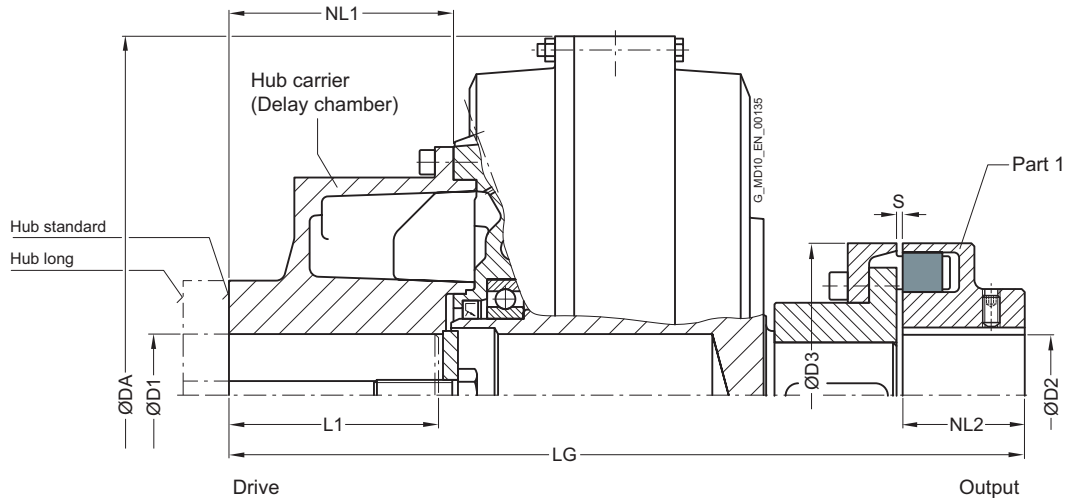

Size	Maximum speed $n_{kmax}$ rpm	Hub carrier Hub	FLUDEX coupling						N-EUPEX A add-on coupling				Article no. <sup>1)</sup>	Weight <i>m</i> kg
			D1 Keyway DIN 6885 min. mm	max. mm	L1 max. mm	NL1 mm	DA mm	LG mm	D2 max. mm	NL2 mm	Size D3 mm	S mm		
370	3600	Standard	38	55	110	115	420	454	80	70	180	4 <sup>+2</sup> <sub>-2</sub>	2LC0900-8GB	68
		Long	38	80	140	145	420	484					2LC0900-8GB	67
425	3000	Standard	42	75	140	147	470	521	85	80	200	4 <sup>+2</sup> <sub>-2</sub>	2LC0901-0GB	93
		Long	42	100	170	177	470	551					2LC0901-0GB	93
490	2600	Standard	48	75	140	148	555	579	90	90	225	4 <sup>+2</sup> <sub>-2</sub>	2LC0901-1GB	143
		Long	48	110	170	178	555	609					2LC0901-1GB	143
565	2300	Standard	65	95	170	178	630	648	100	100	250	5 <sup>+3</sup> <sub>-2</sub>	2LC0901-2GB	193
		Long	65	120	210	218	630	688					2LC0901-2GB	195
655	2000	Standard	65	110	210	218	736	774	120	125	315	5 <sup>+3</sup> <sub>-2</sub>	2LC0901-3GB	311
		Long	65	135	250	258	736	814					2LC0901-3GB	311
755	1800	Standard	65	120	210	219	840	850	140	140	350	5 <sup>+3</sup> <sub>-2</sub>	2LC0901-4GB	420
		Long	65	150	250	259	840	890					2LC0901-4GB	417
887	1500	Standard	65	150	250	251	990	1023	160	180	440	8 <sup>+2</sup> <sub>-3</sub>	2LC0901-5GB	726
		Long	65	170	300	301	990	1073					2LC0901-5GB	727

### Configurable variants<sup>1)</sup>

- ØD1 Without finished bore  
With finished bore
- ØD2 Without finished bore  
With finished bore
- Delivery without oil filling  
Delivery with oil filling with specification of oil filling quantity in l  
Delivery without oil filling with oil filling quantity specification in l

### Notes

- The specified coupling weights are effective for maximum bores without oil filling.
- Delivery with oil filling only above -20 °C
- For mass moments of inertia, centroidal distance Y and weight FY, see Page 13/18.

### Ordering example

- Motor 750 kW,  $P_{eff} = 600$  kW,  $n_1 = 980$  rpm
- FLUDEX FNA coupling size 887
- Hub carrier: Standard hub bore ØD1 = 40H7 with keyway to DIN 6885/1 and retaining screw
- Part 1: Bore ØD2 = 120H7 with keyway to DIN 6885/1 and set screw
- with seal set FPM
- EOC system for temperature monitoring
- Delivery without oil filling with oil filling quantity specification

#### Article no. with EOC system:

2LC0901-5GB99-1AA0-Z L1V+M1S+F12+F26+Y90

Plain text Y90: 90.6 l

<sup>1)</sup> To identify complete item numbers specifying the available finish boring options and – if necessary – further order options, please use our configurators on [flender.com](http://flender.com).

➤ For online configuration on [flender.com](http://flender.com), click on the item no.

# TYPE FND

with large delay chamber and N-EUPEX D add-on coupling

Enables fitting and dismantling of the coupling without displacement of the coupled shafts.

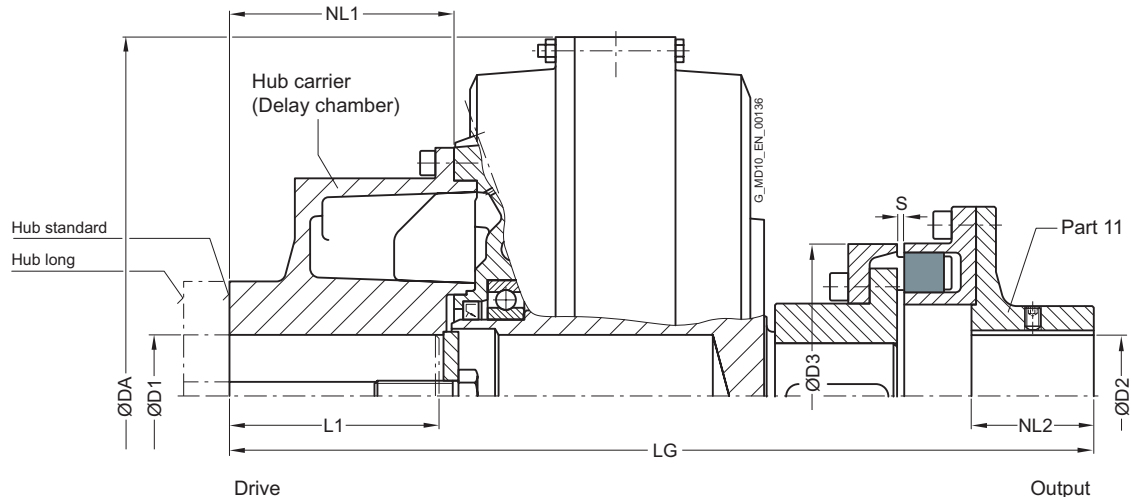

Size	Maximum speed $n_{Kmax}$ rpm	Hub carrier Hub	FLUDEX coupling						N-EUPEX D coupling				Article no. <sup>1)</sup>	Weight <i>m</i> kg
			D1 Keyway DIN 6885 min. mm	max. mm	L1 max. mm	NL1 mm	DA mm	LG mm	D2 max. mm	NL2 mm	Size D3 mm	S mm		
370	3600	Standard	38	55	110	115	420	494	70	70	180	5 <sup>+1</sup> <sub>-1</sub>	2LC0900-8GC	72
		Long	38	80	140	145	420	524					2LC0900-8GC	71
425	3000	Standard	42	75	140	147	470	566	80	80	200	5 <sup>+1</sup> <sub>-1</sub>	2LC0901-0GC	99
		Long	42	100	170	177	470	596					2LC0901-0GC	99
490	2600	Standard	48	75	140	148	555	629	90	90	225	5 <sup>+1</sup> <sub>-1</sub>	2LC0901-1GC	150
		Long	48	110	170	178	555	659					2LC0901-1GC	150

13

### Configurable variants <sup>1)</sup>

- ØD1 Without finished bore  
With finished bore
- ØD2 Without finished bore  
With finished bore
- Delivery without oil filling  
Delivery with oil filling with specification of oil filling quantity in l  
Delivery without oil filling with oil filling quantity specification in l

<sup>1)</sup> To identify complete item numbers specifying the available finish boring options and – if necessary – further order options, please use our configurators on [flender.com](http://flender.com).

↗ For online configuration on [flender.com](http://flender.com), click on the item no.

Size	Maximum speed $n_{Kmax}$ rpm	Hub carrier  Hub	FLUDEX coupling						N-EUPEX D coupling				Article no. <sup>1)</sup>	Weight <i>m</i> kg
			D1 Keyway DIN 6885		L1 max. mm	NL1 mm	DA mm	LG mm	D2 max. mm	NL2 mm	Size D3 mm	S mm		
			min. mm	max. mm										
565	2300	Standard	65	95	170	178	630	706	100	100	250	$\delta_{-1}^{+2}$	2LC0901-2GC	204
		Long	65	120	210	218	630	746					2LC0901-2GC	206
655	2000	Standard	65	110	210	218	736	842	110	125	315	$\delta_{-1}^{+2}$	2LC0901-3GC	324
		Long	65	135	250	258	736	882					2LC0901-3GC	324
755	1800	Standard	65	120	210	219	840	921	120	140	350	$\delta_{-1}^{+2}$	2LC0901-4GC	440
		Long	65	150	250	259	840	961					2LC0901-4GC	437
887	1500	Standard	65	150	250	251	990	1104	130	180	440	$\delta_{-2}^{+2}$	2LC0901-5GC	747
		Long	65	170	300	301	990	1154					2LC0901-5GC	748

### Configurable variants <sup>1)</sup>

- $\varnothing D1$  Without finished bore  
With finished bore
- $\varnothing D2$  Without finished bore  
With finished bore
- Delivery without oil filling  
Delivery with oil filling with specification of oil filling quantity in l  
Delivery without oil filling with oil filling quantity specification in l

### Notes

- The specified coupling weights are effective for maximum bores without oil filling.
- Delivery with oil filling only above -20 °C
- For mass moments of inertia, centroidal distance Y and weight FY, see **Page 13/18**.

### Ordering example

- Motor 132 kW,  $P_{eff} = 110$  kW,  $n_1 = 1470$  rpm
- FLUDEX FND coupling size 490
- Hub carrier: Long hub bore  $\varnothing D1 = 80H7$  mm with keyway to DIN 6885/1 and set screw
- Part 11: Bore  $\varnothing D1 = 80H7$  mm with keyway to DIN 6885/1 and set screw
- with electronic or mechanical operation monitoring
- seal set NBR
- Delivery without oil filling, no oil filling quantity specification

Article no, with 110 °C thermal switch:

2LC0901-1GC99-2AA0-Z L1J+M1J+F03

Article no. with 125 °C EOC transmitter:

2LC0901-1GC99-2AA0-Z L1J+M1J+F04

<sup>1)</sup> To identify complete item numbers specifying the available finish boring options and – if necessary – further order options, please use our configurators on [flender.com](https://www.flender.com).

➤ For online configuration on [flender.com](https://www.flender.com), click on the item no.

# TYPE FNDB

with large delay chamber, N-EUPEX A add-on coupling and brake drum

Enables fitting and dismantling of the coupling without displacement of the coupled shafts.

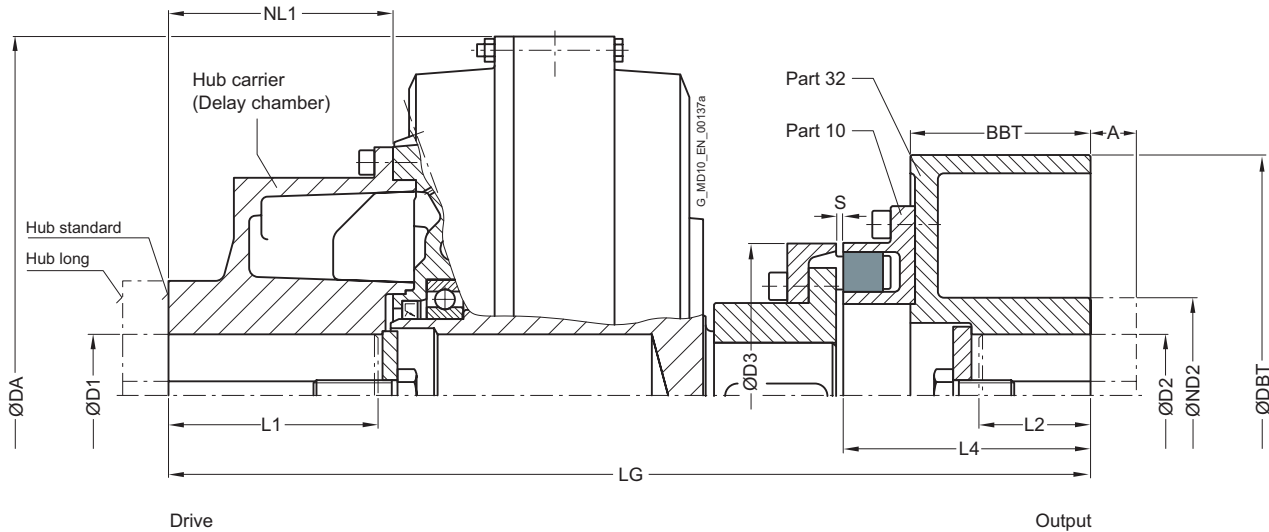

Size	Maximum speed $n_{Kmax}$ rpm	Hub carrier Hub	FLUDEX coupling						N-EUPEX D add-on coupling			Brake drum (Part 32)					Article no. <sup>1)</sup>	Weight m kg
			D1 Keyway DIN 6885 min. mm	max. mm	L1 max. mm	NL1 mm	DA mm	LG mm	Size D3 mm	S mm	L4 mm	D2 max. mm	ND2 mm	DBT mm	BBT mm	A mm		
370	3000	Standard	38	55	110	115	420	542	180	5 <sup>+1</sup> <sub>-1</sub>	157	80	128	315	118	50	2LC0900-8GD	87
		Long	38	80	140	145	420	572				90	160	400	150	80	2LC0900-8GD	86
	2300	Standard	38	55	110	115	420	574			189	90	160	400	150	80	2LC0900-8GD	110
		Long	38	80	140	145	420	604					162	80	128	315	118	50
425	3000	Standard	42	75	140	147	470	604	200	5 <sup>+1</sup> <sub>-1</sub>	162	80	128	315	118	50	2LC0901-0GD	113
		Long	42	100	170	177	470	634				90	160	400	150	80	2LC0901-0GD	113
	2300	Standard	42	75	140	147	470	636			194	90	160	400	150	80	2LC0901-0GD	137
		Long	42	100	170	177	470	666					194	90	160	400	150	80

### Configurable variants <sup>1)</sup>

- ØD1 Without finished bore  
With finished bore

---

- ØD2 Without finished bore  
With finished bore

---

- Part 32 Small brake drum  
Large brake drum

---

- Delivery without oil filling  
Delivery with oil filling with specification of oil filling quantity in l  
Delivery without oil filling with oil filling quantity specification in l

<sup>1)</sup> To identify complete item numbers specifying the available finish boring options and – if necessary – further order options, please use our configurators on [flender.com](http://flender.com).

↗ For online configuration on [flender.com](http://flender.com), click on the item no.

Size	Maximum speed $n_{Kmax}$ rpm	Hub carrier Hub	FLUDEX coupling						N-EUPEX D add-on coupling			Brake drum (Part 32)					Article no. <sup>1)</sup>	Weight <i>m</i> kg		
			D1 Keyway DIN 6885		L1	NL1	DA	LG	Size D3	S	L4	D2	ND2	DBT	BBT	A				
			min. mm	max. mm	max. mm	mm	mm	mm	mm	mm	mm	max. mm	mm	mm	mm	mm			mm	
490	2300	Standard	48	75	140	148	555	689	225	5 <sup>+1</sup> <sub>-1</sub>	199	90	160	400	150	80	2LC0901-1GD	183		
		Long	48	110	170	178	555	719				110	175	500	190	110	2LC0901-1GD	183		
	1900	Standard	48	75	140	148	555	729			250	6 <sup>+2</sup> <sub>-1</sub>	239	110	175	500	190	110	2LC0901-1GD	218
		Long	48	110	170	178	555	759						110	175	500	190	110	2LC0901-1GD	218
565	2300	Standard	65	95	170	178	630	756	315	6 <sup>+2</sup> <sub>-1</sub>			207	100	160	400	150	80	2LC0901-2GD	234
		Long	65	120	210	218	630	796						110	175	500	190	110	2LC0901-2GD	236
	1900	Standard	65	95	170	178	630	796			350	6 <sup>+2</sup> <sub>-1</sub>	247	110	175	500	190	110	2LC0901-2GD	268
		Long	65	120	210	218	630	836						110	175	500	190	110	2LC0901-2GD	270
655	1900	Standard	65	110	210	218	736	907	440	8 <sup>+2</sup> <sub>-2</sub>			257	110	175	500	190	110	2LC0901-3GD	377
		Long	65	135	250	258	736	947						140	224	630	236	100	2LC0901-3GD	377
	1500 <sup>2)</sup>	Standard	65	110	210	218	736	953			350	6 <sup>+2</sup> <sub>-1</sub>	303	140	224	630	236	100	2LC0901-3GD	437
		Long	65	135	250	258	736	993						140	224	630	236	100	2LC0901-3GD	437
755	1500 <sup>2)</sup>	Standard	65	120	210	219	840	1018	350	6 <sup>+2</sup> <sub>-1</sub>			307	140	224	630	236	100	2LC0901-4GD	541
		Long	65	150	250	259	840	1058						140	224	630	236	100	2LC0901-4GD	538
887	1300 <sup>3)</sup>	Standard	65	150	250	251	990	1190			440	8 <sup>+2</sup> <sub>-2</sub>	347	160	265	710	265	100	2LC0901-5GD	892
		Long	65	170	300	301	990	1240						160	265	710	265	100	2LC0901-5GD	893

Configurable variants <sup>1)</sup>

- ØD1 Without finished bore  
With finished bore
- ØD2 Without finished bore  
With finished bore
- Part 32 Small brake drum  
Large brake drum
- Delivery without oil filling  
Delivery with oil filling with specification of oil filling quantity in l  
Delivery without oil filling with oil filling quantity specification in l

Notes

- The specified coupling weights are effective for maximum bores without oil filling, without hub prolongations "A" but with set screw
- L2 denotes the shaft insertion depth.  
In the case of shaft ends deviating from DIN 748/1 long, the insertion depth must be specified in plain text with "Y29"
- Delivery with oil filling only above -20 °C
- For mass moments of inertia, centroidal distance Y and weight FY, see Page 13/18.

Ordering example:

- Motor 55 kW,  $P_{eff} = 45$  kW,  $n_1 = 1470$  rpm
- FLUDEX FNDB coupling size 370, standard type
- Hub carrier: Long hub bore ØD1 = 65H7 mm with keyway to DIN 6885/1 and set screw
- Brake drum (Part 32): Ø315 x 118, bore ØD2 = 80H7 mm with keyway to DIN 6885/1 and retaining screw
- seal set NBR
- Delivery without oil filling, no oil filling quantity specification

Article no.: 2LC0900-8GD99-2AA0-Z L1F+M1J

<sup>1)</sup> To identify complete item numbers specifying the available finish boring options and – if necessary – further order options, please use our configurators on [flender.com](http://flender.com).

<sup>2)</sup> When performing a GGG brake drum: Maximum speed 1800 min<sup>-1</sup> possible.

<sup>3)</sup> When performing a GGG brake drum: Maximum speed 1500 min<sup>-1</sup> possible.

➤ For online configuration on [flender.com](http://flender.com), click on the item no.

# TYPE FNDS SB

with large delay chamber, N-EUPEX D add-on coupling and brake disk for stopping brakes

Enables fitting and dismantling of the coupling without displacement of the coupled shafts.

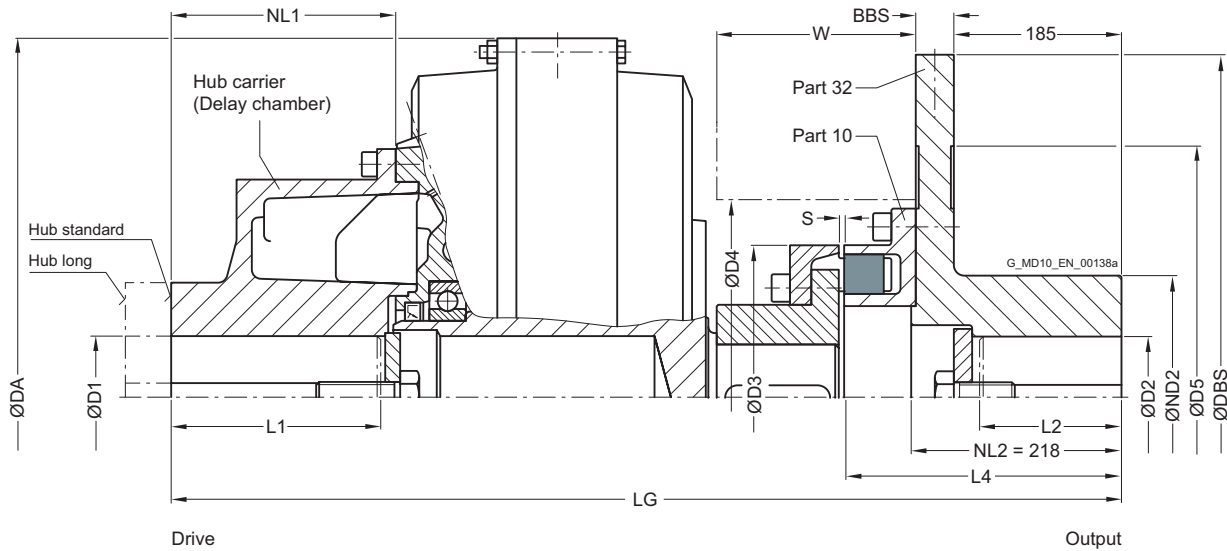

Size	Maximum speed $n_{Kmax}$ rpm	Hub carrier Hub	FLUDEX coupling						N-EUPEX D add-on coupling			Brake disk (part 32) <sup>2)</sup>					Space dimensions		Article no. <sup>1)</sup>	Weight <i>m</i> kg
			D1 Keyway DIN 6885 min. mm	max. mm	L1 max. mm	NL1 mm	DA mm	LG mm	Size D3 mm	S mm	L4 mm	D2 max. mm	ND2 mm	DBS mm	BBS mm	D5 mm	D4 mm	W mm		
370	3000	Standard	38	55	110	115	420	642	180	5 <sup>+1</sup> <sub>-1</sub>	257	80	145	450	30	300	222	130	2LC0900-8GE	116
		Long	38	80	140	145	420	672												
425	2600	Standard	42	75	140	147	470	704	200	5 <sup>+1</sup> <sub>-1</sub>	262	80	160	500	30	340	250	144	2LC0901-0GE	155
		Long	42	100	170	177	470	734												
490	2300	Standard	48	75	140	148	555	757	225	5 <sup>+1</sup> <sub>-1</sub>	267	90	160	560	30	370	276	162	2LC0901-1GE	212
		Long	48	110	170	178	555	787												

## Configurable variants <sup>1)</sup>

- ØD1 Without finished bore  
With finished bore
- ØD2 Without finished bore  
With finished bore
- Delivery without oil filling  
Delivery with oil filling with specification of oil filling quantity in l  
Delivery without oil filling with oil filling quantity specification in l

<sup>1)</sup> To identify complete item numbers specifying the available finish boring options and – if necessary – further order options, please use our configurators on [flender.com](http://flender.com).

<sup>2)</sup> Hub shortening possible, clearly specify NL2 size

↗ For online configuration on [flender.com](http://flender.com), click on the item no.



Size	Maximum speed $n_{Kmax}$ rpm	Hub carrier Hub	FLUDEX coupling						N-EUPEX D add-on coupling			Brake disk (part 32) <sup>2)</sup>					Space dimensions D4 W	Article no. <sup>1)</sup>	Weight <i>m</i> kg	
			D1 Keyway DIN 6885 min. mm	max. mm	L1 max. mm	NL1 mm	DA mm	LG mm	Size D3 mm	S mm	L4 mm	D2 max. mm	ND2 mm	DBS mm	BBS mm	D5 mm				
565	2100	Standard	65	95	170	178	630	824	250	6 <sup>+2</sup> <sub>-1</sub>	275	100	175	630	30	440	317	179	2LC0901-2GE	279
		Long	65	120	210	218	630	864												281
655	2000	Standard	65	110	210	218	736	935	315	6 <sup>+2</sup> <sub>-1</sub>	285	100	175	630	30	440	385	200	2LC0901-3GE	388
		Long	65	135	250	258	736	975												388
755	1800	Standard	65	120	210	219	840	1000	350	6 <sup>+2</sup> <sub>-1</sub>	289	140	220	710	30	520	435	219	2LC0901-4GE	518
		Long	65	150	250	259	840	1040												515
887	1500	Standard	65	150	250	251	990	1144	440	8 <sup>+2</sup> <sub>-2</sub>	301	140	220	800	30	610	525	268	2LC0901-5GE	828
		Long	65	170	300	301	990	1194												829

### Configurable variants<sup>1)</sup>

- ØD1 Without finished bore  
With finished bore
- ØD2 Without finished bore  
With finished bore
- Delivery without oil filling  
Delivery with oil filling with specification of oil filling quantity in l  
Delivery without oil filling with oil filling quantity specification in l

### Notes

- The specified coupling weights are effective for maximum bores without oil filling.
- L2 denotes the shaft insertion depth  
In the case of shaft ends deviating from DIN 748/1 long the insertion depth must be specified in plain text and with "Y29"
- Delivery with oil filling only above -20 °C
- For mass moments of inertia, centroidal distance Y and weight FY, see Page 13/18.

### Ordering example

- Motor 37 kW,  $P_{eff} = 30$  kW,  $n_1 = 1470$  rpm
- FLUDEX FNDS SB coupling size 370
- Hub carrier: Standard hub bore ØD1 = 55H7 mm with keyway to DIN 6885/1 and retaining screw
- Brake disk (part 32): Bore ØD2 = 75H7 mm with keyway to DIN 6885/1 and retaining screw
- with preservation suitable for indoor storage
- Delivery without oil filling, no oil filling quantity specification

Article no. with standard preservation:  
2LC0900-8GE99-1CA0-Z L1D+M1H

Article no. with preservation 6 months:  
2LC0900-8GE99-1CA0-Z L1D+M1H+B31

Article no. with preservation 24 months:  
2LC0900-8GE99-1CA0-Z L1D+M1H+B28

Article no. with preservation 36 months:  
2LC0900-8GE99-1CA0-Z L1D+M1H+B34

<sup>1)</sup> To identify complete item numbers specifying the available finish boring options and – if necessary – further order options, please use our configurators on [flender.com](http://flender.com).

<sup>2)</sup> Hub shortening possible, clearly specify NL2 size

↗ For online configuration on [flender.com](http://flender.com), click on the item no.

# TYPE FNDS HB

with large delay chamber, N-EUPEX D add-on coupling and brake disk for blocking brakes

Enables fitting and dismantling of the coupling without displacement of the coupled shafts.

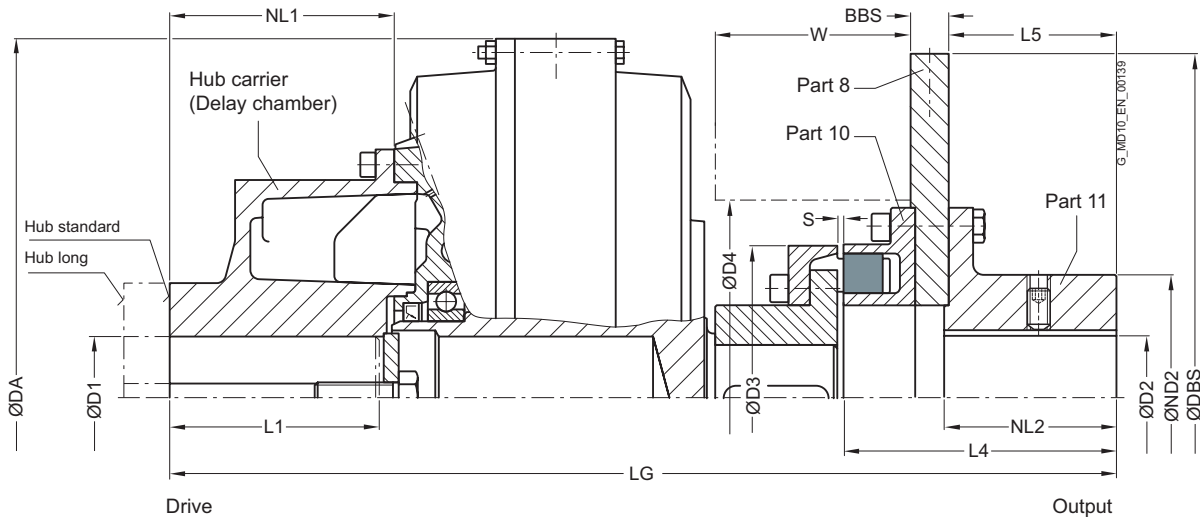

Size	Maximum speed $n_{Kmax}$ rpm	Hub carrier Hub	FLUDEX coupling						N-EUPEX D add-on coupling			Brake disk (part 8) Hub (part 11)					Space dimensions		Article no. <sup>1)</sup>	Weight <i>m</i> kg	
			D1 Keyway DIN 6885 min. mm	D1 Keyway DIN 6885 max. mm	L1 mm	NL1 mm	DA mm	LG mm	Size D3 mm	S mm	L4 mm	D2 max. mm	NL2 mm	ND2 mm	DBS mm	BBS mm	D5 <sup>2)</sup> mm	D4 mm			W mm
370	3600	Standard	38	55	110	115	420	555	180	5 <sup>+1</sup> <sub>-1</sub>	170	80	118	130	355	16	115	222	127	2LC0900-8GF	87
		Long	38	80	140	145	420	585													
425	3000	Standard	42	75	140	147	470	617	200	5 <sup>+1</sup> <sub>-1</sub>	175	80	118	130	355	16	115	250	141	2LC0901-0GF	115
		Long	42	100	170	177	470	647													
490	2600	Standard	48	75	140	148	555	670	225	5 <sup>+1</sup> <sub>-1</sub>	180	90	118	135	400	16	115	276	159	2LC0901-1GF	166
		Long	48	110	170	178	555	700													

### Configurable variants <sup>1)</sup>

- ØD1 Without finished bore  
With finished bore
- ØD2 Without finished bore  
With finished bore
- Delivery without oil filling  
Delivery with oil filling with specification of oil filling quantity in l  
Delivery without oil filling with oil filling quantity specification in l

<sup>1)</sup> To identify complete item numbers specifying the available finish boring options and – if necessary – further order options, please use our configurators on [flender.com](http://flender.com).

<sup>2)</sup> Hub shortening possible, clearly specify L5 size

↗ For online configuration on [flender.com](http://flender.com), click on the item no.

Size	Maximum speed $n_{Kmax}$ rpm	Hub carrier Hub	FLUDEX coupling						N-EUPEX D add-on coupling			Brake disk (part 8) Hub (part 11)					Space dimensions		Article no. <sup>1)</sup>	Weight $m$ kg	
			D1 Keyway DIN 6885	L1	NL1	DA	LG	Size D3	S	L4	D2	NL2	ND2	DBS	BBS	D5 <sup>2)</sup>	D4	W			
																					min. mm
565	2300	Standard	65	95	170	178	630	737	250	6 <sup>+2</sup> <sub>-1</sub>	188	100	118	160	450	16	115	317	176	2LC0901-2GF	224
		Long	65	120	210	218	630	777												2LC0901-2GF	226
655	2000	Standard	65	110	210	218	736	848	315	6 <sup>+2</sup> <sub>-1</sub>	198	100	118	170	500	16	115	385	197	2LC0901-3GF	347
		Long	65	135	250	258	736	888												2LC0901-3GF	347
755	1800	Standard	65	120	210	219	840	961	350	6 <sup>+2</sup> <sub>-1</sub>	250	140	164	225	630	20	160	435	215	2LC0901-4GF	495
		Long	65	150	250	259	840	1001												2LC0901-4GF	492
887	1500	Standard	65	150	250	251	990	1105	440	8 <sup>+2</sup> <sub>-2</sub>	262	140	164	225	710	20	160	525	264	2LC0901-5GF	799
		Long	65	170	300	301	990	1155												2LC0901-5GF	800

### Configurable variants <sup>1)</sup>

- ØD1 Without finished bore  
With finished bore
- ØD2 Without finished bore  
With finished bore
- Delivery without oil filling  
Delivery with oil filling with specification of oil filling quantity in l  
Delivery without oil filling with oil filling quantity specification in l

### Notes

- The specified coupling weights are effective for maximum bores without oil filling.
- L2 denotes the shaft insertion depth  
In the case of shaft ends deviating from DIN 748/1 long the insertion depth must be specified in plain text and with "Y29"
- Delivery with oil filling only above -20 °C
- For mass moments of inertia, centroidal distance Y and weight FY, see Page 13/18.

### Ordering example

- Motor 200 kW,  $P_{eff} = 160$  kW,  $n_1 = 1470$  rpm
- FLUDEX FNDS HB coupling size 490
- Hub carrier: Long hub bore ØD1 = 110H7 mm with keyway to DIN 6885/1 and set screw
- Hub (part 11): Bore ØD2 = 80H7 mm with keyway to DIN 6885/1 and set screw
- Fitting position: Horizontal/vertical motor underneath (MU)
- Delivery without oil filling, no oil filling quantity specification

Article no. in horizontal version:  
2LC0901-1GF99-2AA0-Z L1Q+M1J

Article no. in vertical version (MU):  
2LC0901-1GF99-2AA0-Z L1Q+M1J+F14

<sup>1)</sup> To identify complete item numbers specifying the available finish boring options and – if necessary – further order options, please use our configurators on [flender.com](http://flender.com).

<sup>2)</sup> Hub shortening possible, clearly specify L5 size

↗ For online configuration on [flender.com](http://flender.com), click on the item no.

# OIL FILLING QUANTITIES FOR FN SERIES

This assignment is valid for a maximum starting torque  $T_{max} = 1.3 \cdot T_{eff}$  and mineral oils with a viscosity of VG 22/VG 32.

If other operating fluids are used, or with drive via the shaft or  $T_{max} \neq 1.3 \cdot T_{eff}$ , changed filling quantities must be observed!

Sizes 370, 490, 655 and 887											
$P_{eff}$ kW	Speed in rpm										Size
	600	740	890	980	1180	1470	1770	2300	2950	3550	
Oil filling quantity in l											
1.1	5.6										
2.2	7.1	5.7									
3	7.9	6.4	5.1								
4	8.2	7	5.8	5.1							
5.5	14.4	7.8	6.5	5.9							
7.5	16	8.2	7.2	6.5	5.3						
11	18.2	14.7	8.2	7.4	6.2						
15	19	16.3	13.4	8.2	6.8	5.4					
18	33.5	17.3	14.4	12.9	7.2	5.8					
22	35.4	18.6	15.4	13.9	7.8	6.2	4.9				
30	38.5	19	17	15.5	12.5	6.9	5.7				
37	41.6	34.3	18.4	16.6	13.7	7.4	6.1	4.4			
45	45	36.2	19	17.7	14.7	7.9	6.6	4.7			
55	45	38.2	32.9	19	15.8	12.2	7	5.3			
75	76.5	43	35.8	33.1	17.4	14	7.8	6	4.3		
90	80.5	45	37.6	34.8	18.7	14.9	11.7	6.4	4.6		
110	85.2	45	40.1	36.7	31.8	16	13.1	6.8	5.1		
132	89.5	74.7	43.3	38.6	33.2	16.9	14	7.2	5.6	4.3	
160	95.6	80	45	41.5	35	18.1	15	10.7	6	4.7	
200	105.5	84.5	71.5	45	37.1	31.1	16.2	11.8	6.5	5.2	370
250	110	89.7	76.9	45	39.7	33	17.4	13.2		5.8	
315		97.5	82.4	76.5	43.8	35.1	30.2	14.5			490
350		102.1	84.6	78.4	45	36.1	31.2	15			
400		108.9	87.6	81.2	68	37.4	32.3				
500			94.1	86.1	73.3	40.2	34.2				655
600			101.4	90.6	78.1	43.5	35.9				
750			110	98.5	82.9	66.9	38.2				
900				107.2	86.8	72.7					
1100					92.1	77.1					887
1300					98.2	80.4					
1600						84.9					

Sizes 425, 565 and 755										Size
$P_{eff}$ kW	Speed in rpm								Oil filling quantity in l	
	600	740	890	980	1180	1470	1770	2300		2950
2.2	8.5									
3	9.7									
4	10.7	8.6								
5.5	12	9.7								
7.5	12.5	10.7	8.8	7.7						
11	22.6	12.2	10.2	9.2						
15	25.2	12.5	11.2	10.2	8.3					
18	26.6	21.4	12	10.8	8.9					
22	28.6	23.1	12.5	11.6	9.6					
30	44.1	25.7	21.1	12.5	10.7	8.5				
37	46.8	27.5	22.9	20.5	11.4	9.2	7.1			
45	49.5	29	24.5	22	12.3	9.8	7.8			
55	52.4	29	26.1	23.7	18.7	10.5	8.6			
75	58.5	47.8	29	26.3	21.7	11.6	9.7	6.9		
90	63.8	50.5	29	27.9	23.2	12.4	10.3	7.4		
110		53.5	45.6	29	24.9	19	11	8.3		
132		57	47.9	44.3	26.3	20.9	11.7	8.9	6.6	
160		62	50.8	46.7	28.1	22.5	17.4	9.6	6.9	
200		67	54.2	49.9	42.1	24.3	19.5	10.3	7.6	425
250			59	53.1	45.3	26.2	21.6	16	8.6	
315			66.2	57.6	48.3	28.3	23.5	16.7	9.3	
350				60.3	49.9	40.8	24.4	17.4		
400				64.4	51.8	42.6	25.5	18.5		565
500					55.4	45.7	37.8	20.8		
600					59.8	48.1	40.6	22.3		
750						51.3	43.7			
900						54.2	46.1			755
1100							48.8			
1200							50.1			

# SPARE AND WEAR PARTS

for standard catalog couplings

## Flexible elements for N-EUPEX add-on coupling

FLUDEX coupling			N-EUPEX coupling	Number flexibles	Article No. (FFA)
Series	Size	Type	Size	per set	for one set flexibles
FA	222	FAK <sup>1)</sup> ; FAKB <sup>1)</sup>	95	6	FFA:000001194870
		Other types	110	6	FFA:000001194871
	297	FAK <sup>1)</sup> ; FAKB <sup>1)</sup>	125	6	FFA:000001194872
		FAK <sup>2)</sup> ; FAKB <sup>2)</sup>	125	6	FFA:000001194873
		Other types	125	6	FFA:000001194873
	342	All types	140	6	FFA:000001194874
	395	FAD <sup>1)</sup> ; FAE <sup>1)</sup> ; FADB <sup>1)</sup>	225	8	FFA:000001194875
		FAD <sup>2)</sup> ; FAE <sup>2)</sup> ; FADB <sup>2)</sup>	225	8	FFA:000001194876
		Other types	225	8	FFA:000001194876
	450	FAD <sup>1)</sup> ; FAE <sup>1)</sup> ; FADB <sup>1)</sup>	250	8	FFA:000001194877
		FAD <sup>2)</sup> ; FAE <sup>2)</sup> ; FADB <sup>2)</sup>	250	8	FFA:000001194878
		Other types	250	8	FFA:000001194878
	516	FAD <sup>1)</sup> ; FADB <sup>1)</sup>	315	9	FFA:000001194879
		FAD <sup>2)</sup> ; FADB <sup>2)</sup>	315	9	FFA:000001194880
		Other types	315	9	FFA:000001194880
	590	All types until 2010	315	9	FFA:000001194879
All types from 2011 on		315	9	FFA:000001194880	
FG/FV	370	All types	180	8	FFA:000001194881
	425		225	8	FFA:000001194876
	490		250	8	FFA:000001194878
	565		280	8	FFA:000001194882
	655		350	9	FFA:000001194883
	755		400	10	FFA:000001194884
	887		440	10	FFA:000001194885
FN	370	FNDB ØDBT = 400 <sup>3)</sup>	200	8	FFA:000001194886
		All types	180	8	FFA:000001194881
	425	All types	200	8	FFA:000001194886
		FNDB ØDBT = 500 <sup>3)</sup>	250	8	FFA:000001194878
	490	All types	225	8	FFA:000001194876
		All types	250	8	FFA:000001194878
	655		315	9	FFA:000001194880
	755		350	9	FFA:000001194883
887		440	10	FFA:000001194885	

<sup>1)</sup> For couplings up to and including year of construction 2003.

<sup>2)</sup> For couplings from year of construction 2004.

<sup>3)</sup> For couplings up to and including year of construction 2007.

## Thermal equipment

FLUDEX size	Thread	Part no.	Fuse element	Response temperature	Marking	Article No. (FFA) for one unit
222	M10	103 + 104 <sup>1)</sup>	Fusible safety plug	110 °C	yellow	FFA:000001194896
		203 + 204 <sup>1)</sup>		140 °C	red	FFA:000001194897
				160 °C	green	FFA:000001194898
	M10	153 + 104 <sup>1)</sup>	Oil filler plug	-		FFA:000001194894
297	M10	153 + 104 <sup>1)</sup>	Oil filler plug	-		FFA:000001194894
297 - 887	M18 x 1.5	103 <sup>2)</sup>	Fusible safety plug	110 °C	yellow	FFA:000001250338
		203 <sup>2)</sup>		140 °C	red	FFA:000001250339
				160 °C	green	FFA:000001250380
	M18 x 1.5	110 <sup>2)</sup>	Thermal switch	110 °C		FFA:000001361795
		210 <sup>2)</sup>		140 °C		FFA:000001361796
	M18 x 1.5	153 <sup>2)</sup>	Oil filler plug (except size 887)	-		FFA:000001337653
		163 <sup>2)</sup>	Screw plug	-		
	-	301	Cut-out device	-		FFA:000000652020
	-	142 + 104 <sup>1)</sup>	EOC transmitter with seal	125 °C		FFA:000001194899
-	245	EOC sensor	-		FFA:000000361460	
-	244	Evaluation instrument EWD 20 to 250 V AC/DC	-		FFA:000001205294	
370 - 755	M10	173 + 174 <sup>1)</sup>	Oil drain plug - delay chamber	-		FFA:000001194894
887	M30 x 1.5	153 + 154 <sup>1)</sup>	Oil filler plug (up to and including year of construction 2007)	-		FFA:000001194893
		153 <sup>2)</sup>	Oil filler plug (from year of construction 2008)	-		FFA:000001349554
	M16	173 + 174 <sup>1)</sup>	Oil drain plug - delay chamber	-		FFA:000001194895

## Sealing and rolling bearing sets for the FA series (except type FAR)

FLUDEX size	Up to and including year of construction	From year of construction	Seal set material	Article No. (FFA) for one seal set	Article No. (FFA) for one rolling bearing set
222	2000	2001	NBR	FFA:000001194900	FFA:000001194800
			NBR	FFA:000001194901	FFA:000001194801
			FPM	FFA:000001194902	
297	2000	2001	NBR	FFA:000001194903	FFA:000001194802
			FPM	FFA:000001194904	
			NBR	FFA:000001194905	FFA:000001194803
342			FPM	FFA:000001194906	
			NBR	FFA:000001194907	FFA:000001194804
			FPM	FFA:000001194908	
395			NBR	FFA:000001194909	FFA:000001194805
			FPM	FFA:000001194910	
450			NBR	FFA:000001194911	FFA:000001194806
			FPM	FFA:000001194912	
516			NBR	FFA:000001194913	FFA:000001194807
			FPM	FFA:000001194914	
590			NBR	FFA:000001194915	FFA:000001194808
			FPM	FFA:000001194916	

<sup>1)</sup> With separate seal ring.

<sup>2)</sup> With built-in ring seal.

# SPARE AND WEAR PARTS

for standard catalog couplings

## Seal and rolling bearing sets for type FAR <sup>1)</sup>

FLUDEX size	Type	Up to and including year of construction	From year of construction	Seal set material	Article No. [FFA] for one seal set	Article No. [FFA] for one rolling bearing set
222	2 · SPZ 100		2000	NBR	FFA:000001194917	FFA:000001194809
				NBR	FFA:000001194918	FFA:000001194810
				FPM	FFA:000001194919	
3 · SPZ 160			2001	NBR	FFA:000001194920	FFA:000001194811
				FPM	FFA:000001194921	
297	5 · SPZ 140	2000		NBR	FFA:000001194922	FFA:000001194812
				FPM	FFA:000001194923	
	7 · SPZ 140	2000		NBR	FFA:000001194924	FFA:000001194813
				FPM	FFA:000001194925	
	5 · SPZ 150	2001		NBR	FFA:000001194926	FFA:000001194814
4 · SPA 190	FPM			FFA:000001194927		
5 · SPA 224	2001		NBR	FFA:000001194928		
			FPM	FFA:000001194929		
342	5 · SPA 180			NBR	FFA:000001194930	FFA:000001194815
				FPM	FFA:000001194931	
	7 · SPA 180	2000		NBR	FFA:000001194932	FFA:000001194816
				FPM	FFA:000001194933	
395	5 · SPB 224			NBR	FFA:000001194934	FFA:000001194817
				FPM	FFA:000001194935	
	7 · SPB 224	2000		NBR	FFA:000001194936	FFA:000001194818
				FPM	FFA:000001194937	
	7 · SPB 236	2001		NBR	FFA:000001194938	FFA:000001194819
FPM	FFA:000001194939					
7 · SPB 280	2001		NBR	FFA:000001194938		
			FPM	FFA:000001194939		
450	8 · SPB 250	2000		NBR	FFA:000001194940	FFA:000001194820
				FPM	FFA:000001194941	
		2001		NBR	FFA:000001194942	FFA:000001194821
	FPM			FFA:000001194943		
	2001		NBR	FFA:000001194944	FFA:000001194822	
FPM			FFA:000001194945			
10 · SPB 250	2000		NBR	FFA:000001194946	FFA:000001194823	
			FPM	FFA:000001194947		
516	10 · SPB 315	2000		NBR	FFA:000001194948	FFA:000001194824
				FPM	FFA:000001194949	
	2001		NBR	FFA:000001194950	FFA:000001194825	
			FPM	FFA:000001194951		
12 · SPB 315	2000		NBR	FFA:000001194952	FFA:000001194826	
			FPM	FFA:000001194953		
590	12 · SPC 315	2000		NBR	FFA:000001194954	FFA:000001194827
				FPM	FFA:000001194955	
				2001		NBR
				FPM	FFA:000001194957	

<sup>1)</sup> Spare parts only suitable for specified belt pulleys.  
Please request a different number of grooves by specifying the original delivery number.



Seal and rolling bearing sets for the FG/FV/FN series

FLUDEX coupling							
Series	Size	Year of construction	Additional bore specifications	Seal set material	Article No. (FFA) for one seal set	Article No. (FFA) for one rolling bearing set	
FG	370	Up to and including year of construction 2000		NBR	FFA:000001194958	FFA:000001194850	
				FPM	FFA:000001194959		
		From year of construction 2001		NBR	FFA:000001194958	FFA:000001194851	
				FPM	FFA:000001194959		
	425			NBR	FFA:000001194962	FFA:000001194852	
				FPM	FFA:000001194963		
	490			NBR	FFA:000001194966	FFA:000001194853	
				FPM	FFA:000001194967		
	565			NBR	FFA:000001194970	FFA:000001194854	
				FPM	FFA:000001194971		
	655			ØD2 ≤ 100	NBR	FFA:000001194974	FFA:000001194855
					FPM	FFA:000001194975	
				ØD2 > 100	NBR	FFA:000001194976	FFA:000001194856
					FPM	FFA:000001194977	
755			ØD2 ≤ 110	NBR	FFA:000001194982	FFA:000001194857	
				FPM	FFA:000001194983		
			ØD2 > 110	NBR	FFA:000001194984	FFA:000001194858	
				FPM	FFA:000001194985		
887				FPM	FFA:000001194993	FFA:000001194860	
FV	370	Up to and including year of construction 2000		NBR	FFA:000001194960	FFA:000001194850	
				FPM	FFA:000001194961		
		From year of construction 2001			NBR	FFA:000001194960	FFA:000001194851
					FPM	FFA:000001194961	
	425				NBR	FFA:000001194964	FFA:000001194852
					FPM	FFA:000001194965	
	490				NBR	FFA:000001194968	FFA:000001194853
					FPM	FFA:000001194969	
	565				NBR	FFA:000001194972	FFA:000001194854
					FPM	FFA:000001194973	
	655			ØD2 ≤ 100	NBR	FFA:000001194978	FFA:000001194855
					FPM	FFA:000001194979	
				ØD2 > 100	NBR	FFA:000001194980	FFA:000001194856
					FPM	FFA:000001194981	
755			ØD2 ≤ 110	NBR	FFA:000001194986	FFA:000001194857	
				FPM	FFA:000001194987		
			ØD2 > 110	NBR	FFA:000001194988	FFA:000001194858	
				FPM	FFA:000001194989		
887				FPM	FFA:000001194992	FFA:000001194860	
FN	370	Up to and including year of construction 2000		NBR	FFA:000001194960	FFA:000001194850	
				FPM	FFA:000001194961		
		From year of construction 2001			NBR	FFA:000001194960	FFA:000001194851
					FPM	FFA:000001194961	
	425				NBR	FFA:000001194964	FFA:000001194852
					FPM	FFA:000001194965	
	490				NBR	FFA:000001194968	FFA:000001194853
					FPM	FFA:000001194969	
	565				NBR	FFA:000001194972	FFA:000001194854
					FPM	FFA:000001194973	
	655				NBR	FFA:000001194978	FFA:000001194855
					FPM	FFA:000001194979	
	755				NBR	FFA:000001194990	FFA:000001194859
					FPM	FFA:000001194991	
887				FPM	FFA:000001194992	FFA:000001194860	



# BACKLASH-FREE COUPLINGS SIPEX SERIES

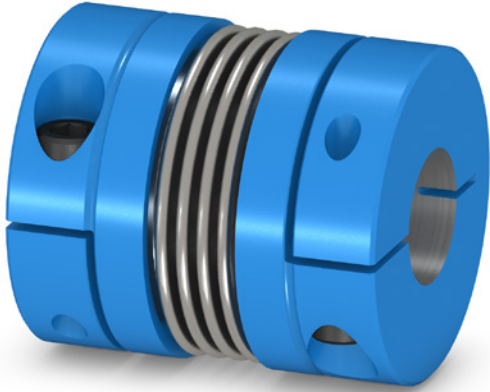

<b>General</b>	<b>14/2</b>
Benefits	14/2
Application	14/3
Design and configurations	14/3
Coupling dimensioning	14/5
Key to formula symbols	14/6
Technical information	14/7
Transmissible torques of the different clamping connections	14/9
<hr/>	
<b>Type SNN</b>	
Miniature series with set screws	14/10
<hr/>	
<b>Type SGS</b>	
Miniature series with expanding hub	14/11
<hr/>	
<b>Type SGG</b>	
Miniature series with clamping hub, slotted	14/12
<hr/>	
<b>Type SGG</b>	
Standard series with clamping hub, slotted	14/13
<hr/>	
<b>Type SGG-A</b>	
Miniature series with axially plug-in clamping hub	14/14
<hr/>	
<b>Type SGG-A</b>	
Standard series with axially plug-in clamping hub	14/15
<hr/>	
<b>Type SHH</b>	
Miniature series with half-shell clamping hub	14/16
<hr/>	
<b>Type SHH</b>	
Standard series with half-shell clamping hub	14/17
<hr/>	
<b>Type SKK</b>	
Miniature series with external taper	14/18
<hr/>	
<b>Type SKK</b>	
Standard series with external taper	14/19
<hr/>	
<b>Type SII</b>	
Standard series with internal taper	14/20
<hr/>	
<b>Type SHH-W</b>	
Standard series, drive shaft with half-shell clamping hubs	14/21
<hr/>	

# GENERAL

SIPEX couplings are torsionally rigid and backlash-free. They are characterized by their compact design and high power density. SIPEX couplings connect machine shafts and compensate for shaft misalignment that can occur during assembly or operation.

SIPEX couplings are suitable for all drive applications which require a coupling that offers positioning accuracy as well as a reliable, wear- and maintenance-free torque transmission.

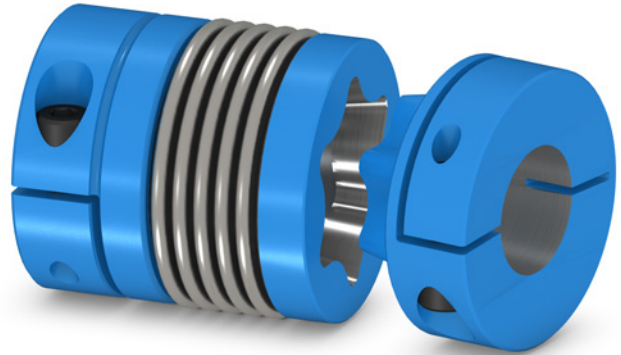

## Benefits

SIPEX couplings are suitable for mounting horizontally, vertically or in any desired position. The coupling parts can be arranged as required on the shaft ends to be connected.

The metal bellows are very torsional-resistant and combined with different clamping connections they ensure an absolutely angle-preserving torque transmission between the connected shafts. The moment of inertia is low.

SIPEX couplings compensate axial, radial and angular shaft misalignment with only low restoring forces. SIPEX couplings are wear-free within their technical limits and therefore offer an unlimited service life.



## Application

SIPEX couplings are available in 19 sizes within the standard catalog range, 7 of which are miniature versions and the other 12 standard designs. Rated torques range from 0.1 to 5000 Nm. The coupling is suitable for ambient temperatures of between -30 °C to +120 °C.

Couplings manufactured by alternative methods are available for higher ambient temperatures up to +250 °C.

SIPEX couplings from the standard range are especially suitable for application in highly dynamic drives such as, for example, linear axes in machine tools, packaging machines or printing presses, or generally for automation technology.

SIPEX couplings from the miniature range are designed for use in combination with rotary encoders, stepper motors or tachometers.

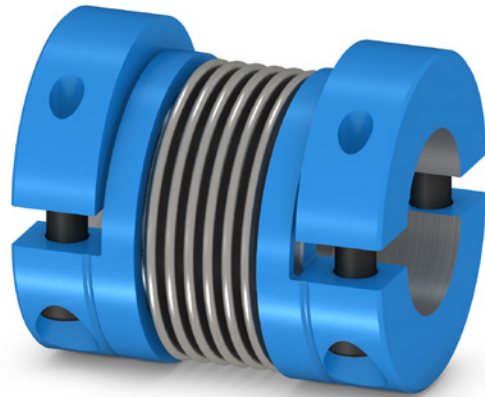

## Design and configurations

SIPEX couplings consist of two hub parts that are connected by means of bellows made of high-strength stainless steel.

The hubs can be coupled to the shafts by many different methods including set screws, key joint, slotted clamping hubs, halfshell hubs, clamping hubs or expanding hubs.

Thanks to their metal bellows, SIPEX couplings are torsionally rigid, but flexible. Misalignment between the connected shafts deforms the metal bellows.

## Coupling materials

Depending on the coupling version, hubs are made of aluminum (N, G, H) or steel (K, I), but stainless-steel variants are also optionally available.

All the metal bellows are made of stainless steel and are available as single-wall or multiple-wall devices depending on size and application. Metal bellows come in various standard lengths.

Metal bellows can be combined with different hub versions to create a complete unit. Once the hubs have been joined to metal bellows, they cannot be dismantled again.

## Hub versions

Hub	Description
N	Hub with set screws
G	Slotted clamping hub
H	Half-shell clamping hub
K	Clamping hub with external taper
I	Clamping hub with internal taper
S	Expanding hub

Hubs are supplied as standard with bore tolerance H7 and **without** keyway.

Versions N, G and H are optionally available with keyway in accordance with DIN 6885-1.

The fitting tolerance of the coupled shaft ends should be g6 or h7.

# GENERAL

## Versions of SIPEX couplings

Type	Description
SNN	Hub with set screw on both sides
SGG	Slotted clamping hub on both sides
SGG-A	Slotted clamping hub - for axial plug-in
SHH	Half-shell clamping hub on both sides
SKK	Clamping hub with external taper on both sides
SHH-W	Drive shaft with half-shell clamping hubs
SII	Clamping hubs with internal taper on both sides
SGS	Hub 1: Slotted, Hub 2: Expanding hub

## Hub variants

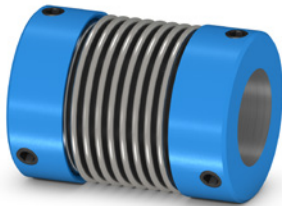

Set screw

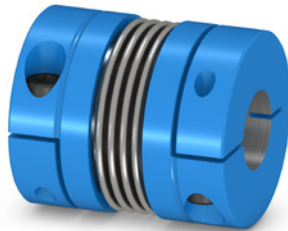

Clamping hub

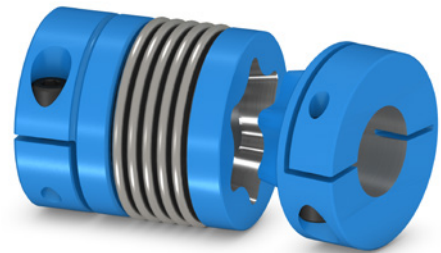

Axial plug-in

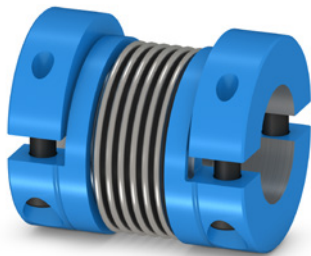

Half-shell clamping hub

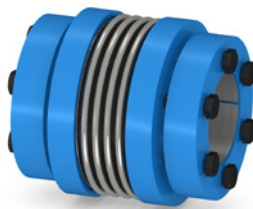

External taper

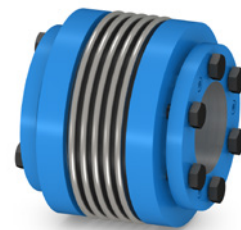

Internal taper

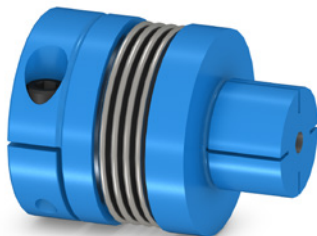

Expanding hub

## Coupling dimensioning

### Dimensioning according to torque

It must be ensured that the coupling is capable of safely transferring peak torques that regularly occur at the drive or load end. The service factor is provided in order to describe the deviation between the real coupling load and ideal load conditions:

$$T_{KN} \geq T_{AS} \cdot FB \text{ or } T_{LS} \cdot FB$$

Torque characteristic of drive	Service factor FB
Uniform	1.5
Non Uniform	2
Rough	2.5 - 4
Servomotors (machine tools)	1.5 - 2

### Dimensioning according to acceleration torques

The correct coupling size can be calculated more accurately on the basis of acceleration or deceleration torques because the peak torque at the coupling is reduced by the ratio between the moments of inertia on the drive and load ends:

$$T_{KN} \geq T_S \cdot FB$$

$$T_S = T_{AS} \cdot \frac{J_L}{J_A + J_L} \text{ or } T_S = T_{LS} \cdot \frac{J_A}{J_A + J_L}$$

### Checking the maximum torsion angle

If the application requires a maximum torsion angle of the coupling, the selected coupling size must be checked to ensure that it is sufficiently torsionally rigid for the application in question:

$$\varphi = \frac{180}{\pi} \cdot \frac{T_S}{C_{Tdyn}}$$

### Checking the maximum speed

For all load situations  $n_{Kmax} > n_{max}$

### Checking the permitted shaft misalignment

The actual shaft misalignment must be less than the permitted shaft misalignment for all load situations.

### Checking the shaft-hub connection

In the case of clamping connections without feather key, it must be ensured that the transmissible torque of the hub connection is greater than the peak torque at the coupling.

# GENERAL

## Key to formula symbols

Name	Formula symbol	Unit	Explanation
Rated coupling torque	$T_{KN}$	Nm	Torque which can be transmitted as static torque by the coupling over the period of use.
Coupling overload torque	$T_{KOL}$	Nm	Torque which can be transmitted very rarely as maximum torque by the coupling.
Peak torque at drive end	$T_{AS}$	Nm	Peak torque during non-periodic torque surges at drive end
Peak torque at load end	$T_{LS}$	Nm	Peak torque during non-periodic torque surges at load end
Peak torque	$T_S$	Nm	Peak torque at the coupling
Service factor	FB		Factor that expresses the real coupling load as a ratio of the nominal coupling load
Moment of inertia of drive end	$J_A$	kgm <sup>2</sup>	Sum of the moments of inertia at the drive end referred to the coupling speed
Moment of inertia of load end	$J_L$	kgm <sup>2</sup>	Sum of the moments of inertia at the load end referred to the coupling speed
Torsion angle	$\varphi$	°	Torsion angle of the coupling under torsional load
Torsional stiffness, dynamic	$C_{Tdyn}$	Nm/rad	Dynamic torsional stiffness of the coupling
Axial stiffness	$C_a$	N/mm	Axial stiffness of the coupling
Radial stiffness	$C_r$	N/mm	Radial stiffness of the coupling
Rated speed	$n_N$	rpm	Coupling speed
Maximum coupling speed	$n_{Kmax}$	rpm	Maximum permissible coupling speed
Axial misalignment	$\Delta K_a$	mm	Axial misalignment of the coupling halves
Radial misalignment	$\Delta K_r$	mm	Radial misalignment of the coupling halves
Angular misalignment	$\Delta K_w$	°	Angular misalignment of the coupling halves



Technical information

Power ratings of miniature series									
Size	Rated torque $T_{KN}$ Nm	Maximum torque $T_{KOL}$ Nm	Maximum speed $n_{Kmax}$ rpm	Torsional stiffness $C_{Tdyn}$ Nm/rad	Stiffness		Permitted shaft misalignment		
					radial $C_r$ N/mm	axial $C_a$ N/mm	$\Delta K_a$ mm	$\Delta K_r$ mm	$\Delta K_w$ °
1	0,1	0,15	15000	65	10	14	0,2	0,1	1,5
				258	128	18	0,2	0,1	1,5
5	0,5	0,75	15000	195	54	13	0,3	0,2	1,5
				160	26	11	0,4	0,2	2,0
10	1	1,5	15000	510	187	36	0,2	0,1	1,5
				380	82	27	0,3	0,2	1,5
15	1,5	2,25	15000	308	42	22	0,4	0,2	2,0
				750	139	23	0,3	0,1	1,5
20	2	3	15000	700	81	12	0,4	0,2	2,0
				1510	147	18	0,3	0,2	1,5
45	4,5	6,75	15000	1300	96	14	0,4	0,2	1,5
				1040	46	9	0,5	0,3	2,0
100	10	15	15000	6480	444	47	0,3	0,1	1,5
				4100	108	29	0,5	0,2	2,0
100	10	15	15000	8080	361	46	0,4	0,2	1,5
				6750	193	34	0,6	0,3	2,0

Power ratings of standard series									
Size	Rated torque $T_{KN}$ Nm	Maximum torque $T_{KOL}$ Nm	Maximum speed $n_{Kmax}$ rpm	Torsional stiffness $C_{Tdyn}$ Nm/rad	Stiffness		Permitted shaft misalignment		
					radial $C_r$ N/mm	axial $C_a$ N/mm	$\Delta K_a$ mm	$\Delta K_r$ mm	$\Delta K_w$ °
18	18	27	12800	19	200	50	0,5	0,2	1,5
				17	85	40	0,5	0,2	2,0
30	30	45	10300	36	720	50	0,5	0,2	1,5
				26	220	30	0,8	0,2	2,0
60	60	90	8700	75	1100	90	0,5	0,2	1,5
				50	330	55	0,8	0,2	2,0
80	80	120	6900	128	1200	80	0,5	0,2	1,5
				75	400	55	0,7	0,2	2,0
150	150	225	6900	155	2000	150	0,5	0,2	1,5
				102	600	85	0,6	0,2	2,0
200	200	300	6400	175	2500	150	0,5	0,2	1,5
				120	450	85	0,7	0,2	2,0
300	300	450	6000	502	6300	280	0,5	0,2	1,5
				282	1500	85	0,7	0,2	2,0
500	500	750	5000	690	8800	100	0,5	0,2	1,5
				315	1000	85	0,8	0,2	2,0
800	800	1200	3700	760	510	190	0,8	0,2	1,8
1400	1400	2100	3700	1300	710	280	0,8	0,2	1,8
3000	3000	4500	2800	2800	8060	880	0,8	0,2	1,5
5000	5000	7500	2800	4800	9190	740	0,8	0,2	1,5

# GENERAL

## Permitted shaft misalignment

---

The permitted shaft misalignments  $\Delta K_a$ ,  $\Delta K_r$  und  $\Delta K_w$  are maximum values and must not occur simultaneously. The following formula can be used to roughly calculate whether combinations of misalignments are permissible:

$$\frac{\Delta K_{r \text{ act}}}{\Delta K_r} + \frac{\Delta K_{a \text{ act}}}{\Delta K_a} + \frac{\Delta K_{w \text{ act}}}{\Delta K_w} < 1$$

The different torsional stiffness values apply to the various lengths of metal bellows of the relevant SIPEX type.

### Transmissible torques of the different clamping connections

Size	Transmissible torque of clamping connection in Nm as a function of hub design and shaft diameter																									
	Bore diameter D1/D2 in mm																									
	2	3	4	6	8	10	12	14	16	19	20	22	24	25	28	30	32	35	38	40	42	45	48	50	55	60
<b>Clamping hub (G hub)</b>																										
5	-	1.1	1.2	1.4	-	-	-	-	-	-	-	-	-	-	-	-	-	-	-	-	-	-	-	-	-	-
10	-	1.1	1.2	1.4	-	-	-	-	-	-	-	-	-	-	-	-	-	-	-	-	-	-	-	-	-	-
15	-	2.4	2.5	2.8	3.1	3.3	-	-	-	-	-	-	-	-	-	-	-	-	-	-	-	-	-	-	-	-
20	-	4.4	4.6	5.1	5.5	5.9	6.3	-	-	-	-	-	-	-	-	-	-	-	-	-	-	-	-	-	-	-
45	-	-	-	8.1	8.6	9.2	9.7	10.3	10.8	-	-	-	-	-	-	-	-	-	-	-	-	-	-	-	-	-
100	-	-	-	10.3	10.8	11.4	11.9	12.5	13.1	13.8	14.2	14.7	-	-	-	-	-	-	-	-	-	-	-	-	-	-
18	-	-	-	-	25.7	26.9	28.1	29.3	30.5	32.3	33	34	35.3	36	-	-	-	-	-	-	-	-	-	-	-	-
30	-	-	-	-	42.2	44	45.6	47.3	50	50.7	52.4	54	55	57.4	59	-	-	-	-	-	-	-	-	-	-	-
60	-	-	-	-	-	93	96	99	104	105	108	112	113	118	121	124	129	-	-	-	-	-	-	-	-	-
80	-	-	-	-	-	-	173	178	185	188	193	198	200	207	212	217	225	232	237	242	-	-	-	-	-	-
150	-	-	-	-	-	-	172	178	185	188	193	198	200	207	212	217	225	232	237	242	-	-	-	-	-	-
200	-	-	-	-	-	-	-	-	-	300	306	313	317	328	335	342	353	364	371	378	389	-	-	-	-	-
300	-	-	-	-	-	-	-	-	-	-	-	367	371	382	389	396	407	418	425	432	443	454	461	479	497	
500	-	-	-	-	-	-	-	-	-	-	-	-	-	-	-	-	588	603	613	623	638	658	662	687	712	
<b>Half-shell (H hub)</b>																										
5	-	0.6	0.8	1.3	1.7	2.1	-	-	-	-	-	-	-	-	-	-	-	-	-	-	-	-	-	-	-	-
10	-	0.6	0.8	1.3	1.7	2.1	-	-	-	-	-	-	-	-	-	-	-	-	-	-	-	-	-	-	-	-
15	-	1.1	1.4	2.1	2.8	3.5	4.2	-	-	-	-	-	-	-	-	-	-	-	-	-	-	-	-	-	-	-
20	-	1.6	2.2	3.2	4.3	5.4	6.5	-	-	-	-	-	-	-	-	-	-	-	-	-	-	-	-	-	-	-
45	-	-	-	5.5	7.4	9.2	11	12.9	14.7	-	-	-	-	-	-	-	-	-	-	-	-	-	-	-	-	-
100	-	-	-	5.5	7.4	9.2	11	12.9	14.7	16.6	18.4	20.2	-	-	-	-	-	-	-	-	-	-	-	-	-	-
18	-	-	-	-	12.2	15.2	18.3	21.3	24.4	29	30.5	33.5	36.6	38	-	-	-	-	-	-	-	-	-	-	-	-
30	-	-	-	-	21.5	25.8	30.1	34.4	40.9	43	47.3	51.6	53.9	60.2	64.5	-	-	-	-	-	-	-	-	-	-	-
60	-	-	-	-	47.4	55.3	63.2	75	79	87	95	99	111	119	126	138	-	-	-	-	-	-	-	-	-	-
80	-	-	-	-	-	88	100	120	126	138	151	157	176	189	201	220	239	251	264	-	-	-	-	-	-	-
150	-	-	-	-	-	88	100	120	126	138	151	157	176	189	201	220	239	251	264	-	-	-	-	-	-	-
200	-	-	-	-	-	-	-	-	-	183	202	220	229	257	275	293	321	348	367	385	413	-	-	-	-	-
300	-	-	-	-	-	-	-	-	-	-	-	220	229	257	275	293	321	348	367	385	413	440	458	504	550	
500	-	-	-	-	-	-	-	-	-	-	-	-	-	-	-	-	441	478	504	529	567	604	630	692	755	
<b>Internal taper (I hub)</b>																										
18	-	-	-	-	17	27	39	53	69	-	-	-	-	-	-	-	-	-	-	-	-	-	-	-	-	-
30	-	-	-	-	33	44	58	82	90	-	-	-	-	-	-	-	-	-	-	-	-	-	-	-	-	-
60	-	-	-	-	63	86	112	158	175	211	251	273	-	-	-	-	-	-	-	-	-	-	-	-	-	-
80	-	-	-	-	-	-	-	-	-	147	178	212	230	289	331	330	394	-	-	-	-	-	-	-	-	-
150	-	-	-	-	-	-	-	-	-	147	178	212	230	289	331	330	394	-	-	-	-	-	-	-	-	-
200	-	-	-	-	-	-	-	-	-	147	178	212	230	289	331	330	394	395	438	483	-	-	-	-	-	-
300	-	-	-	-	-	-	-	-	-	-	-	314	394	452	515	616	726	804	744	854	972	1055	-	-	-	
500	-	-	-	-	-	-	-	-	-	-	-	-	-	373	425	508	599	664	732	840	884	959	1160	-	-	
<b>External taper (K hub)</b>																										
18	-	-	-	-	22	35	50	68	-	-	-	-	-	-	-	-	-	-	-	-	-	-	-	-	-	-
30	-	-	-	-	39	53	69	97	108	-	-	-	-	-	-	-	-	-	-	-	-	-	-	-	-	-
60	-	-	-	-	-	-	65	92	102	123	147	159	200	229	261	-	-	-	-	-	-	-	-	-	-	-
80	-	-	-	-	-	-	-	-	131	159	189	205	257	295	336	402	-	-	-	-	-	-	-	-	-	-
150	-	-	-	-	-	-	-	-	131	159	189	205	257	295	336	402	-	-	-	-	-	-	-	-	-	-
200	-	-	-	-	-	-	-	-	151	182	217	235	295	339	285	341	402	446	491	-	-	-	-	-	-	-
300	-	-	-	-	-	-	-	-	-	-	-	328	412	472	538	643	758	687	757	869	1073	1126	-	-	-	
500	-	-	-	-	-	-	-	-	-	-	-	-	-	-	-	477	562	623	686	788	897	973	1177	-	-	
800	-	-	-	-	-	-	-	-	-	-	-	-	-	-	-	-	-	-	-	-	-	-	1773	2146	2553	
1400	-	-	-	-	-	-	-	-	-	-	-	-	-	-	-	-	-	-	-	-	-	-	1773	2146	2553	

■ Miniature series    ■ Standard series

# TYPE SNN

Miniature series with set screws

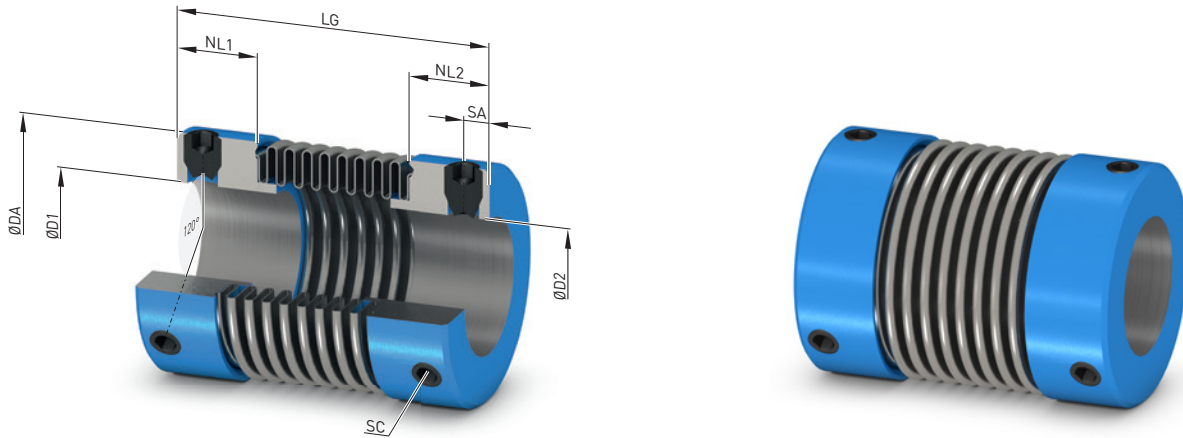

Size	Rated torque $T_{KN}$ Nm	Maximum speed $n_{K,max}$ rpm	Dimensions in mm					Screw DIN EN ISO 4027		Moment of inertia $J$ gcm <sup>2</sup>	Article No. <sup>1)</sup>	Weight $m$ g	
			DA	D1, D2 H7 min.   max.	NL1/ NL2	LG	SA	SC	$T_A$ Nm				
<b>Hub material aluminum</b>													
1	0,1	15000	10	2	5	4,2	22	2	M3	0,5	0,5	2LC0590-1AA99-0AA0	3
5	0,5	15000	15	3	8	6	19	2,2	M3	0,5	2	2LC0590-2AA99-0AA0	5,6
							23				2,1	2LC0590-2AA99-0AB0	6
10	1	15000	15	3	8	6	27	2,2	M3	0,5	2,3	2LC0590-2AA99-0AC0	6,5
							21				2,5	2LC0590-3AA99-0AA0	7
15	1,5	15000	20,5	3	12	8	25	3	M4	1,5	2,7	2LC0590-3AA99-0AB0	7,5
							29				2,9	2LC0590-3AA99-0AC0	8
20	2	15000	24,5	3	14	8,5	26	2,7	M4	1,5	8,7	2LC0590-4AA99-0AA0	13
							30				9,2	2LC0590-4AA99-0AB0	13,9
45	4,5	15000	32	6	18	12,3	27	4,5	M6	3	19,2	2LC0590-5AA99-0AA0	20,3
							33				23	2LC0590-5AA99-0AB0	23,8
100	10	15000	40	6	24	12,5	37	4,5	M6	3	26	2LC0590-5AA99-0AC0	26,5
							40				80	2LC0590-6AA99-0AA0	51
100	10	15000	40	6	24	12,5	48	4,5	M6	3	110	2LC0590-6AA99-0AB0	68
							45				188	2LC0590-7AA99-0AA0	74
							55				292	2LC0590-7AA99-0AB0	109

## Notes

- Shaft connected to hub by means of set screws according to EN ISO 4027. A keyway according to DIN 6885-1 can be selected additionally as an option.
- Weights and mass moments of inertia apply to maximum bore diameters.

## Ordering example

- SIPEX SNN coupling, size 45  
Total length LG = 40 mm
- Bore ØD1 14 H7
- Bore ØD2 18 H7

Article No.: 2LC0590-6AA99-0AA0-Z L0H+M0K

<sup>1)</sup> To identify complete item numbers specifying the available finish boring options and – if necessary – further order options, please use our configurators on [flender.com](http://flender.com).

↗ For online configuration on [flender.com](http://flender.com), click on the item no.

# TYPE SGS

Miniature series with expanding hub

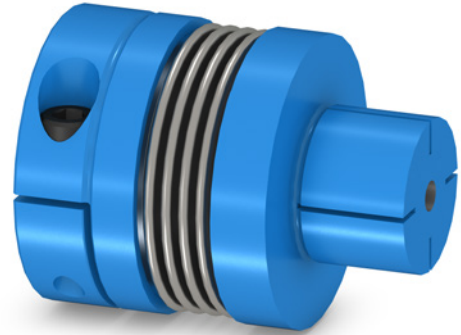
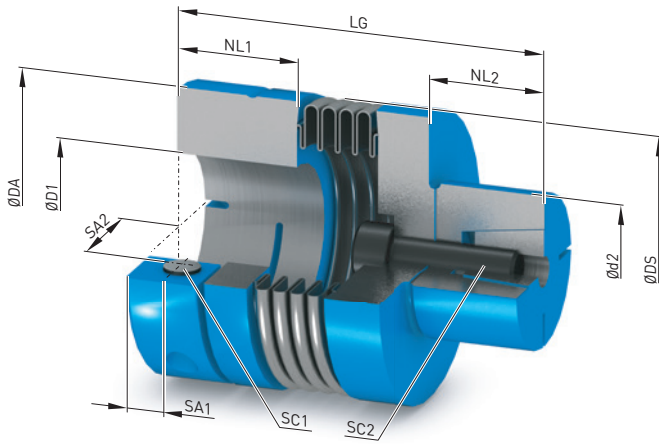

Size	Rated torque $T_{KN}$ Nm	Maximum speed $n_{Kmax}$ rpm	Dimensions in mm						Screw DIN EN ISO 4762				Moment of inertia $J$ gcm <sup>2</sup>	Article No. <sup>1)</sup>	Weight $m$ g				
			DA	DS	D1 H7 min.	max.	d2 h7	NL1	NL2	LG	SA1	SA2				SC1	$T_A$ Nm	SC2	$T_A$ Nm
<b>Hub material aluminum</b>																			
5	0.5	15000	15.5	17.5	3	7	8	6.8	8	28	2.4	5.2	M2	0.43	M3	1	2.5	2LC0590-2AD99-0AA0	9.3
										32							2.6	2LC0590-2AD99-0AB0	9.7
										36							2.8	2LC0590-2AD99-0AC0	10.1
10	1	15000	15.5	17.5	3	7	8	6.8	8	30	2.4	5.2	M2	0.43	M3	1	3	2LC0590-3AD99-0AA0	10.6
										34							3.2	2LC0590-3AD99-0AB0	11
										38							3.4	2LC0590-3AD99-0AC0	11.8
15	1.5	15000	20.5	21	3	10	10	8.5	12	37	3	7	M2.5	0.85	M4	3	7.8	2LC0590-4AD99-0AA0	18.5
										41							8.4	2LC0590-4AD99-0AB0	19.3
										46							20.6	2LC0590-5AD99-0AA0	27.8
20	2	15000	25.5	27	3	12.5	10	11	12	46	3.5	9	M3	2	M4	3	24.2	2LC0590-5AD99-0AB0	31.3
										50							27.7	2LC0590-5AD99-0AC0	34.8
										52							68	2LC0590-6AD99-0AA0	57
45	4.5	15000	32.5	34	6	16	14	13	16	60	4.5	11.5	M4	3.5	M5	5.9	99	2LC0590-6AD99-0AB0	74
										61							153	2LC0590-7AD99-0AA0	81
										71							257	2LC0590-7AD99-0AB0	117

## Notes

- A hollow shaft can be connected to the expanding hub.
- The bore for connecting the expanding hub must have tolerance H7.
- Weights and mass moments of inertia apply to maximum bore diameters.

## Ordering example

- SIPEX SGS coupling, size 45  
Total length LG = 52 mm
- Bore ØD1 14 H7
- Shaft Ød2 14 h7

Article No.: 2LC0590-6AD99-0AA0-Z L0H

<sup>1)</sup> To identify complete item numbers specifying the available finish boring options and – if necessary – further order options, please use our configurators on [flender.com](http://flender.com).

➤ For online configuration on [flender.com](http://flender.com), click on the item no.

# TYPE SGG

Miniature series with clamping hub, slotted

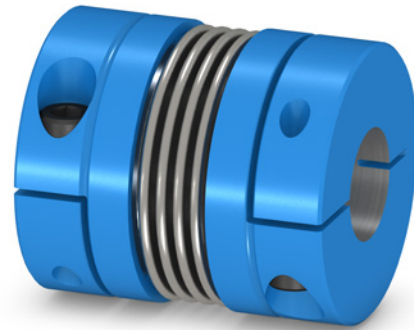
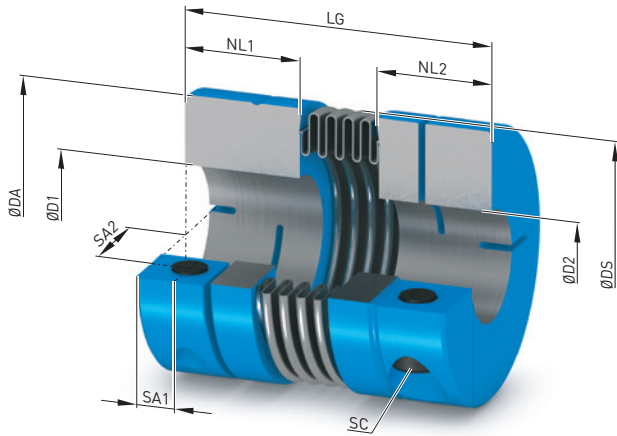

Size	Rated torque $T_{KN}$ Nm	Maximum speed $n_{Kmax}$ rpm	Dimensions in mm						Screw DIN EN ISO 4762		Moment of inertia $J$ gcm <sup>2</sup>	Article No. <sup>1)</sup>	Weight $m$ g		
			DA	DS	D1, D2 H7 min.   max.	NL1/ NL2	LG	SA1	SA2	SC				$T_A$ Nm	
<b>Hub material aluminum</b>															
5	0.5	15000	15.5	17.5	3	7	6.8	21	2.5	5.3	M2	0.3	2.4	2LC0590-2AB99-0AA0	6.6
								25					2.5	2LC0590-2AB99-0AB0	7
								28					2.7	2LC0590-2AB99-0AC0	7.5
10	1	15000	15.5	17.5	3	7	6.8	23	2.5	5.3	M2	0.3	2.9	2LC0590-3AB99-0AA0	7.9
								27					3.1	2LC0590-3AB99-0AB0	8.5
								31					3.3	2LC0590-3AB99-0AC0	9
15	1.5	15000	20	21	3	10	8.5	27	3	7	M2.5	0.8	7.7	2LC0590-4AB99-0AA0	12.5
								31					8.3	2LC0590-4AB99-0AB0	13.3
								32					24	2LC0590-5AB99-0AA0	25
20	2	15000	25	27	3	12.5	11	38	3.5	9	M3	1.5	28	2LC0590-5AB99-0AB0	28
								42					31	2LC0590-5AB99-0AC0	31
								42					80	2LC0590-6AB99-0AA0	49
45	4.5	15000	32.5	34	6	16	13	50	4.5	12	M4	3	110	2LC0590-6AB99-0AB0	66
								48					193	2LC0590-7AB99-0AA0	74
								57					298	2LC0590-7AB99-0AB0	110

14

### Notes

- The slotted clamping hub allows a frictionally engaged connection to the input and output shaft.
- A single tightening screw per hub ensures easy assembly.
- The maximum torques that can be transmitted by the clamping connection are listed in the table on page 14/9.
- A keyway according to DIN 6885-1 can be selected additionally as an option.
- Weights and mass moments of inertia apply to maximum bore diameters.

### Ordering example

- SIPEX SGG coupling, size 45,  
Total length LG = 42 mm
- Bore ØD1 12 H7
- Bore ØD2 16 H7

Article No.: 2LC0590-6AB99-0AA0 LG+M0J

<sup>1)</sup> To identify complete item numbers specifying the available finish boring options and – if necessary – further order options, please use our configurators on [flender.com](http://flender.com).

➤ For online configuration on [flender.com](http://flender.com), click on the item no.

# TYPE SGG

Standard series with clamping hub, slotted

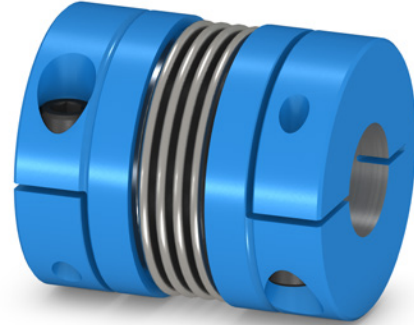
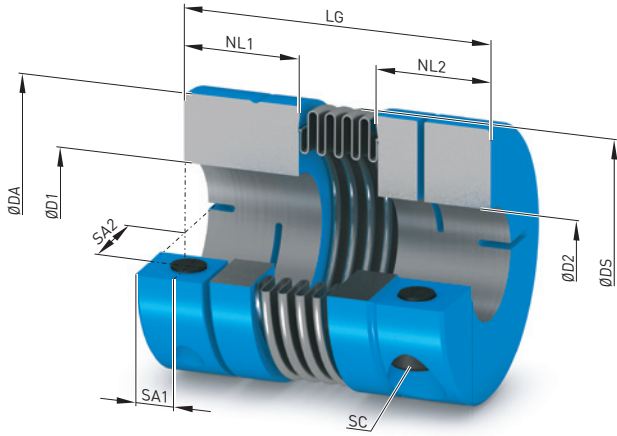

Size	Rated torque $T_{KN}$ Nm	Maximum speed $n_{Kmax}$ rpm	Dimensions in mm								Screw DIN EN ISO 4762		Moment of inertia $J$ $10^{-3} \cdot \text{kgm}^2$	Article No. <sup>1)</sup>	Weight $m$ kg
			DA	DS	D1, D2 H7 min. max.	NL1/ NL2	LG	SA1	SA2	SC	$T_A$ Nm				
<b>Hub material aluminum</b>															
18	18	12800	45	47	8	25	20,5	$\frac{63}{72}$	5,7	17,5	M5	8	0,05 0,06	2LC0590-8AB99-0AA0 2LC0590-8AB99-0AB0	0,14 0,15
30	30	10300	54	56	10	30	24,5	$\frac{65}{74}$	7,5	20	M6	15	0,11 0,12	2LC0591-0AB99-0AA0 2LC0591-0AB99-0AB0	0,23 0,25
60	60	8700	65	67	12	35	29	$\frac{79}{89}$	10	24	M8	40	0,31 0,32	2LC0591-1AB99-0AA0 2LC0591-1AB99-0AB0	0,44 0,45
80	80	6900	79	84	14	42	34	$\frac{92}{103}$	11,8	28	M10	72	0,76 0,82	2LC0591-2AB99-0AA0 2LC0591-2AB99-0AB0	0,74 0,79
150	150	6900	79	84	14	42	34	$\frac{92}{103}$	11,8	28	M10	84	0,76 0,82	2LC0591-3AB99-0AA0 2LC0591-3AB99-0AB0	0,74 0,79
200	200	6400	90	93	20	43	38	$\frac{101}{113}$	12,5	31,5	M12	125	1,41 1,5	2LC0591-4AB99-0AA0 2LC0591-4AB99-0AB0	1,1 1,17
300	300	6000	109	110	24	50	38	$\frac{103}{116}$	13	35	M12	145	3 3,2	2LC0591-5AB99-0AA0 2LC0591-5AB99-0AB0	1,7 1,75
500	500	5000	119	122	35	60	41,5	$\frac{111}{123}$	15	42	M14	190	4,5 4,7	2LC0591-6AB99-0AA0 2LC0591-6AB99-0AB0	1,99 2,05

## Notes

- The slotted clamping hub allows a frictionally engaged connection to the input and output shaft.
- A single tightening screw per hub ensures easy assembly.
- The maximum torques that can be transmitted by the clamping connection are listed in the table on [page page 14/9](#).
- A keyway according to DIN 6885-1 can be selected additionally as an option.
- Weights and mass moments of inertia apply to maximum bore diameters.

## Ordering example

- SIPEX SGG coupling, size 80,  
Total length LG = 103 mm
- Bore ØD1 30 H7
- Bore ØD2 38 h7

Article No.: 2LC0591-2AB99-0AB0 L0S+M0V

<sup>1)</sup> To identify complete item numbers specifying the available finish boring options and – if necessary – further order options, please use our configurators on [flender.com](http://flender.com).

➤ For online configuration on [flender.com](http://flender.com), click on the item no.

# TYPE SGG-A

Miniature series with axially plug-in clamping hub

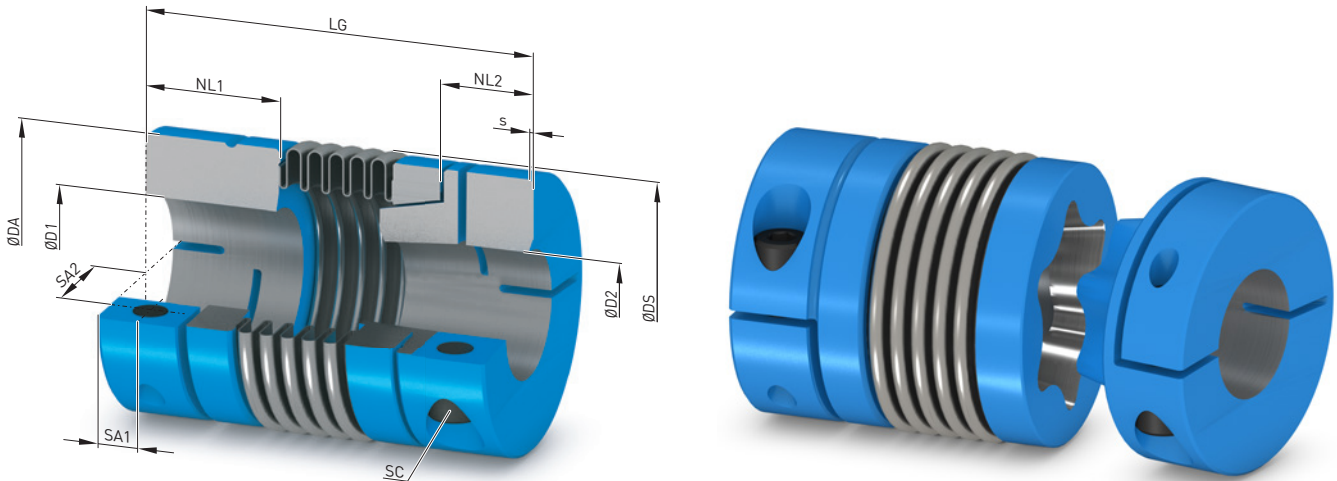

Size	Rated torque	Maximum speed	Dimensions in mm											Screw DIN EN ISO 4762		Moment of inertia	Article No. <sup>1)</sup>	Weight
	$T_{KN}$ Nm	$n_{Kmax}$ rpm	DA	DS	D1, D2 H7 min.	D1 max.	D2 max.	NL1	NL2	LG	s Preten.	SA1	SA2	SC	$T_A$ Nm	J gcm <sup>2</sup>		m
<b>Hub material aluminum</b>																		
45	4,5	15000	32,5	34	5	16	14	13	13	48 56	0,7	4,5	12	M4	3,5	88	2LC0590-6AE99-0AA0	58
																95	2LC0590-6AE99-0AB0	68
100	10	15000	40	41,5	6	22	18	14	13	54 64	1	4,7	15,5	M4	4,5	230	2LC0590-7AE99-0AA0	90
																260	2LC0590-7AE99-0AB0	120

## Notes

- The variant with axially plug-in clamping hub is designed for simple blind or bell housing assembly.
- The maximum torques that can be transmitted by the clamping connection are listed in the table on **page 14/9**.
- A keyway according to DIN 6885-1 can be selected additionally as an option.
- Weights and mass moments of inertia apply to maximum bore diameters.

## Ordering example

- SIPEX SGG-A coupling, size 45  
Total length LG = 48 mm
- Bore ØD1 14 H7
- Bore ØD2 12 H7

Article No.: 2LC0590-6AE99-0AA0 LOH+M0G

<sup>1)</sup> To identify complete item numbers specifying the available finish boring options and – if necessary – further order options, please use our configurators on [flender.com](http://flender.com).

➤ For online configuration on [flender.com](http://flender.com), click on the item no.



# TYPE SGG-A

Standard series with axially plug-in clamping hub

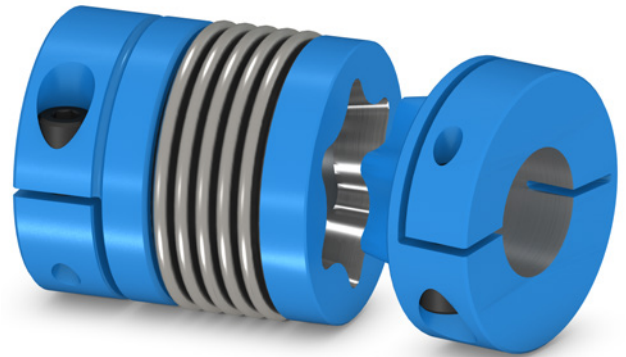
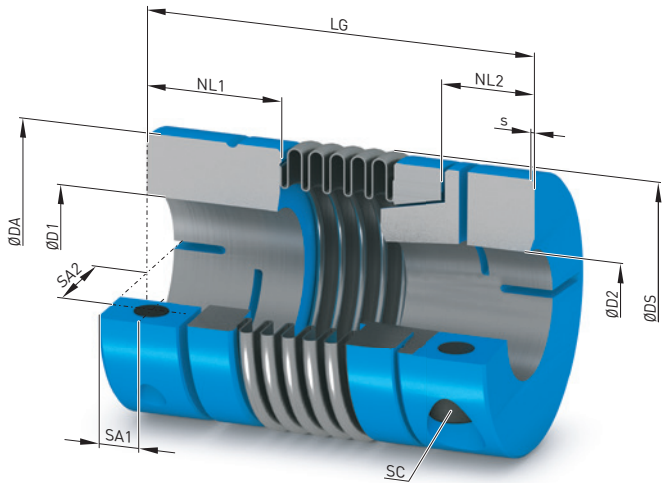

Size	Rated torque $T_{KN}$ Nm	Maximum speed $n_{Kmax}$ rpm	Dimensions in mm											Screw DIN EN ISO 4762		Moment of inertia $J$ 10 <sup>-3</sup> ·kgm <sup>2</sup>	Article No. <sup>1)</sup>	Weight $m$ kg	
			DA	DS	D1, D2 H7 min.	D1 max.	D2 max.	NL1	NL2	LG	s Preten.	SA1	SA2	SC	$T_A$ Nm				
<b>Hub material aluminum</b>																			
18	18	12800	45	47	8	25	21	20,5	13	$\frac{62}{69}$	0,5-1,0	5,7	17,5	M5	8	0,04 0,05	2LC0590-8AE99-0AA0 2LC0590-8AE99-0AB0	0,12 0,15	
30	30	10300	54	56	10	30	23	24,5	19,5	$\frac{70}{78}$	0,5-1,0	7,5	20	M6	15	0,12 0,13	2LC0591-0AE99-0AA0 2LC0591-0AE99-0AB0	0,27 0,28	
60	60	8700	65	67	12	35	30	29	25,5	$\frac{84}{94}$	0,5-1,5	10	24	M8	40	0,33 0,34	2LC0591-1AE99-0AA0 2LC0591-1AE99-0AB0	0,5 0,52	
80	80	6900	79	84	14	42	38	34	26	$\frac{95}{105}$	0,5-1,5	11,8	28	M10	72	0,78 0,84	2LC0591-1AE99-0AA0 2LC0591-2AE99-0AB0	0,79 0,83	
150	150	6900	79	84	14	42	38	34	24	$\frac{95}{105}$	0,5-1,5	11,8	28	M10	84	0,78 1,05	2LC0591-3AE99-0AA0 2LC0591-3AE99-0AB0	0,79 0,96	
200	200	6400	90	93	20	45	40	38	31,5	$\frac{105}{117}$	0,5-1,5	12,5	31,5	M12	125	1,47 1,58	2LC0591-4AE99-0AA0 2LC0591-4AE99-0AB0	1,16 1,25	
300	300	6000	109	110	24	50	45	38	32	$\frac{110}{121}$	0,5-1,5	13	35	M12	145	3,2 3,3	2LC0591-5AE99-0AA0 2LC0591-5AE99-0AB0	1,8 1,85	
500	500	5000	119	122	35	60	60	41,5	39	$\frac{126}{137}$	0,5-2,0	15	42	M14	190	5 5,2	2LC0591-6AE99-0AA0 2LC0591-6AE99-0AB0	2,25 2,3	

## Notes

- The variant with axially plug-in clamping hub is designed for simple blind or bell housing assembly.
- The maximum torques that can be transmitted by the clamping connection are listed in the table on [page 14/9](#).
- A keyway according to DIN 6885-1 can be selected additionally as an option.
- Weights and mass moments of inertia apply to maximum bore diameters.

## Ordering example

- SIPEX SGG-A coupling, size 80  
Total length LG = 95 mm

- Bore ØD1 30 H7
- Bore ØD2 38 H7

Article No.: 2LC0591-2AE99-0AA0 L0S+M0V

<sup>1)</sup> To identify complete item numbers specifying the available finish boring options and – if necessary – further order options, please use our configurators on [flender.com](http://flender.com).

➤ For online configuration on [flender.com](http://flender.com), click on the item no.

# TYPE SHH

Miniature series with half-shell clamping hub

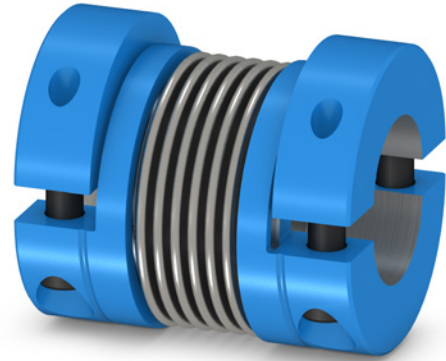
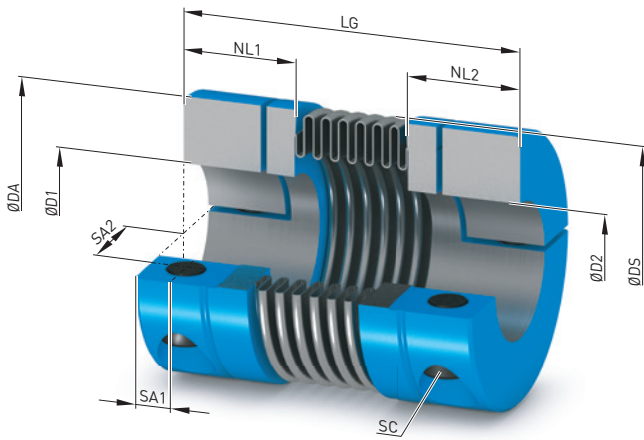

Size	Rated torque $T_{KN}$ Nm	Maximum speed $n_{Kmax}$ rpm	Dimensions in mm								Screw DIN EN ISO 4762		Moment of inertia $J$ gcm <sup>2</sup>	Article No. <sup>1)</sup>	Weight $m$ g		
			DA	DS	D1, D2 H7 min.   max.	NL1/ NL2	LG	SA1	SA2	SC	$T_A$ Nm						
<b>Hub material aluminum</b>																	
5	0,5	15000	15,5	17,5	3	7	6,8	21	2,4	5,2	M2	0,5	1,4	2LC0590-2AC99-0AA0	4		
								25					2,6			2LC0590-2AC99-0AB0	7,3
								28					2,8			2LC0590-2AC99-0AC0	7,7
10	1	15000	15,5	17,5	3	7	6,8	23	2,4	5,2	M2	0,5	3	2LC0590-3AC99-0AA0	8,2		
								27					3,2			2LC0590-3AC99-0AB0	8,8
								31					3,4			2LC0590-3AC99-0AC0	9,3
15	1,5	15000	20	21	3	10	8,5	27	3	7	M2,5	0,9	8,4	2LC0590-4AC99-0AA0	13,7		
								31					8,5			2LC0590-4AC99-0AB0	13,8
								32					25			2LC0590-5AC99-0AA0	25
20	2	15000	25	27	3	12,5	11	38	3,5	9	M3	2	28	2LC0590-5AC99-0AB0	29		
								42					32			2LC0590-5AC99-0AC0	32
								42					82			2LC0590-6AC99-0AA0	50
45	4,5	15000	32,5	34	6	16	13	50	4,5	11,5	M4	3,5	113	2LC0590-6AC99-0AB0	68		
								48					196			2LC0590-7AC99-0AA0	75
								57					300			2LC0590-7AC99-0AB0	111

14

### Notes

- It is possible to radially assemble and dismantle the hub version with half-shells without moving the connected units.
- The maximum torques that can be transmitted by the clamping connection are listed in the table on [page 14/9](#).
- A keyway according to DIN 6885-1 can be selected additionally as an option.
- Weights and mass moments of inertia apply to maximum bore diameters.

### Ordering example

- SIPEX SHH coupling, size 45  
Total length LG = 42 mm
- Bore ØD1 12 H7
- Bore ØD2 16 H7

Article No.: 2LC0590-6AC99-0AA0 LG+M0J

<sup>1)</sup> To identify complete item numbers specifying the available finish boring options and – if necessary – further order options, please use our configurators on [flender.com](http://flender.com).

↗ For online configuration on [flender.com](http://flender.com), click on the item no.

# TYPE SHH

Standard series with half-shell clamping hub

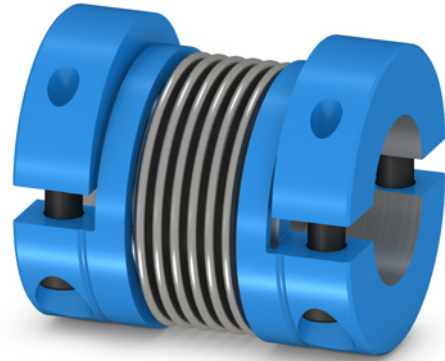
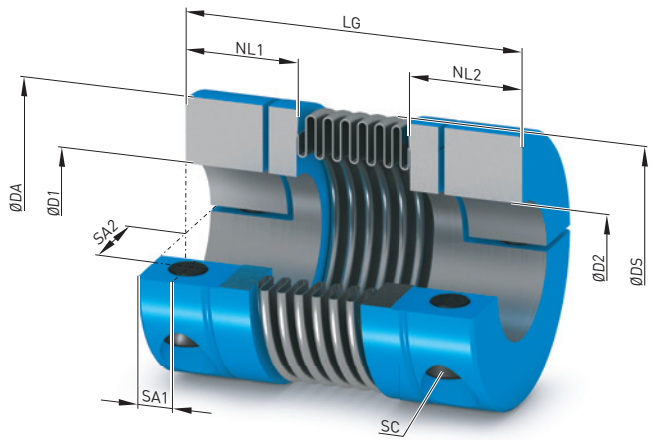

Size	Rated torque $T_{KN}$ Nm	Maximum speed $n_{Kmax}$ rpm	Dimensions in mm								Screw DIN EN ISO 4762		Moment of inertia $J$ $10^{-3} \cdot \text{kgm}^2$	Article No. <sup>1)</sup>	Weight $m$ kg
			DA	DS	D1, D2 H7 min.   max.	NL1/ NL2	LG	SA1	SA2	SC	$T_A$ Nm				
<b>Hub material aluminum</b>															
18	18	12800	45	48	8	25	20,5	$\frac{63}{72}$	5,7	17,5	M5	8	0,05 0,05	2LC0590-8AC99-0AA0 2LC0590-8AC99-0AB0	0,15 0,16
30	30	10300	54	56	10	30	24,5	$\frac{65}{74}$	7,5	20	M6	15	0,11 0,12	2LC0591-0AC99-0AA0 2LC0591-0AC99-0AB0	0,23 0,25
60	60	8700	65	67	12	35	29	$\frac{79}{89}$	10	24	M8	40	0,32 0,33	2LC0591-1AC99-0AA0 2LC0591-1AC99-0AB0	0,46 0,49
80	80	6900	79	84	14	42	34	$\frac{91}{102}$	11,8	28	M10	72	0,83 0,89	2LC0591-2AC99-0AA0 2LC0591-2AC99-0AB0	0,81 0,85
150	150	6900	79	84	14	42	34	$\frac{91}{102}$	11,8	28	M10	84	0,83 0,89	2LC0591-3AC99-0AA0 2LC0591-3AC99-0AB0	0,81 0,85
200	200	6400	90	93	20	45	38	$\frac{101}{113}$	12,5	31,5	M12	125	1,45 1,55	2LC0591-4AC99-0AA0 2LC0591-4AC99-0AB0	1,14 1,21
300	300	6000	109	110	24	50	38	$\frac{103}{116}$	13	35	M12	145	3,04 3,15	2LC0591-5AC99-0AA0 2LC0591-5AC99-0AB0	1,69 1,73
500	500	5000	119	122	35	60	41,5	$\frac{111}{123}$	14	42	M14	190	4,59 4,77	2LC0591-6AC99-0AA0 2LC0591-6AC99-0AB0	2,05 2,11

## Notes

- It is possible to radially assemble and dismantle the hub version with half-shells without moving the connected units.
- The maximum torques that can be transmitted by the clamping connection are listed in the table on [page 14/9](#).
- A keyway according to DIN 6885-1 can be selected additionally as an option.
- Weights and mass moments of inertia apply to maximum bore diameters.

## Ordering example

- SIPEX SHH coupling, size 80  
Total length LG = 91 mm
- Bore ØD1 30 H7
- Bore ØD2 38 H7

Article No.: 2LC0591-2AC99-0AA0-Z L0S+M0V

<sup>1)</sup> To identify complete item numbers specifying the available finish boring options and – if necessary – further order options, please use our configurators on [flender.com](http://flender.com).

➤ For online configuration on [flender.com](http://flender.com), click on the item no.

# TYPE SKK

Miniature series with external taper

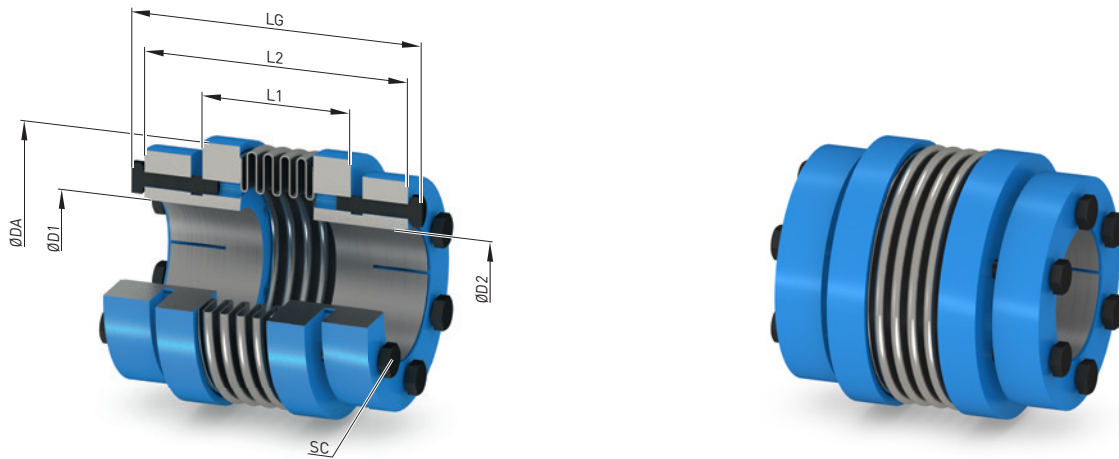

Size	Rated torque $T_{KN}$ Nm	Maximum speed $n_{Kmax}$ rpm	Dimensions in mm						Screw DIN EN ISO 4017		Moment of inertia $J$ gcm <sup>2</sup>	➤ Article No. <sup>1)</sup>	Weight $m$ g
			DA	D1, D2 H7 min.   max.	L1	L2	LG	SC	$T_A$ Nm				
<b>Hub material steel</b>													
45	4,5	15000	32	6	10	25	37	42	M3	1,3	64	2LC0590-6AF99-0AA0	49
						33	45	50			95		2LC0590-6AF99-0AB0
100	10	15000	40	8	14	33	45	48	M3	1,3	166	2LC0590-7AF99-0AA0	77
						38	52	57			270		2LC0590-7AF99-0AB0

## Notes

- The clamping hubs with external taper are the ideal solution for high-speed and highly dynamic applications.
- The maximum torques that can be transmitted by the clamping connection are listed in the table on [page 14/9](#).
- Weights and mass moments of inertia apply to maximum bore diameters.

## Ordering example

- SIPEX SKK coupling, size 45  
Total length LG = 42 mm
- Bore ØD1 10 H7
- Bore ØD2 8 H7

Article No.: 2LC0590-6AF99-0AA0 L0E+M0C

<sup>1)</sup> To identify complete item numbers specifying the available finish boring options and – if necessary – further order options, please use our configurators on [flender.com](http://flender.com).

➤ For online configuration on [flender.com](http://flender.com), click on the item no.

# TYPE SKK

Standard series with external taper

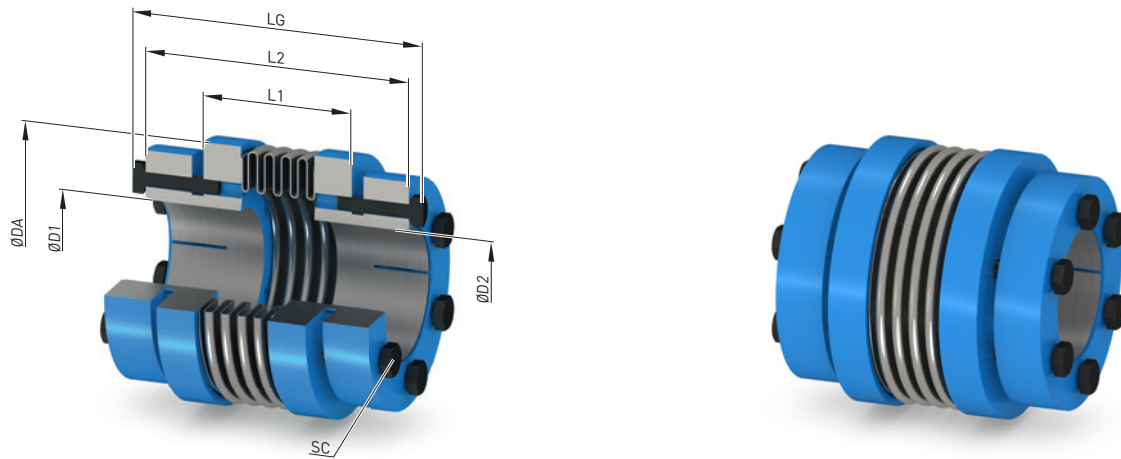

Size	Rated torque $T_{KN}$ Nm	Maximum speed $n_{Kmax}$ rpm	Dimensions in mm			L1	L2	LG	Screw DIN EN ISO 4017		Moment of inertia $J$ 10 <sup>-3</sup> ·kgm <sup>2</sup>	Article No. <sup>1)</sup>	Weight $m$ kg
			DA	D1, D2 H7 min.   max.	SC				$T_A$ Nm				
<b>Hub material steel</b>													
18	18	12800	47	8	15	37	57	65	M5	5,9	0,07	2LC0590-8AF99-0AA0	0,3
						45	65	73			0,08		
30	30	10300	56	12	20	30	52	60	M5	5,9	0,12	2LC0591-0AF99-0AA0	0,43
						38	60	68			0,17		
60	60	8700	64	15	32	34	70	79	M6	8,7	0,57	2LC0591-1AF99-0AA0	0,89
						44	80	89			0,57		
80	80	6900	82	20	35	48	88	97	M6	15	1,42	2LC0591-2AF99-0AA0	1,63
						60	100	109			1,44		
150	150	6900	82	20	35	48	88	97	M6	15	1,42	2LC0591-3AF99-0AA0	1,63
						60	100	109			1,44		
200	200	6400	90	20	42	50	89	98	M6	15	1,5	2LC0591-4AF99-0AA0	1,8
						62	101	110			1,6		
300	300	6000	110	25	50	55	99	110	M8	25	4,9	2LC0591-5AF99-0AA0	3,05
						65	109	120			5		
500	500	5000	122	35	55	60	113	125	M8	36	8,3	2LC0591-6AF99-0AA0	4,39
						70	123	135			8,5		
800	800	3700	157	50	70	92	166	182	M12	85	36	2LC0591-7AF99-0AA0	10,9
1400	1400	3700	157	50	70	92	166	182	M12	115	36	2LC0591-8AF99-0AA0	10,9
3000	3000	2800	157	55	75	92	166	182	M12	125	36	2LC0592-0AF99-0AA0	10,9
5000	5000	2800	210	60	90	140	219	240	M16	210	165	2LC0592-1AF99-0AA0	30,4

## Notes

- The clamping hubs with external taper are the ideal solution for high-speed and highly dynamic applications.
- The maximum torques that can be transmitted by the clamping connection are listed in the table on [page 14/9](#).
- Weights and mass moments of inertia apply to maximum bore diameters.

## Ordering example

- SIPEX SKK coupling, size 80  
Total length LG = 97 mm
- Bore ØD1 30 H7
- Bore ØD2 35 H7

Article No.: 2LC0591-2AF99-0AA0 L0S+M0U

<sup>1)</sup> To identify complete item numbers specifying the available finish boring options and – if necessary – further order options, please use our configurators on [flender.com](http://flender.com).

➤ For online configuration on [flender.com](http://flender.com), click on the item no.

# TYPE SII

Standard series with internal taper

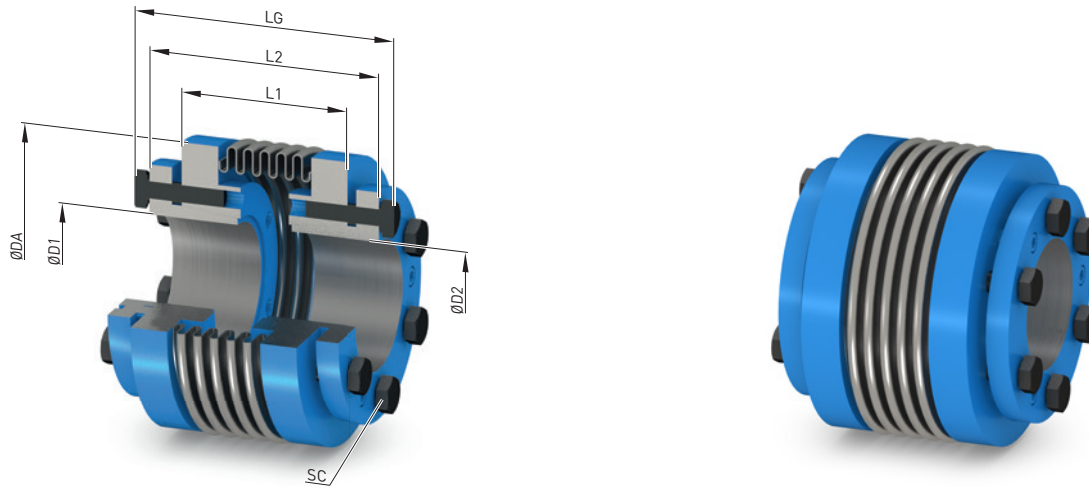

Size	Rated torque $T_{KN}$ Nm	Maximum speed $n_{Kmax}$ rpm	Dimensions in mm						Screw DIN EN ISO 4017		Moment of inertia $J$ $10^{-3} \cdot \text{kgm}^2$	Article No. <sup>1)</sup>	Weight $m$ kg
			DA	D1, D2 H7 min.   max.	LG	L1	L2	SC	$T_A$ Nm				
<b>Hub material steel</b>													
18	18	12800	47	10	17	62	42	57	M4	4	0,05	2LC0590-8AG99-0AA0	0,2
						70	50	64					2LC0590-8AG99-0AB0
30	30	10300	56	12	20	53	34	47	M4	4,5	0,08	2LC0591-0AG99-0AA0	0,24
						61	42	55			2LC0591-0AG99-0AB0	0,27	
60	60	8700	64	15	25	62	34	53	M6	8,5	0,22	2LC0591-1AG99-0AA0	0,46
						73	45	64			2LC0591-1AG99-0AB0	0,48	
80	80	6900	82	20	35	79	50	70	M6	10	0,65	2LC0591-2AG99-0AA0	0,82
						90	60	81			2LC0591-2AG99-0AB0	0,87	
150	150	6900	82	20	35	79	50	70	M6	15	0,65	2LC0591-3AG99-0AA0	0,82
						90	60	81			2LC0591-3AG99-0AB0	0,87	
200	200	6400	90	20	40	79	50	70	M6	15	0,85	2LC0591-4AG99-0AA0	0,92
						92	63	84			2LC0591-4AG99-0AB0	0,94	
300	300	6000	110	25	50	90	53	78	M8	17	2,58	2LC0591-5AG99-0AA0	1,82
						103	65	91			2LC0591-5AG99-0AB0	1,86	
500	500	5000	122	35	55	103	65	91	M8	25	4,2	2LC0591-6AG99-0AA0	2,34
						113	71	101			2LC0591-6AG99-0AB0	2,4	
800	800	3700	157	50	70	170	108	148	M16	45	28,4	2LC0591-7AG99-0AA0	9,69
1400	1400	3700	157	50	70	170	108	148	M16	80	28,4	2LC0591-8AG99-0AA0	9,69
3000	3000	2800	157	55	75	170	108	148	M16	115	32,5	2LC0592-0AG99-0AA0	10,2
5000	5000	2800	210	60	90	202	140	180	M16	210	115	2LC0592-1AG99-0AA0	20,9

## Notes

- The clamping hubs with internal taper are the ideal solution for high-speed and highly dynamic applications. These couplings require less installation space than type SKK.
- The maximum torques that can be transmitted by the clamping connection are listed in the table on [page 14/9](#).
- Weights and mass moments of inertia apply to maximum bore diameters.

## Ordering example

- SIPEX SII coupling, size 80  
Total length LG = 79 mm
- Bore ØD1 30 H7
- Bore ØD2 35 H7

Article No.: 2LC0591-2AG99-0AA0 L0S+M0U

<sup>1)</sup> To identify complete item numbers specifying the available finish boring options and – if necessary – further order options, please use our configurators on [flender.com](http://flender.com).

↗ For online configuration on [flender.com](http://flender.com), click on the item no.

# TYPE SHH-W

Standard series, drive shaft with half-shell clamping hubs

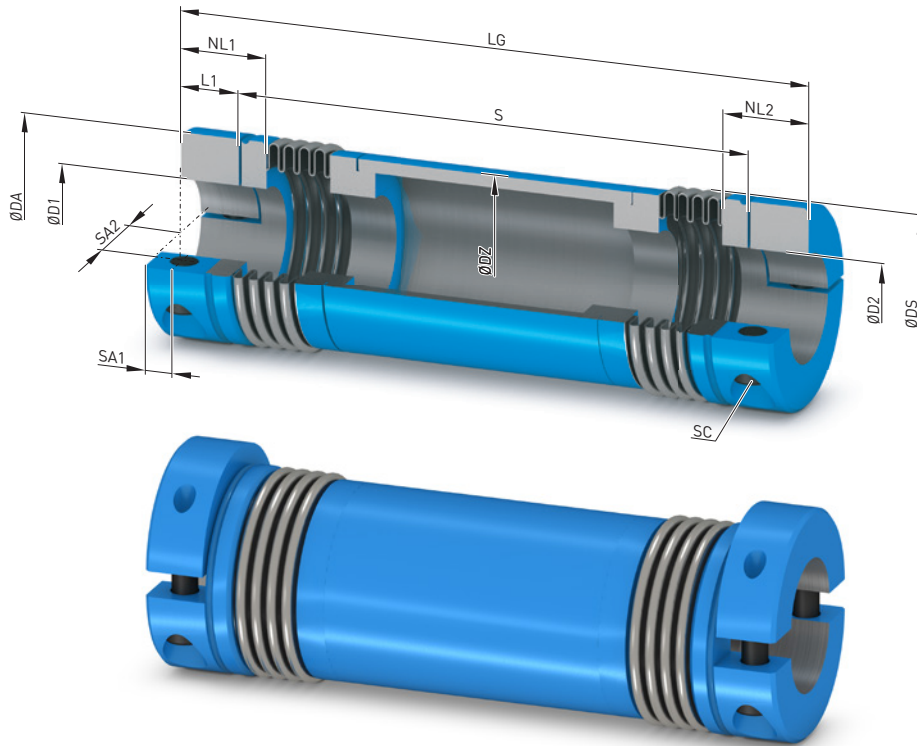

Size	Rated torque $T_{KN}$ Nm	Maximum speed $n_{Kmax}$ rpm	Dimensions in mm										Screw DIN EN ISO 4762 $T_A$ Nm	Moment of inertia <sup>2)</sup> $J$ 10 <sup>-3</sup> · kgm <sup>2</sup>	Article No. <sup>1)</sup>	Weight $m$ kg		
			DA	DS	D1, D2 H7		DZ	NL1/ NL2	L1	LG		SA1					SA2	
					min.	max.				min.	max.							
<b>Hub material aluminum</b>																		
18	18	1500	45	48	8	25	40	20,5	13,5	132	3000	5,7	17,5	M5	10	0,51	2LC0590-8AH99-0AZ0	1,63
30	30	1500	54	56	10	30	50	24,5	17	130	3000	7,5	20	M6	17	1,13	2LC0591-0AH99-0AZ0	2,29
60	60	1500	65	67	12	35	60	29	22	165	3000	10	24	M8	42	2,42	2LC0591-1AH99-0AZ0	3,34
150	150	1500	79	84	14	42	75	34	24	196	3000	11,8	28	M10	83	5,77	2LC0591-3AH99-0AZ0	5,1
200	200	1500	90	93	20	45	90	38	28	218	3000	12,5	31,5	M12	145	9,53	2LC0591-4AH99-0AZ0	5,9
300	300	1500	109	110	24	60	100	38	28	220	3000	13	39	M12	145	14,6	2LC0591-5AH99-0AZ0	7,1
500	500	1500	119	122	35	60	110	41,5	31,5	250	3000	14,3	42	M14	230	18,6	2LC0591-6AH99-0AZ0	7,3

## Notes

- It is possible to radially assemble and dismantle the hub version with half-shells without moving the connected units. It must be noted that the total length LG is obtained with shaft distance  $S + 2 \times L1$ .
- The intermediate tubes in the standard version are made of aluminum. Tubes made of carbon-fiber-reinforced plastic (CFRP) are also available as an option.
- Weights and mass moments of inertia apply to maximum bore diameters and a shaft distanced  $S = 1000$  mm.
- Drive shafts with slotted clamping hubs are available as an alternative (type SGG-W).

## Ordering example

- SIPEX SHH-W coupling, size 60  
Shaft distance  $S = 1000$  mm  
Total length  $LG = 1044$  mm
- Bore  $\text{ØD1 } 24$  H7
- Bore  $\text{ØD2 } 28$  H7

Article No.: 2LC0591-1AH99-0AZ0 L0P+M0R+Q0Y  
Plain text for Q3Y:  $S = 1000$  mm

<sup>1)</sup> To identify complete item numbers specifying the available finish boring options and – if necessary – further order options, please use our configurators on [fletcher.com](http://fletcher.com).

<sup>2)</sup> for DBSE = 1000 mm

➤ For online configuration on [fletcher.com](http://fletcher.com), click on the item no.





# BACKLASH-FREE COUPLINGS

## BIPEX-S SERIES

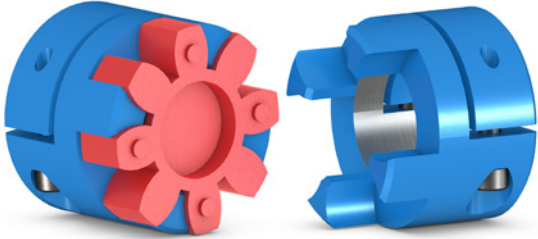

<b>General</b>	<b>15/2</b>
Benefits	15/2
Application	15/3
Design and configurations	15/3
Preliminary dimensioning	15/5
Key to formula symbols	15/6
Technical information	15/6
Transmissible torques of the different clamping connections	15/8
<hr/>	
<b>Type BNN</b>	
Hubs with set screws	<b>15/10</b>
<hr/>	
<b>Type BGG</b>	
Standard clamping hubs	<b>15/12</b>
<hr/>	
<b>Type BCC</b>	
Clamping hubs in compact design	<b>15/14</b>
<hr/>	
<b>Type BHH</b>	
Half-shell clamping hub	<b>15/16</b>
<hr/>	
<b>Type BKK</b>	
Clamping hubs with external taper	<b>15/17</b>
<hr/>	
<b>Type BCS</b>	
Compact clamping hubs and expanding hub	<b>15/18</b>
<hr/>	
<b>Type BHH-W</b>	
Drive shaft with half-shell clamping hubs	<b>15/19</b>
<hr/>	

# GENERAL

BIPEX-S couplings are torsionally flexible and are free of backlash in the pretensioned state. They are characterized by their compact design and high power density. BIPEX-S couplings connect machine shafts and compensate for shaft misalignment that can occur during assembly or operation. The damping properties of the couplings can be varied by the use of cam rings made of elastomer of various degrees of hardness.

BIPEX-S couplings are suitable for all drive applications which require a coupling that offers positioning accuracy and vibration damping.

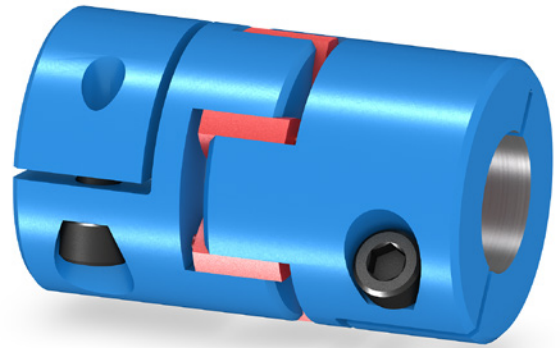

## Benefits

BIPEX-S couplings are suitable for mounting horizontally, vertically or in any desired position. The coupling parts can be arranged as required on the shaft ends to be connected. The coupling can be axially plugged in.

The cam ring is pretensioned and is therefore assembled without backlash. The cams attached to the cam ring allow the coupling to compensate shaft misalignment, and also provide electrical isolation since they prevent contact between the two hub parts.

BIPEX-S couplings are fail-safe. When the cam ring is worn, the claws of the coupling hubs provide for fail-safe operation.

Available in 4 different Shore hardness grades, the cam rings allow to select the optimum degree of rigidity for any application.



## Application

BIPEX-S couplings within the standard catalog range are available in 10 sizes with torque ratings ranging from 0.5 to 655 Nm. The coupling is suitable for ambient temperatures of between -30 °C and +90 °C. Cam rings with alternative hardness grades can be supplied for ambient temperatures down to -50 °C or up to +120 °C.

BIPEX-S couplings are ideal for use in servo drives, linear axes or rotary encoders of the type typically deployed in machine tools, packaging machines or printing presses.

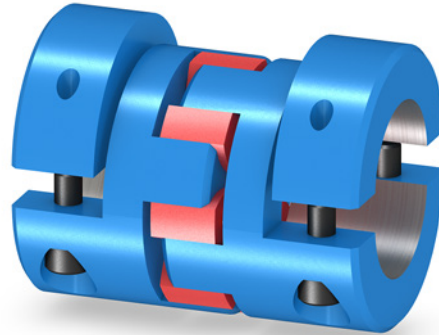

## Design and configurations

BIPEX-S couplings each comprise two hub parts connected by a cam ring made of polyurethane (PU).

The couplings can be axially plugged in during assembly. The hubs can be coupled to the shafts by many different methods including set screws, key joint, slotted clamping hubs, half-shell hubs, clamping hubs or expanding hubs.

BIPEX-S couplings are positive-locking and torsionally flexible thanks to the polyurethane cam ring. Misalignment between the connected shafts deforms the cam ring.

## Coupling materials

Hubs	Up to size 38 aluminum Sizes 42 and 48 steel
Cam ring	PU 80 ShoreA -50 °C to +80 °C PU 92 ShoreA -40 °C to +90 °C <b>PU 98 ShoreA</b> -30 °C to +90 °C (standard ring) PU 64 ShoreD -50 °C to +120 °C

The coupling types can be combined from the available range of hub versions and different elastomer grades.

## Hub versions

Hub	Description
N	Hub with set screw
G	Slotted clamping hub
C	Slotted clamping hub, compact
H	Half-shell clamping hub
K	Clamping hub with external taper
S	Expanding hub

The N version has a keyway as standard. Versions G, C and H are optionally available with keyway.

The fitting tolerance of the coupled shaft ends should be g6 or h7.

# GENERAL

## BIPEX-S coupling versions

Type	Description
BNN <sup>1)</sup>	Hub with set screw on both sides
BGG <sup>1)</sup>	Clamping hub on both sides
BCC <sup>1)</sup>	Compact clamping hub on both sides
BHH <sup>1)</sup>	Half-shell clamping hubs on both sides
BKK <sup>1)</sup>	Clamping hub with external taper on both sides
BHH-W <sup>1)</sup>	Drive shaft with half-shell clamping hub

Type	Description	
	Hub 1	Hub 2
BCS <sup>1)</sup>	Clamping hub	Expanding hub
BNG	Set screw	Clamping hub
BNC	Set screw	Clamping hub compact
BNH	Set screw	Half-shell clamping hub
BNK	Set screw	External taper
BGC	Clamping hub	Clamping hub compact
BGH	Clamping hub	Half-shell clamping hub
BGK	Clamping hub	External taper
BGS	Clamping hub	Expanding hub
BCH	Clamping hub compact	Half-shell clamping hub
BCK	Clamping hub compact	External taper
BHK	Half-shell clamping hub	External taper
BHS	Expanding hub	External taper
BKS	Expanding hub	External taper

## Cam rings

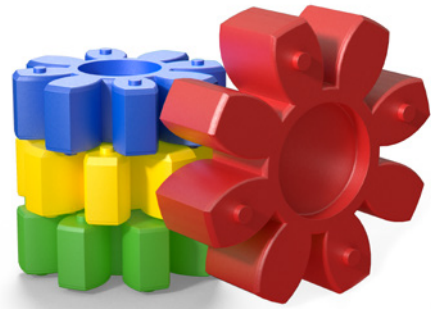

98 ShoreA (red)  
 92 ShoreA (yellow)  
 80 ShoreA (blue)  
 64 ShoreD (green)

## Hub variants

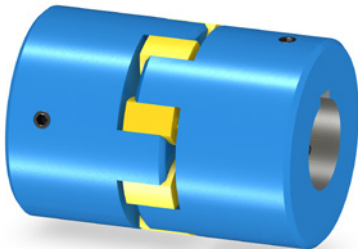

Set screw

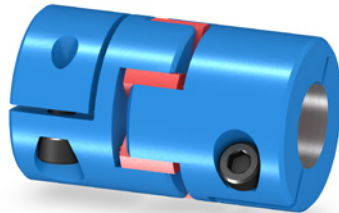

Clamping hub

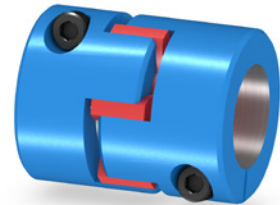

Clamping hub compact

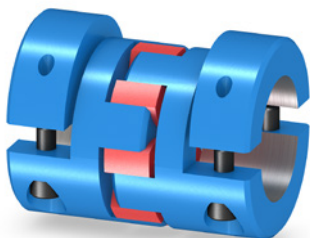

Half-shell clamping hub

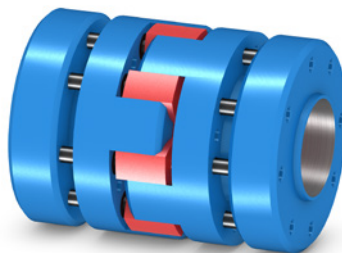

External taper

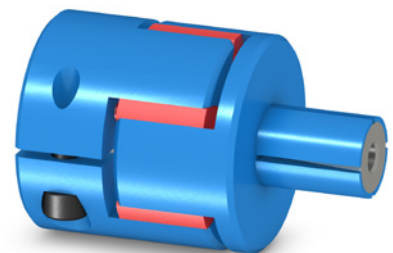

Expanding hub

<sup>1)</sup> Standard version

## Preliminary dimensioning

### Dimensioning according to torque

The coupling must be dimensioned such that the rated torque of the drive including service factors does not exceed the rated torque of the coupling:

$$T_{KN} \geq T_N \cdot FB \cdot FT$$

Torque characteristic	Service factor FB
Uniform	1.25
Non uniform	1.5
Rough	2

In order to increase the torsional rigidity and therefore minimize the torsional backlash, it is possible to apply significantly higher service factors for main spindle or positioning drives.

Temperature range	Temperature factor FT
-30 °C to +30 °C	1
to +60 °C	1.4
to +80 °C	1.8
to +100 °C	2
to +120 °C	2.8

Note:

Please note the permissible temperature ranges of different cam rings.

Starts per hour	Startup factor FA
< 125	1
125 to 250	1.3
250 to 500	1.6
500 to 1000	1.8
> 1000	2

### Checking the peak torques

The coupling size selected during the preliminary dimensioning process must also be suitable with respect to peak torques at the drive and load ends:

$$T_{KN} \geq T_S \cdot FB \cdot FT$$

$$T_S = T_{AS} \cdot \frac{J_L}{J_A + J_L} \cdot FA \quad \text{or} \quad T_S = T_{LS} \cdot \frac{J_A}{J_A + J_L} \cdot FA$$

### Checking the maximum speed

For all load situations  $n_{Kmax} > n_{max}$

### Checking the permitted shaft misalignment

The actual shaft misalignment must be less than the permitted shaft misalignment for all load situations.

### Checking the shaft-hub connection

In the case of clamping connections without feather key, it must be ensured that the transmissible torque of the hub connection is greater than the peak torque at the coupling.

# GENERAL

## Key to formula symbols

Name	Formula symbol	Unit	Explanation
Rated coupling torque	$T_{KN}$	Nm	Torque which can be transmitted as static torque by the coupling over the period of use
Coupling overload torque	$T_{KOL}$	Nm	Torque which can be transmitted very rarely as maximum torque by the coupling.
Peak torque at drive end	$T_{AS}$	Nm	Peak torque during non-periodic torque surges at drive end
Peak torque at load end	$T_{LS}$	Nm	Peak torque during non-periodic torque surges at load end
Peak torque	$T_S$	Nm	Peak torque at the coupling
Service factor	FB		Factor that expresses the real coupling load as a ratio of the nominal coupling load
Temperature factor	FT		Factor that takes into account the reduction in strength of flexible rubber materials at higher temperatures
Startup factor	FA		Factor that takes into account additional loading as a function of starting frequency
Moment of inertia of drive end	$J_A$	kgm <sup>2</sup>	Sum of the moments of inertia at the drive end referred to the coupling speed
Moment of inertia of load end	$J_L$	kgm <sup>2</sup>	Sum of the moments of inertia at the load end referred to the coupling speed
Torsion angle	$\varphi$	°	Torsion angle of the coupling under torsional load
Torsional stiffness, dynamic	$C_{Tdyn}$	Nm/rad	Dynamic torsional stiffness of the coupling
Axial stiffness	$C_a$	N/mm	Axial stiffness of the coupling
Radial stiffness	$C_r$	N/mm	Radial stiffness of the coupling
Rated speed	$n_N$	rpm	Coupling speed
Maximum coupling speed	$n_{k\ max}$	rpm	Maximum permissible coupling speed
Axial misalignment	$\Delta K_a$	mm	Axial misalignment of the coupling halves
Radial misalignment	$\Delta K_r$	mm	Radial misalignment of the coupling halves
Angular misalignment	$\Delta K_w$	°	Angular misalignment of the coupling halves

## Technical information

### Torsional stiffness and damping

The values stated in the table apply to a capacity utilization of 50 %, an excitation amplitude of 10 %  $T_{KN}$  with a frequency of 10 Hz and an ambient temperature of 20 °C. The dynamic torsional stiffness is load-dependent and increases in proportion to capacity utilization.

The relative damping coefficient is  
 **$\psi = 0,8$  for 98, 92 and 80 ShoreA**  
 **$\psi = 0,75$  for 64 ShoreD.**

$T_{KOL}$  is the torque which can be transmitted very rarely as maximum torque by the coupling.

15

### Zulässiger Wellenversatz

The permitted shaft misalignments  $\Delta K_a$ ,  $\Delta K_r$  and  $\Delta K_w$  are maximum values and must not occur simultaneously. The following formula can be used to roughly calculate whether combinations of misalignments are permissible:

$$\frac{\Delta K_{r\ act}}{\Delta K_r} + \frac{\Delta K_{a\ act}}{\Delta K_a} + \frac{\Delta K_{w\ act}}{\Delta K_w} < 1$$

Cam rings										
Size	Rated torque	Maximum torque	Maximum speed			Torsional stiffness	Radial stiffness	Permitted shaft misalignment		
	$T_{KN}$ Nm		$T_{KOL}$ Nm	Type BNN $n_{k\ max}$ rpm	BGG, BHH, BCC, BCS $n_{k\ max}$ rpm			BKK $n_{k\ max}$ rpm	$C_{Tdyn}$ Nm/rad	$C_T$ Nm/mm
Polyurethane cam rings 80 ShoreA										
5	0.3	0.6	47500	38000	–	10	82	0.4	0.12	1.1
7	0.7	1.4	35000	26000	–	26	114	0.6	0.15	1.1
9	1.8	3.6	24000	18000	–	52	125	0.8	0.19	1.1
14	4	8	16000	12000	25000	180	153	1	0.21	1.1
19	5	10	12000	9500	18500	1030	582	1.2	0.15	1.1
Polyurethane cam rings 92 ShoreA										
5	0.5	1	47500	38000	–	16	154	0.4	0.06	1
7	1.2	2.4	35000	26000	–	43	219	0.6	0.1	1
9	3	6	24000	18000	–	95	262	0.8	0.13	1
14	7.5	15	16000	12000	25000	344	335	1	0.15	1
19	10	20	12000	9500	18500	1720	1125	1.2	0.1	1
24	35	70	8700	7000	13900	4300	1490	1.4	0.14	1
28	95	190	7400	6000	11800	6880	1785	1.5	0.15	1
38	190	380	6000	4700	9600	13750	2350	1.8	0.17	1
42	265	530	5000	4000	8000	24300	2440	2	0.19	1
48	310	620	4600	3500	7100	18055	2590	2.1	0.23	1
Polyurethane cam rings 98 ShoreA										
5	0.9	1.8	47500	38000	–	25	296	0.4	0.04	0.9
7	2	4	35000	26000	–	69	421	0.6	0.06	0.9
9	5	10	24000	18000	–	155	518	0.8	0.08	0.9
14	12.5	25	16000	12000	25000	513	655	1	0.09	0.9
19	17	34	12000	9500	18500	2580	2010	1.2	0.06	0.9
24	60	120	8700	7000	13900	6190	2550	1.4	0.1	0.9
28	160	320	7400	6000	11800	10310	3210	1.5	0.11	0.9
38	325	650	6000	4700	9600	21490	4410	1.8	0.12	0.9
42	450	900	5000	4000	8000	48000	5575	2	0.14	0.9
48	525	1050	4600	3500	7100	55925	5950	2.1	0.16	0.9
Polyurethane cam rings 64 ShoreD										
7	2.4	4.8	35000	26000	–	103	630	0.6	0.04	0.8
9	6	12	24000	18000	–	224	769	0.8	0.05	0.8
14	16	32	16000	12000	25000	702	855	1	0.06	0.8
19	21	42	12000	9500	18500	3720	2950	1.2	0.04	0.8
24	75	150	8700	7000	13900	8930	3695	1.4	0.07	0.8
28	200	400	7400	6000	11800	13050	4350	1.5	0.08	0.8
38	405	810	6000	4700	9600	31620	6475	1.8	0.09	0.8
42	560	1120	5000	4000	8000	71700	7280	2	0.1	0.8
48	655	1310	4600	3500	7100	90500	8280	2.1	0.11	0.8

# GENERAL

## Transmissible torques of the different clamping connections

Size	Transmissible torque by clamping connection in Nm as a function of hub design and shaft diameter																										
	Bore diameter D1/D2 in mm																										
	2	3	4	6	8	10	12	14	16	19	20	22	24	25	28	30	32	35	38	40	42	45	48	50	55	60	
<b>Clamping hub (G-Hub)</b>																											
5	0.5	0.6	0.6	-	-	-	-	-	-	-	-	-	-	-	-	-	-	-	-	-	-	-	-	-	-	-	-
7	-	1	1.2	1.3	-	-	-	-	-	-	-	-	-	-	-	-	-	-	-	-	-	-	-	-	-	-	-
9	-	-	3.1	3.4	3.7	-	-	-	-	-	-	-	-	-	-	-	-	-	-	-	-	-	-	-	-	-	-
14	-	-	-	5.9	6.3	6.7	7.1	7.8	8	-	-	-	-	-	-	-	-	-	-	-	-	-	-	-	-	-	-
19	-	-	-	-	26	27.5	28.9	30	31.6	33.7	34.5	35.9	-	-	-	-	-	-	-	-	-	-	-	-	-	-	-
24	-	-	-	-	-	42	44	45.5	47	50	50.5	53	54	55	57	59	-	-	-	-	-	-	-	-	-	-	-
28	-	-	-	-	-	-	-	-	-	100	105	107	110	113	115	119	122	125	130	135	-	-	-	-	-	-	-
38	-	-	-	-	-	-	-	-	-	118	122	124	127	130	131	136	139	142	147	152	155	158	163	167	-	-	-
42	-	-	-	-	-	-	-	-	-	207	210	215	220	222	230	234	239	247	254	259	264	271	279	284	-	-	-
48	-	-	-	-	-	-	-	-	-	-	-	-	-	345	360	367	374	385	396	403	410	421	432	439	457	-	-
<b>Clamping hub compact (C-Hub)</b>																											
14	-	-	-	5.9	6.3	6.7	7.1	7.8	8	-	-	-	-	-	-	-	-	-	-	-	-	-	-	-	-	-	-
19	-	-	-	-	23	24	25	26	27.5	29	30	31	-	-	-	-	-	-	-	-	-	-	-	-	-	-	-
24	-	-	-	-	-	42	44	45.5	47	50	50.5	53	54	55	57	59	-	-	-	-	-	-	-	-	-	-	-
28	-	-	-	-	-	-	-	-	-	100	105	107	110	113	115	119	122	125	130	135	-	-	-	-	-	-	-
38	-	-	-	-	-	-	-	-	-	188	195	197	202	207	210	217	222	227	234	242	247	252	259	267	-	-	-
42	-	-	-	-	-	-	-	-	-	-	-	-	-	-	222	230	234	239	247	254	259	264	271	279	284	-	-
48	-	-	-	-	-	-	-	-	-	-	-	-	-	345	360	367	374	385	396	403	410	421	432	439	457	-	-
<b>Half-shell clamping hub (H-Hub)</b>																											
14	-	-	-	4	5.3	6.6	8	9.2	10.6	-	-	-	-	-	-	-	-	-	-	-	-	-	-	-	-	-	-
19	-	-	-	-	21	26.5	31.8	37	42	50	53	58	-	-	-	-	-	-	-	-	-	-	-	-	-	-	-
24	-	-	-	-	-	26.5	31.8	37	42	50	53	58	64	66	74	79	-	-	-	-	-	-	-	-	-	-	-
28	-	-	-	-	-	-	-	-	-	78	92	97	107	117	121	136	146	156	178	185	-	-	-	-	-	-	-
38	-	-	-	-	-	-	-	-	-	78	92	97	107	117	121	136	146	156	178	185	195	204	219	233	-	-	-
42	-	-	-	-	-	-	-	-	-	147	155	170	186	193	217	232	248	271	294	309	325	349	372	387	-	-	-
48	-	-	-	-	-	-	-	-	-	-	-	-	-	283	316	339	361	396	429	452	474	509	542	565	621	-	-
<b>Clamping hub with external taper (K-Hub)</b>																											
14	-	-	-	13.2	25	25	37	52	-	-	-	-	-	-	-	-	-	-	-	-	-	-	-	-	-	-	-
19	-	-	-	-	29	56	89	74	129	146	-	-	-	-	-	-	-	-	-	-	-	-	-	-	-	-	-
24	-	-	-	-	48	71	164	132	234	275	249	327	371	-	-	-	-	-	-	-	-	-	-	-	-	-	-
28	-	-	-	-	-	-	-	-	171	276	204	268	341	381	423	509	466	593	738	-	-	-	-	-	-	-	-
38	-	-	-	-	-	-	-	-	-	287	374	474	529	589	708	653	827	827	947	863	1036	1227	-	-	-	-	-
42	-	-	-	-	-	-	-	-	-	-	-	-	-	532	641	588	750	747	858	802	967	1049	1280	-	-	-	-
48	-	-	-	-	-	-	-	-	-	-	-	-	-	-	857	1004	1248	1262	1429	1362	1609	1880	1710	2150	-	-	-





# TYPE BNN

Hubs with set screws

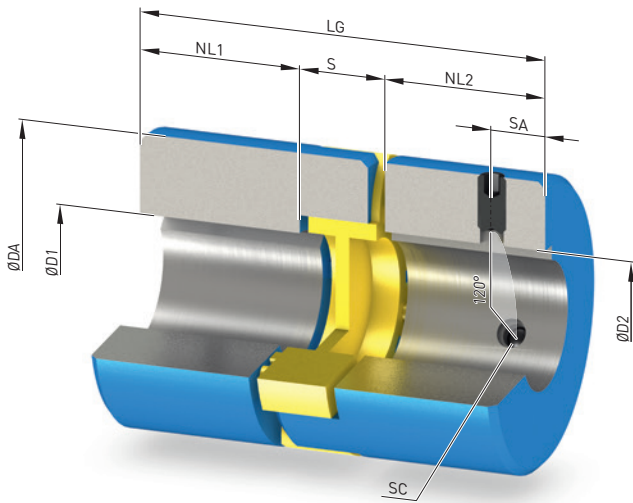

Sizes 5 ... 38

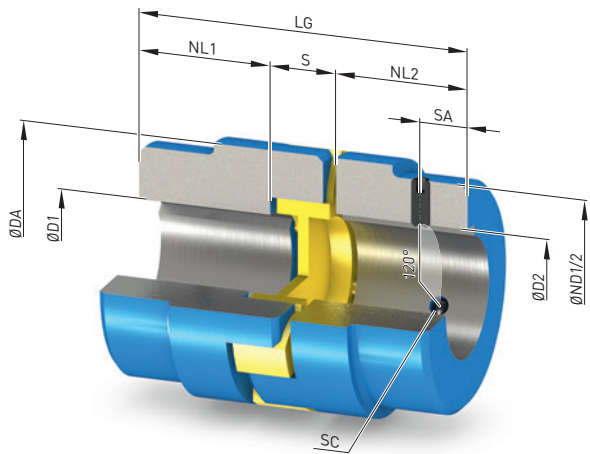
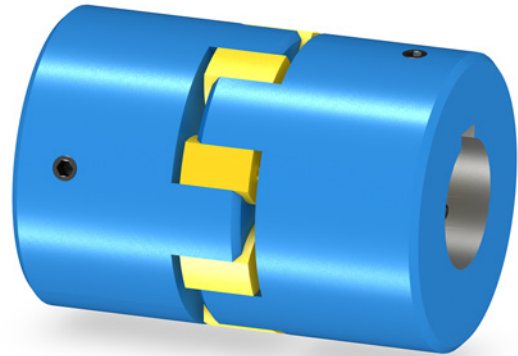

Sizes 42 ... 48

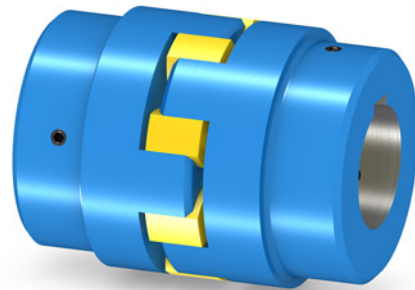

Size	Rated torque		Maximum speed $n_{k \max}$	Dimensions in mm								Screw DIN EN ISO 4027		Mass moment of inertia $J$	Article No. <sup>1)</sup>	Weight $m$
	$T_{KN}$			DA	D1, D2 H7		ND1/ ND2	NL1/ NL2	S	LG	SA	SC	$T_A$			
	Nm	Nm	rpm		min.	max.								Nm	$10^{-6} \cdot \text{kgm}^2$	kg
<b>Hub material aluminum</b>																
5	0.5	0.9	47500	10	2	5	–	5	5	15	2.5	M3	2.5	0.04	2LC0190-0AA99-0AA0	0.003
7	1.2	2	35000	14	3	7	–	7	8	22	3.5	M3	2.5	0.2	2LC0190-1AA99-0AA0	0.007
9	3	5	24000	20	4	10	–	10	10	30	5	M4	5	1.1	2LC0190-2AA99-0AA0	0.018
14	7.5	12.5	16000	30	5	16	–	11	13	35	5	M4	5	6.4	2LC0190-3AA99-0AA0	0.045
19	10	17	12000	40	6	24	–	25	16	66	10	M5	10	37	2LC0190-4AA99-0AA0	0.14
24	35	60	8700	55	8	28	–	30	18	78	10	M5	10	171	2LC0190-5AA99-0AA0	0.36
28	95	160	7400	65	10	38	–	35	20	90	15	M8	15	370	2LC0190-6AA99-0AA0	0.53
38	190	325	6000	80	12	45	–	45	24	114	15	M8	15	1100	2LC0190-7AA99-0AA0	1.1
<b>Hub material steel</b>																
42	265	450	5000	95	14	55	85	50	26	126	20	M8	20	4960	2LC0190-8AA99-0AA0	3.5
48	310	525	4600	105	15	65	95	56	28	140	20	M8	20	9900	2LC0191-0AA99-0AA0	5.3

Configurable variants <sup>1)</sup>

- Cam ring hardness
  - 80 ShoreA
  - 92 ShoreA
  - 98 ShoreA
  - 64 ShoreD

Notes

- Shaft is connected to hub by means of feather key according to DIN 6885-1. The keyway can be optionally omitted and the shaft connected to the hub solely by means of set screws.
- Cam ring made of polyurethane with Shore hardness 92 ShoreA as standard (yellow cam ring).
- For other hardness grades, see page 15/7.
- Weights and mass moments of inertia apply to maximum bore diameters.

Ordering example

- BIPEX-S BNN coupling, size 24
- Part 1: Bore ØD1 20 H7
- Part 2: Bore ØD2 24 H7
- Cam ring with hardness 92 ShoreA

Article No.: 2LC0190-5AA99-0AA0 L0M+M0P

<sup>1)</sup> To identify complete item numbers specifying the available finish boring options and – if necessary – further order options, please use our configurators on [fender.com](http://fender.com).

➤ For online configuration on [fender.com](http://fender.com), click on the item no.

# TYPE BGG

Standard clamping hubs

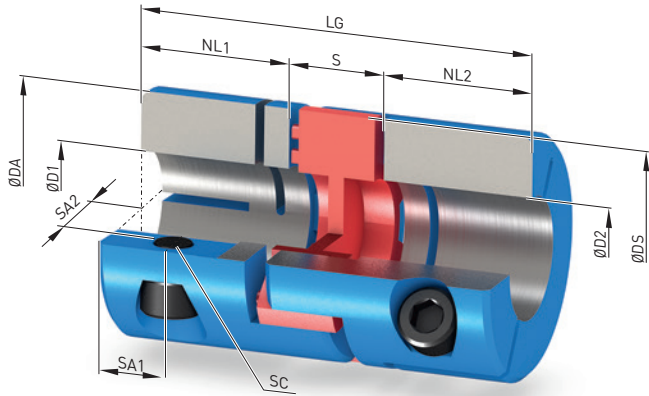

Sizes 5 ... 38

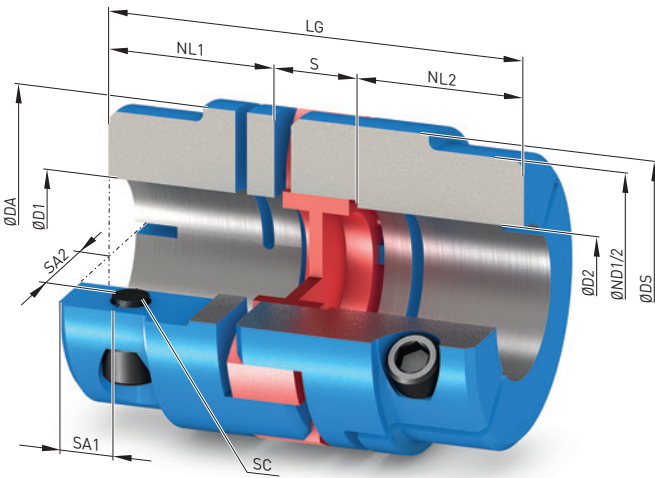
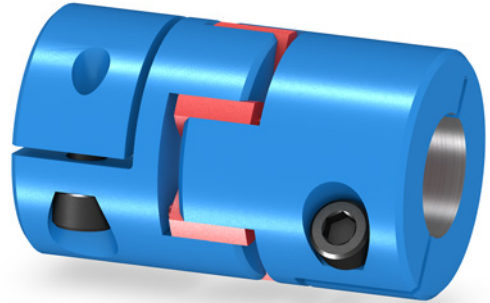

Sizes 42 ... 48

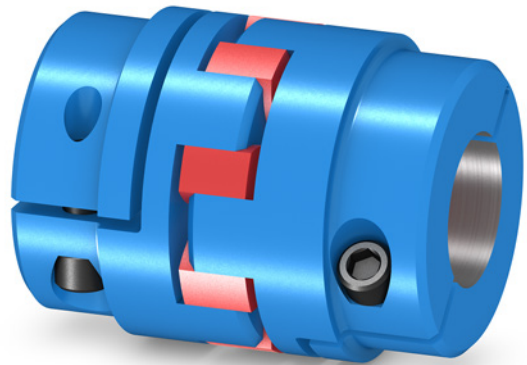

Size	Rated torque		Maximum speed	Dimensions in mm										Screw DIN EN ISO 4762		Mass moment of inertia J	Article No. <sup>1)</sup>	Weight
	$T_{KN}$			$n_{k\ max}$	DA	DS	D1, D2 H7		ND1/ND2	NL1/NL2	S	LG	SA1	SA2	SC			
	Nm	Nm	rpm				min.	max.								Nm	10 <sup>-6</sup> ·kgm <sup>2</sup>	kg
<b>Hub material aluminum</b>																		
5	0.9	0.5	38000	10	11.5	2	4	–	5	5	15	2.5	3.5	M1.6	0.3	0.04	2LC0190-0AB99-0AA0	0.003
7	2	1.2	26000	14	16.5	3	7	–	7	8	22	3.5	5	M2	0.4	0.2	2LC0190-1AB99-0AA0	0.007
9	5	3	18000	20	23.4	5	9	–	10	10	30	5	7.3	M2.5	0.8	1.1	2LC0190-2AB99-0AA0	0.019
14	12.5	7.5	12000	30	32.2	6	16	–	11	13	35	5	11	M3	2	6.3	2LC0190-3AB99-0AA0	0.04
19	17	10	9500	40	45.7	8	24	–	25	16	66	11	14.5	M6	11	37	2LC0190-4AB99-0AA0	0.14
24	60	35	7000	55	57.4	10	28	–	30	18	78	10.5	20	M6	15	165	2LC0190-5AB99-0AA0	0.35
28	160	95	6000	65	72.6	15	38	–	35	20	90	11	24.5	M8	32	390	2LC0190-6AB99-0AA0	0.51
38	325	190	4700	80	83.3	15	45	–	45	24	114	15.5	30	M8	38	1060	2LC0190-7AB99-0AA0	1
<b>Hub material steel</b>																		
42	450	265	4000	95	95	19	50	85	50	26	126	18	32.5	M10	84	4800	2LC0190-8AB99-0AA0	3.6
48	525	310	3500	105	105	25	55	95	56	28	140	21	36	M12	145	8180	2LC0191-0AB99-0AA0	5

Configurable variants <sup>1)</sup>

- Cam ring hardness
  - 80 ShoreA
  - 92 ShoreA
  - 98 ShoreA
  - 64 ShoreD

Notes

- The slotted clamping hub allows a frictionally engaged connection to the input and output shaft.
- A single tightening screw per hub ensures easy assembly.
- The maximum torques that can be transmitted by the clamping connection are listed in the table on page 15/8.
- A keyway according to DIN 6885-1 can be selected additionally as an option.
- Cam ring made of polyurethane with Shore hardness 98 ShoreA as standard (red cam ring).
- For other hardness grades, see page 15/7.
- Weights and mass moments of inertia apply to maximum bore diameters.

Ordering example

- BIPEX-S BGG coupling, size 24
- Part 1: Bore ØD1 20 H7
- Part 2: Bore ØD2 24 H7
- Cam ring with hardness 98 ShoreA

Article No.: 2LC0190-5AB99-0AA0 L0M+M0P

<sup>1)</sup> To identify complete item numbers specifying the available finish boring options and – if necessary – further order options, please use our configurators on [flender.com](http://flender.com).

➤ For online configuration on [flender.com](http://flender.com), click on the item no.

# TYPE BCC

Clamping hubs in compact design

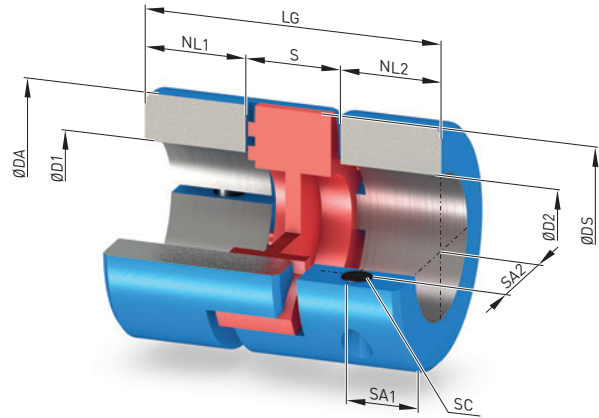

Sizes 5 ... 38

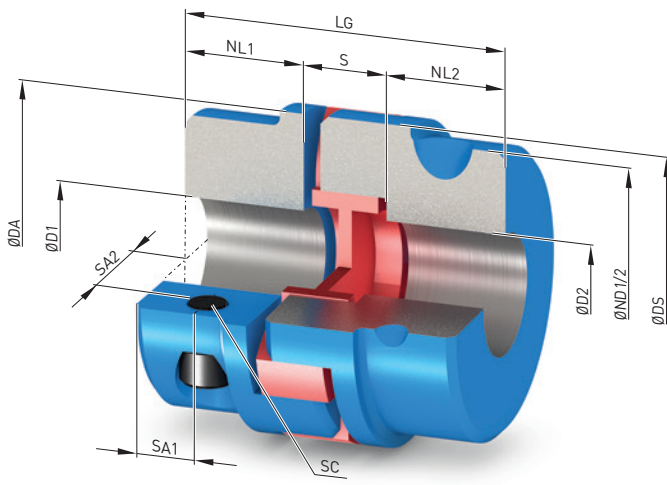
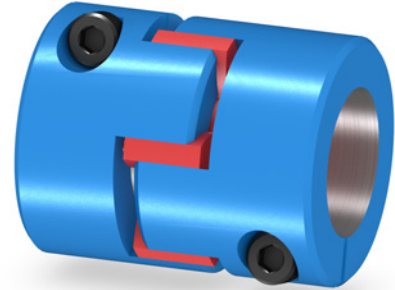

Sizes 42 ... 48

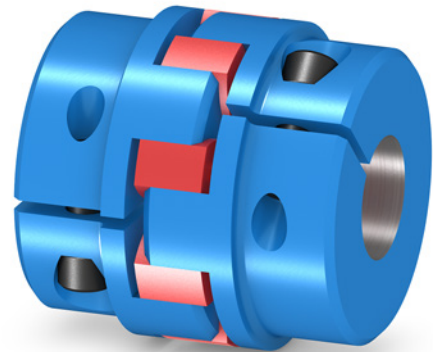

Size	Rated torque		Maximum speed	Dimensions in mm										Screw DIN EN ISO 4762		Mass moment of inertia J	Article No. <sup>1)</sup>	Weight m
	$T_{KN}$			$n_{k\ max}$	DA	DS	D1, D2 H7		ND1/ND2	NL1/NL2	S	LG	SA1	SA2	SC			
	Nm	Nm	rpm				min.	max.								Nm	$10^{-6} \cdot \text{kgm}^2$	kg
<b>Hub material aluminum</b>																		
14	12,5	7,5	12000	30	32,2	6	16	-	11	13	35	5	11	M3	2	6,3	2LC0190-3AF99-0AA0	0,04
19	17	10	9500	40	45,7	10	24	-	17	16	50	8,5	15	M5	10	29	2LC0190-4AF99-0AA0	0,11
24	60	35	7000	55	57,4	12	28	-	20	18	58	10	20	M6	18	123	2LC0190-5AF99-0AA0	0,26
28	160	95	6000	65	72,6	15	35	-	21	20	62	10,5	24,5	M8	43	253	2LC0190-6AF99-0AA0	0,38
38	325	190	4700	80	83,3	16	45	-	31	24	86	15,5	30	M10	84	816	2LC0190-7AF99-0AA0	0,79
<b>Hub material steel</b>																		
42	450	265	4000	95	95	19	50	85	34	26	94	18	32,5	M10	84	3290	2LC0190-8AF99-0AA0	2,5
48	525	310	3500	105	105	25	55	95	40	28	108	21	36	M12	145	5459	2LC0191-0AF99-0AA0	3,3

**Configurable variants <sup>1)</sup>**

- Cam ring hardness **80 ShoreA**  
**92 ShoreA**  
**98 ShoreA**  
**64 ShoreD**

**Notes**

- The slotted clamping hub allows a frictionally engaged connection to the input and output shaft.
- A single tightening screw per hub ensures easy assembly.
- The maximum torques that can be transmitted by the clamping connection are listed in the table on **page 15/8**.
- A keyway according to DIN 6885-1 can be selected additionally as an option.
- Cam ring made of polyurethane with Shore hardness 98 ShoreA as standard (red cam ring).
- For other hardness grades, see **page 15/7**.
- Weights and mass moments of inertia apply to maximum bore diameters.

**Ordering example**

- BIPEX-S BCC coupling, size 24
- Part 1: Bore ØD1 20 H7
- Part 2: Bore ØD2 24 H7
- Cam ring with hardness 98 ShoreA

Article No.: 2LC0190-5AF99-0AA0 L0M+M0P

<sup>1)</sup> To identify complete item numbers specifying the available finish boring options and – if necessary – further order options, please use our configurators on [flender.com](http://flender.com).

↗ For online configuration on [flender.com](http://flender.com), click on the item no.

# TYPE BHH

Half-shell clamping hub

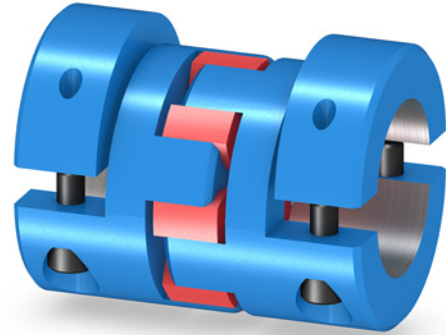
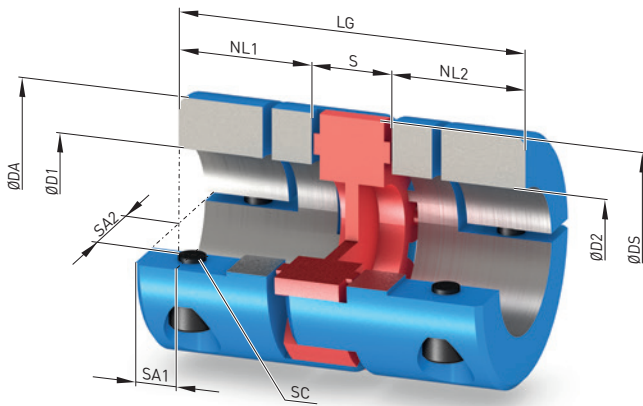

Size	Rated torque		Maximum speed $n_{k \max}$ rpm	Dimensions in mm								Screw DIN EN ISO 4762		Mass moment of inertia $J$ $10^{-6} \cdot \text{kgm}^2$	Article No. <sup>1)</sup>	Weight $m$ kg	
	$T_{KN}$ Nm	92 ShoreA Nm		DA	DS	D1, D2 H7 min.   max.	NL1/ NL2	S	LG	SA1	SA2	SC	$T_A$ Nm				
<b>Hub material aluminum</b>																	
14	12,5	7,5	12000	30	33	6	16	11	13	35	5	11	M4	1,4	5,6	2LC0190-3AC99-0AA0	0,02
19	17	10	9500	40	45	8	23	25	16	66	6	14,5	M5	8	38	2LC0190-4AC99-0AA0	0,15
24	60	35	7000	55	57	10	30	30	18	78	10,5	20	M6	10,5	166	2LC0190-5AC99-0AA0	0,35
28	160	95	6000	65	70	15	38	35	20	90	11	24,5	M8	25	370	2LC0190-6AC99-0AA0	0,53
38	325	190	4700	80	83	15	48	45	24	114	15,5	30	M8	25	1040	2LC0190-7AC99-0AA0	0,98
<b>Hub material steel</b>																	
42	450	265	4000	95	95	19	50	50	26	126	18	32,5	M10	69	5970	2LC0190-8AC99-0AA0	4,1
48	525	310	3500	105	105	25	55	56	28	140	15	40	M12	120	9830	2LC0191-0AC99-0AA0	5,6

## Configurable variants <sup>1)</sup>

- Cam ring hardness
  - 80 ShoreA
  - 92 ShoreA
  - 98 ShoreA
  - 64 ShoreD

## Notes

- It is possible to radially assemble and dismantle the hub version with half-shells without moving the connected units.
- The maximum torques that can be transmitted by the clamping connection are listed in the table on page 15/8.
- A keyway according to DIN 6885-1 can be selected additionally as an option.
- Cam ring made of polyurethane with Shore hardness 98 ShoreA as standard (red cam ring).
- For other hardness grades, see page 15/7.
- Weights and mass moments of inertia apply to maximum bore diameters.

## Ordering example

- BIPEX-S BHH coupling, size 24
- Part 1: Bore ØD1 20 H7
- Part 2: Bore ØD2 24 H7
- Cam ring with hardness 98 ShoreA

Article No.: 2LC0190-5AC99-0AA0 L0M+M0P

<sup>1)</sup> To identify complete item numbers specifying the available finish boring options and – if necessary – further order options, please use our configurators on flender.com.

↗ For online configuration on flender.com, click on the item no.



# TYPE BKK

Clamping hubs with external taper

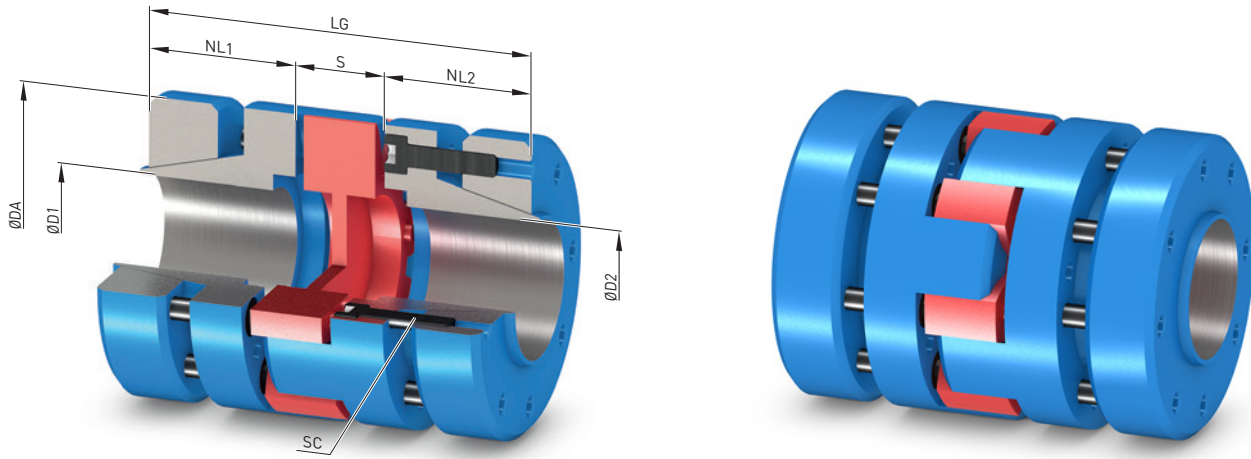

Size	Rated torque		Maximum speed $n_{k \max}$	Dimensions in mm					Screw DIN EN ISO 4762		Mass moment of inertia $J$	Article No. <sup>1)</sup>	Weight $m$	
	$T_{KN}$			DA	D1, D2 H7	NL1/ NL2	S	LG	SC	$T_A$				
	Nm	Nm	rpm	min.	max.				Nm	$10^{-6} \cdot \text{kgm}^2$		kg		
Hub material aluminum														
14	12,5	7,5	25000	30	5	14	18,5	13	50	M3	1,3	18	2LC0190-3AD99-0AA0	0,11
19	17	10	18500	40	10	20	25	15	65	M4	2,9	57	2LC0190-4AD99-0AA0	0,23
24	60	35	13900	55	10	25	30	18	78	M5	6	268	2LC0190-5AD99-0AA0	0,57
28	160	95	11800	65	15	36	35	20	90	M5	6	610	2LC0190-6AD99-0AA0	0,86
38	325	190	9600	80	20	48	45	24	114	M6	10	1690	2LC0190-7AD99-0AA0	1,5
Hub material steel														
42	450	265	8000	95	28	50	50	26	126	M8	35	5880	2LC0190-8AD99-0AA0	4
48	525	310	7100	105	30	55	56	28	140	M10	69	9600	2LC0191-0AD99-0AA0	5,4

## Configurable variants <sup>1)</sup>

- Cam ring hardness
  - 80 ShoreA
  - 92 ShoreA
  - 98 ShoreA
  - 64 ShoreD

## Notes

- The clamping hubs with external taper are the ideal solution for high-speed and highly dynamic applications. The clamping ring is made of steel.
- The maximum torques that can be transmitted by the clamping connection are listed in the table on [page 15/8](#).
- Cam ring made of polyurethane with Shore hardness 98 ShoreA as standard (red cam ring).
- For other hardness grades, see [page 15/7](#).
- Sizes 14 to 48 are also available on request as a light-weight version with hubs and clamping rings made of aluminum [type designation BKK-L].
- Weights and mass moments of inertia apply to maximum bore diameters.

## Ordering example

- BIPEX-S BKK coupling, size 24
- Part 1: Bore ØD1 20 H7
- Part 2: Bore ØD2 24 H7
- Cam ring with hardness 98 ShoreA

Article No.: 2LC0190-5AD99-0AA0 L0M+M0P

<sup>1)</sup> To identify complete item numbers specifying the available finish boring options and – if necessary – further order options, please use our configurators on [flender.com](http://flender.com).

➤ For online configuration on [flender.com](http://flender.com), click on the item no.

# TYPE BCS

Compact clamping hubs and expanding hub

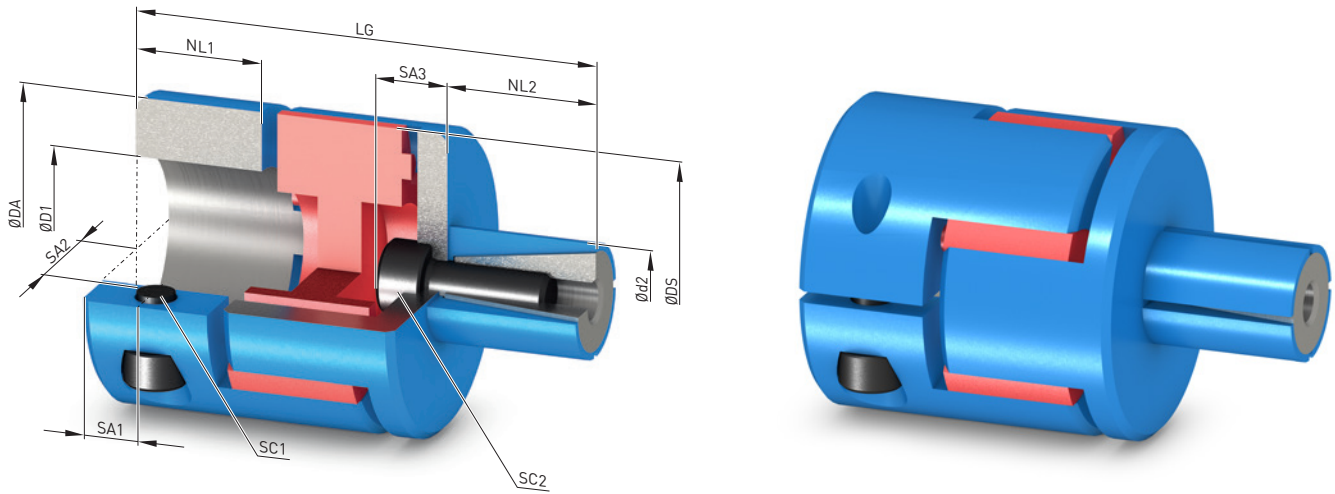

Size	Rated torque		Maximum speed $n_{k,max}$	Dimensions in mm									Screw DIN EN ISO 4762		Screw DIN EN ISO 4207		Mass moment of inertia $J$	Article No. <sup>1)</sup>	Weight $m$			
	$T_{KN}$	92 ShoreA		DA	DS	D1 H7	d2 h7	NL1	NL2	LG	SA1	SA2	SA3	SC1	$T_A$	SC2				$T_A$	10 <sup>-6</sup> · kgm <sup>2</sup>	kg
<b>Hub material aluminum</b>																						
9	5	3	18000	20	23,4	5	9	10	16	10	11	40	5	7,3	9	M2,5	0,75	M4	8	1	2LC0190-2AE99-0AA0	0,03
14	12,5	7,5	12000	30	32,2	6	16	13	25	11	12,5	42,5	5	11	7	M3	2	M5	9	7	2LC0190-3AE99-0AA0	0,06
19	17	10	9500	40	45,7	10	24	14	30	17	20	61	8,5	14,5	8	M5	15	M6	15	28	2LC0190-4AE99-0AA0	0,13
24	60	35	7000	55	57,4	12	28	23	38	20	30	76	10	20	12	M6	15	M8	35	113	2LC0190-5AE99-0AA0	0,33
28	160	95	6000	65	72,6	15	35	26	42	21	36	85	10,5	24,5	13	M8	35	M10	70	222	2LC0190-6AE99-0AA0	0,5
38	325	190	4700	80	83,3	16	45	38	60	31	45	113	15,5	30	17	M8	35	M12	120	800	2LC0190-7AE99-0AA0	1,1

## Configurable variants <sup>1)</sup>

- Cam ring hardness
  - 80 ShoreA
  - 92 ShoreA
  - 98 ShoreA
  - 64 ShoreD

## Notes

- A hollow shaft can be connected to the expanding hub.
- The bore for connecting the expanding hub must have tolerance H7.
- Cam ring made of polyurethane with Shore hardness 98 ShoreA as standard (red cam ring).
- For other hardness grades, see page 15/7.
- Weights and mass moments of inertia apply to maximum bore diameters.

## Ordering example

- BIPEX-S BCS coupling, size 24
- Part 1: Bore ØD1 20 H7
- Part 2: Shaft Ød2 24 h7
- Cam ring with hardness 98 ShoreA

Article No.: 2LC0190-5AE99-0AA0 L0M+M0P

<sup>1)</sup> To identify complete item numbers specifying the available finish boring options and – if necessary – further order options, please use our configurators on flender.com.

↗ For online configuration on flender.com, click on the item no.

# TYPE BHH-W

Drive shaft with half-shell clamping hubs

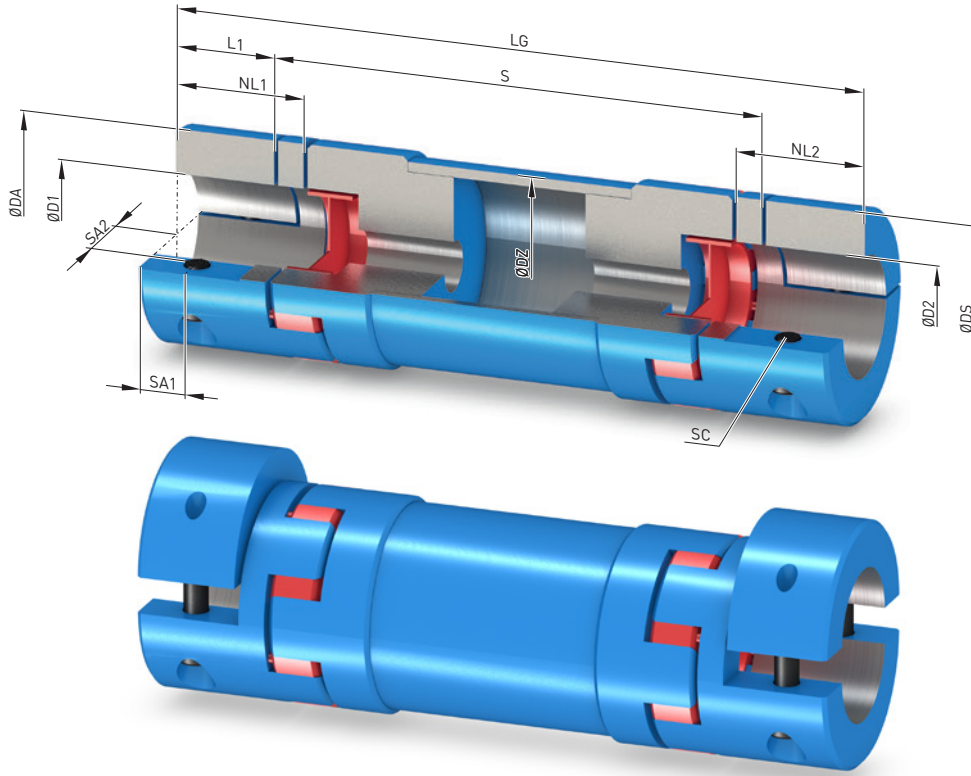

Size	Rated torque $T_{KN}$ Nm	Maximum speed $n_{k\ max}$ rpm	Dimensions in mm											Screw DIN EN ISO 4762		Mass moment of inertia <sup>2)</sup> J 10 <sup>-6</sup> ·kgm <sup>2</sup>	Article No. <sup>1)</sup>	Weight m kg	
			DA	DS	D1, D2 H7		DZ	NL1/ NL2	L1	LG	SA1	SA2	SC	T <sub>A</sub>					
<b>Hub material Aluminium</b>																			
14	12,5	1500	30	33	6	16	30	11	9	85	3000	5	11	M4	3	79	2LC0190-3AH99-0AZ0	0,54	
19	17	1500	40	45	8	23	40	25	13,4	135	3000	6	15	M5	5,9	151	2LC0190-4AH99-0AZ0	0,58	
24	60	1500	55	57	10	30	50	30	21	165	3000	10,5	20	M6	15	2250	2LC0190-5AH99-0AZ0	3,4	
28	160	1500	65	70	15	38	60	35	23,5	205	3000	11	24,5	M8	32	2510	2LC0190-6AH99-0AZ0	3,5	
38	325	1500	80	83	15	48	75	45	33	250	3000	15,5	30	M8	38	8360	2LC0190-7AH99-0AZ0	7,8	
<b>Hub material Stahl</b>																			
42	450	1500	95	95	19	50	90	50	35	265	3000	18	32,5	M10	84	1780	2LC0190-8AH99-0AZ0	11,8	
48	525	1500	105	105	25	55	110	56	32,5	285	3000	15	40	M12	145	21150	2LC0191-0AH99-0AZ0	15,3	

### Configurable variants<sup>1)</sup>

- Cam ring hardness **98 ShoreA**  
**64 ShoreD**

### Notes

- It is possible to radially assemble and dismantle the hub version with half-shells without moving the connected units. It must be noted that the total length LG is obtained with shaft distance  $S + 2 \times L1$ .
- The intermediate tubes in the standard version are made of aluminum. Tubes made of carbon-fiber-reinforced plastic (CFRP) are also available as an option.
- Weights and mass moments of inertia apply to maximum bore diameters and a shaft distance  $S = 1000$  mm.

### Ordering example

- BIPEX-S BHH-W coupling, size 24  
Shaft distance  $S = 1000$  mm  
Total length  $LG = 1042$  mm
- Part 1: Bore  $\text{ØD1 } 20$  H7
- Part 2: Bore  $\text{ØD2 } 24$  H7
- Cam ring with hardness 98 ShoreA

Article No.: **2LC0190-5AH99-0AZ0 L0M+M0P+Q0Y**  
Plain text for Q0Y:  $S = 1000$  mm

<sup>1)</sup> To identify complete item numbers specifying the available finish boring options and – if necessary – further order options, please use our configurators on [flender.com](http://flender.com).

<sup>2)</sup> for DBSE = 1000 mm

↗ For online configuration on [flender.com](http://flender.com), click on the item no.



# APPENDIX

<b>Fits</b>	<b>A/2</b>
Fitting recommendations	A/2
Deviation table to DIN ISO 286	A/2
Cylindrical shaft ends, extract from DIN 748 Part 1 (long)	A/3
Central holes according to DIN 332 Part 2	A/3
<b>Parallel key connections to DIN 6885-1</b>	<b>A/4</b>
<b>Related catalogs</b>	<b>A/6</b>
<b>Suitable gear solutions</b>	<b>A/8</b>
<b>The perfect coupling</b>	<b>A/10</b>
<b>Individual solutions</b>	<b>A/12</b>
<b>Flender Services</b>	<b>A/16</b>

# FITS

## Fitting recommendations

For many applications, the fit assignment m6/H7 is especially suitable.

Description	Application	Shaft tolerance	Bore tolerance
Facile sliding fit	For steel or aluminum hubs Preferred for SIPEX and BIPEX-S coupling series	g6	H7
		h7	H7
		k6	F7
		m6	F7
Sliding fit with parallel key connection not suitable for reversing operation	For steel and cast hubs	j6	H7
		h6	J7
Press fit with parallel key connection not suitable for reversing operation	For steel and cast hubs	h6	K7
		k6	H7
Interference fit with parallel key connection suitable for reversing operation	For steel and cast hubs  Only for steel hubs Preferred for ZAPEX and ARPEX coupling series	m6	H7
		n6	H7
		h6	M7
		h6	P7
		k6	M7
		m6	K7
		n6	J7
		p6	H7
Shrink fit connection without parallel key	Only for steel hubs The permitted hub tension must be urgently checked.	s6	F7
		u6	H6
		v6	H6
		x6	H6

## Deviation table to DIN ISO 286 for above-mentioned fits for bore diameters from 10 mm to 250 mm

Bore diameter above	up to	Deviations in µm							Shaft					
		Bore							h6	j6	k6	m6	n6	p6
		F7	H7	J7	K7	M7	P7							
10	18	+34	+18	+10	+6	0	-11	0	+8	+12	+18	+23	+29	
		+16	0	-8	-12	-18	-29	-11	-3	+1	+7	+12	+18	
18	30	+41	+21	+12	+6	0	-14	0	+9	+15	+21	+28	+35	
		+20	0	-9	-15	-21	-35	-13	-4	+2	+8	+15	+22	
30	50	+50	+25	+14	+7	0	-17	0	+11	+18	+25	+33	+42	
		+25	0	-11	-18	-25	-42	-16	-5	+2	+9	+17	+26	
50	80	+60	+30	+18	+9	0	-21	0	+12	+21	+30	+39	+51	
		+30	0	-12	-21	-30	-51	-19	-7	+2	+11	+20	+32	
80	120	+71	+35	+22	+10	0	-24	0	+13	+25	+35	+45	+59	
		+36	0	-13	-25	-35	-59	-22	-9	+3	+13	+23	+37	
120	180	+83	+40	+26	+12	0	-28	0	+14	+28	+40	+52	+68	
		+43	0	-14	-28	-40	-68	-25	-11	+3	+15	+27	+43	
180	250	+96	+46	+30	+13	0	-33	0	+16	+33	+46	+60	+79	
		+50	0	-16	-33	-46	-79	-29	-13	+4	+17	+31	+50	

A

### Cylindrical shaft ends, extract from DIN 748 Part 1 (long)

	Diameter in mm																					
	24	25	28	30	32	35	38	40	42	45	48	50	55	60	65	70	75	80	85	90	95	100
ISO tolerance zone	k6												m6									
End length in mm	50	60	80					110						140				170				210

### Central holes according to DIN 332 Part 2

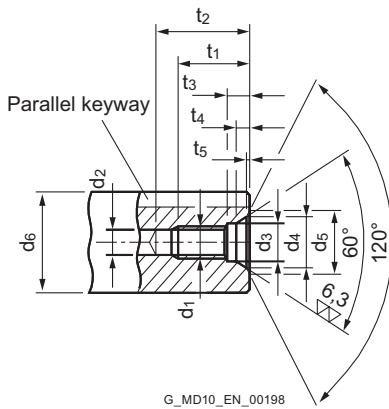

Form DS (with thread) DIN 332/2

Recommended diameter ranges $d_6$ <sup>1)</sup>		DS form dimensions									
above	up to	$d_1$	$d_2$ <sup>2)</sup>	$d_3$	$d_4$	$d_5$	$t_1$ <sub>+2</sub>	$t_2$ <sub>min.</sub>	$t_3$ <sub>+1</sub>	$t_4$ <sub>approx.</sub>	$t_5$ <sub>approx.</sub>
7	10	M3	2.5	3.2	5.3	5.8	9	12	2.6	1.8	0.2
10	13	M4	3.3	4.3	6.7	7.4	10	14	3.2	2.1	0.3
13	16	M5	4.2	5.3	8.1	8.8	12.5	17	4	2.4	0.3
16	21	M6	5	6.4	9.6	10.5	16	21	5	2.8	0.4
21	24	M8	6.8	8.4	12.2	13.2	19	25	6	3.3	0.4
24	30	M10	8.5	10.5	14.9	16.3	22	30	7.5	3.8	0.6
30	38	M12	10.2	13	18.1	19.8	28	37	9.5	4.4	0.7
38	50	M16	14	17	23	25.3	36	45	12	5.2	1.0
50	85	M20	17.5	21	28.4	31.3	42	53	15	6.4	1.3
85	130	M24	21	25	34.2	38	50	63	18	8	1.6
130	225	M30 <sup>3)</sup>	26.5	31	40.2	44.6	60	77	22	8	1.9
225	320	M36 <sup>3)</sup>	32	37	49.7	55	74	93	22	11	2.3
320	500	M42 <sup>3)</sup>	37.5	43	60.3	66.6	84	105	26	15	2.7

<sup>1)</sup> Diameter refers to the finished workpiece

<sup>2)</sup> Tap hole drill diameter according to DIN 336 Part 1

<sup>3)</sup> Dimensions not acc. to DIN 332 Part 2

# PARALLEL KEY CONNECTIONS TO DIN 6885-1

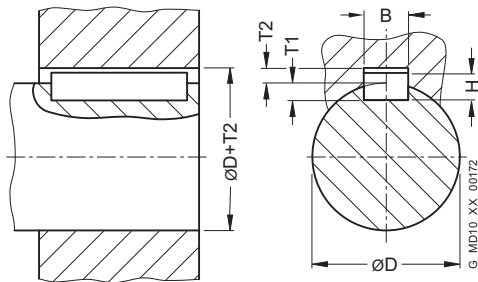

For moderate operating conditions, the hub keyway tolerance JS9 is recommended.

In harsh operating conditions or during reversing operation, the keyway width tolerance P9 must be preferred.

With two parallel keyways, the keyway width tolerance JS9 should be specified in order to simplify the assembly.

The shaft keyway width has to be specified with the tolerance N9.

Diameter above D mm	up to mm	Keyway width B mm	Parallel key height H mm	Shaft keyway depth T1 mm	Hub keyway depth T2 mm	Deviation for shaft and hub keyway depth mm	Deviation table for keyway width B	
							JS9 $\mu\text{m}$	P9 $\mu\text{m}$
	10	3	3	1.8	1.4	+0.1	+12.5 -12.5	-6 -31
10	12	4	4	2.5	1.8	+0.1	+15 -15	-12 -42
12	17	5	5	3	2.3	+0.1	+15 -15	-12 -42
17	22	6	6	3.5	2.8	+0.1	+15 -15	-12 -42
22	30	8	7	4	3.3	+0.2	+18 -18	-15 -51
30	38	10	8	5	3.3	+0.2	+18 -18	-15 -51
38	44	12	8	5	3.3	+0.2	+21.5 -21.5	-18 -61
44	50	14	9	5.5	3.8	+0.2	+21.5 -21.5	-18 -61
50	58	16	10	6	4.3	+0.2	+21.5 -21.5	-18 -61
58	65	18	11	7	4.4	+0.2	+21.5 -21.5	-18 -61
65	75	20	12	7.5	4.9	+0.2	+26 -26	-22 -74
75	85	22	14	9	5.4	+0.2	+26 -26	-22 -74
85	95	25	14	9	5.4	+0.2	+26 -26	-22 -74



Diameter		Keyway width B mm	Parallel key height H mm	Shaft keyway depth		Hub keyway depth T2 mm	Deviation for shaft and hub keyway depth mm	Deviation table for keyway width B	
above D mm	up to mm			T1 mm	T2 mm			JS9 µm	P9 µm
95	110	28	16	10	6.4	+0.2	+26	-22	
							-26	-74	
110	130	32	18	11	7.4	+0.2	+31	-26	
							-31	-88	
130	150	36	20	12	8.4	+0.3	+31	-26	
							-31	-88	
150	170	40	22	13	9.4	+0.3	+31	-26	
							-31	-88	
170	200	45	25	15	10.4	+0.3	+31	-26	
							-31	-88	
200	230	50	28	17	11.4	+0.3	+31	-26	
							-31	-88	
230	260	56	32	20	12.4	+0.3	+37	-32	
							-37	-106	
260	290	63	32	20	12.4	+0.3	+37	-32	
							-37	-106	
290	330	70	36	22	14.4	+0.3	+37	-32	
							-37	-106	
330	380	80	40	25	15.4	+0.3	+37	-32	
							-37	-106	
380	440	90	45	28	17.4	+0.3	+43.5	-37	
							-43.5	-124	
440	500	100	50	31	19.4	+0.3	+43.5	-37	
							-43.5	-124	

# RELATED CATALOGS

## Torsionally Rigid Couplings

FLE 10.1  
FLEX-C10001-00-7600



## Flexible Couplings

FLE 10.2  
FLEX-C10002-00-7600



## Highly Flexible Couplings

FLE 10.3  
FLEX-C10003-00-7600



## Fluid Couplings

FLE 10.4  
FLEX-C10004-00-7600



## ARPEX

High Performance Couplings  
FLE 10.5  
FLEX-C10120-00-7600



## SIPEX und BIPEX-S

Backlash-free couplings  
FLE 10.6  
FLEX-C10121-00-7600



## ARPEX

Safety couplings  
FLE 10.7  
FLEX-C10122-00-7600



## FASTEX

Clamping elements  
FLE 10.8  
FLEX-C10152-00-7600



**FLENDER SIP**

Standard Industrial Planetary Gear Units

MD 31.1

PDMD-C10154-00

**FLENDER CHG**

Helical Gear Units

MD 20.10

PDMD-C10155-00

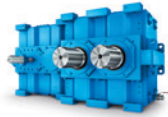
**Gear units**

Fast Track

MD 20.12

PDMD-C10156-00

**Bucket Elevator Drives**

MD 20.2

PDMD-C10157-00

**PLANUREX 3**

Planetary Gear Units

FLE 20.3

FLEX-C10052-00-7600

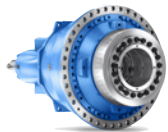
**Paper Machine Drives**

MD 20.5

PDMD-C10159-00

**Conveyor Belt Drives**

MD 20.6

PDMD-C10160-00

**Marine Reduction Gearboxes**

MD 20.7

PDMD-C10161-00

**DUORED 2**

Helical Gear Units, Load-sharing

MD 20.8

PDMD-C10162-00

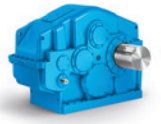
**Pinion Drive for Tube Mills**

MD 20.9

PDMD-C10163-00





## THE RIGHT GEAR UNIT SOLUTION FOR ANY REQUIREMENT

We provide helical and planetary gear units made up of standard modules or as a complete application solution.

Helical and planetary gear units from Flender are modern drive solutions that satisfy the most varying and extreme demands, day after day and year after year. For decades, plant operators have been achieving high system reliability and low lifecycle costs in every conceivable industry with our helical gear units.

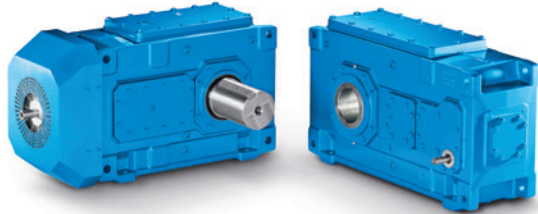

### Helical and bevel helical gear units

Flender helical and bevel helical gear units are by far the most comprehensive range of industrial gear units in the world. It ranges from a multi-faceted universal gear unit portfolio and application-specific gear units to customer-specific solutions.

**Rated torque: 3,300 Nm ... 1,400,000 Nm**

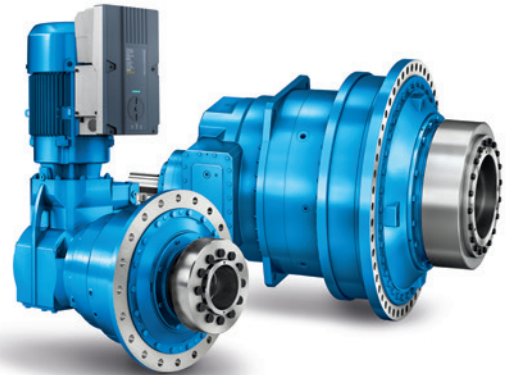

### Planetary Gear Units

With Flender planetary gear units, we provide a range of durable, reliable and finely graduated gear unit solutions. The series wins customers over due to its highly integrated planetary geared motor and maximum conformity with all international motor standards. It also brings quality and performance in a good ratio of lifecycle costs to price.

**Rated torque: 10,000 Nm ... 5,450,000 Nm**

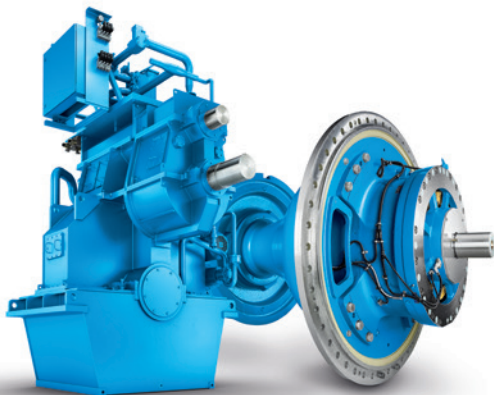

### Application-specific gear units

With application-specific gear units, Flender provides by far the most application solutions and thus covers nearly every drive-related need from hundreds of applications in industry and the acquisition of raw materials.

**Rated torque: up to 10,000,000 Nm**



### Customer-specific designs

Our experts are available at any time for special requirements during the development of new products. From designing and simulating complex drive solutions to implementing them, we work together with you to resolve multi-layered tasks.



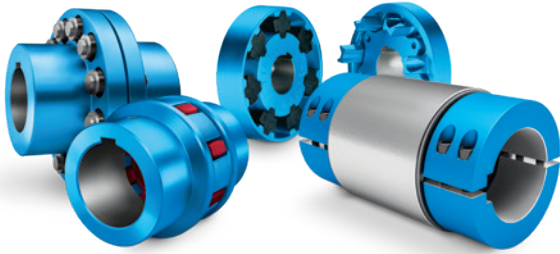

### Flexible couplings

Our elastic couplings are pluggable and easy to install. The elastomer element equalizes the shaft offset and absorbs impacts from the motor or driven machine.

**Nominal output torque: 12 Nm ... 1,690,000 Nm**



### Torsionally rigid couplings

Our compact steel couplings provide extremely precise transmission of high torques, especially in harsh operating conditions and extreme temperatures.

**Nominal output torque: 92 Nm ... 7,200,000 Nm**



### Hydrodynamic couplings

Soft start, overload protection, torsional vibration damping – FLUDEX® fluid couplings allow the torque-limited approach and have very little slippage at rated load.

**Power: 1.2 kW ... 2,500 kW**



### Highly-flexible couplings

Highly flexible couplings are well-suited for connecting machines that operate asymmetrically. They are preferred for use in systems that are periodically operated.

**Nominal output torque: 24 Nm ... 90,000 Nm**

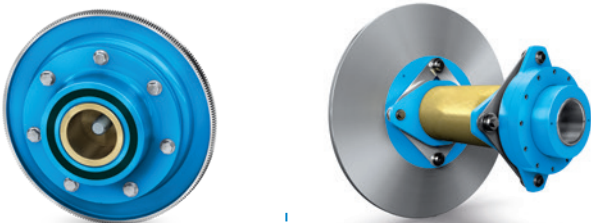

### Application-specific couplings

Flender offers a variety of application-specific couplings for rail vehicles and use in wind energy generation.

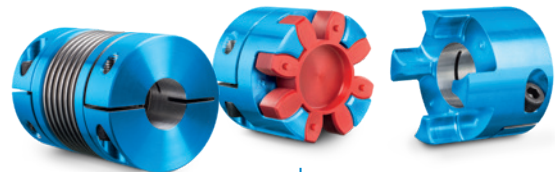

### Backlash-free couplings

Our couplings act as a modular interface between the motor and the work machine to ensure reliable, backlash-free power transmission in servodrives and positioning drives.

**Nominal output torque: 0.1 Nm ... 5,000 Nm**

Flender's system competence turns first-class components into systems with tangible added value. Drive systems from Flender ensure maximum productivity, energy efficiency and reliability in any automation environment.

### Consultation

Our customers use our interdisciplinary know-how, our application competence, our innovation strength and, last but not least, our experience to find the right drive system for their individual requirements.

Reduced engineering time, lower costs



### Integrated drive portfolio

We not only provide gear units and couplings, but also have the competence in electrical drive technology that enables us to offer the entire drive train – perfectly integrated, with optimal interaction between all components, as a standard or individual solution.

Fewer interface risks, more efficiency



# INDIVIDUAL SOLUTIONS.

We have the right solution for you, even if your requirements are special. We no longer have to newly develop every special solution. Many solutions are already available.

At [flender.com](https://www.flender.com), we provide application-specific solutions for your special requirements.

Use our online configurator, which allows you to create tailored product combinations.

## Flender service

From diagnostics and support, replacement part and repair services, all the way to maintenance and retrofit services – the Flender service portfolio creates individual solutions, fully and completely tailored to the needs of our customers. In this way, a gear unit remains an original Flender gear unit.

Increased system availability, reduced lifecycle costs

## DIAGNOSTEX

Ensuring the process stability requires status-oriented maintenance of the drive train. With DIAGNOSTEX®, sensors measure deviations of our gear units from the target status. These can be analyzed and evaluated in terms of maximized system availability.

Industrie 4.0, reduced costs

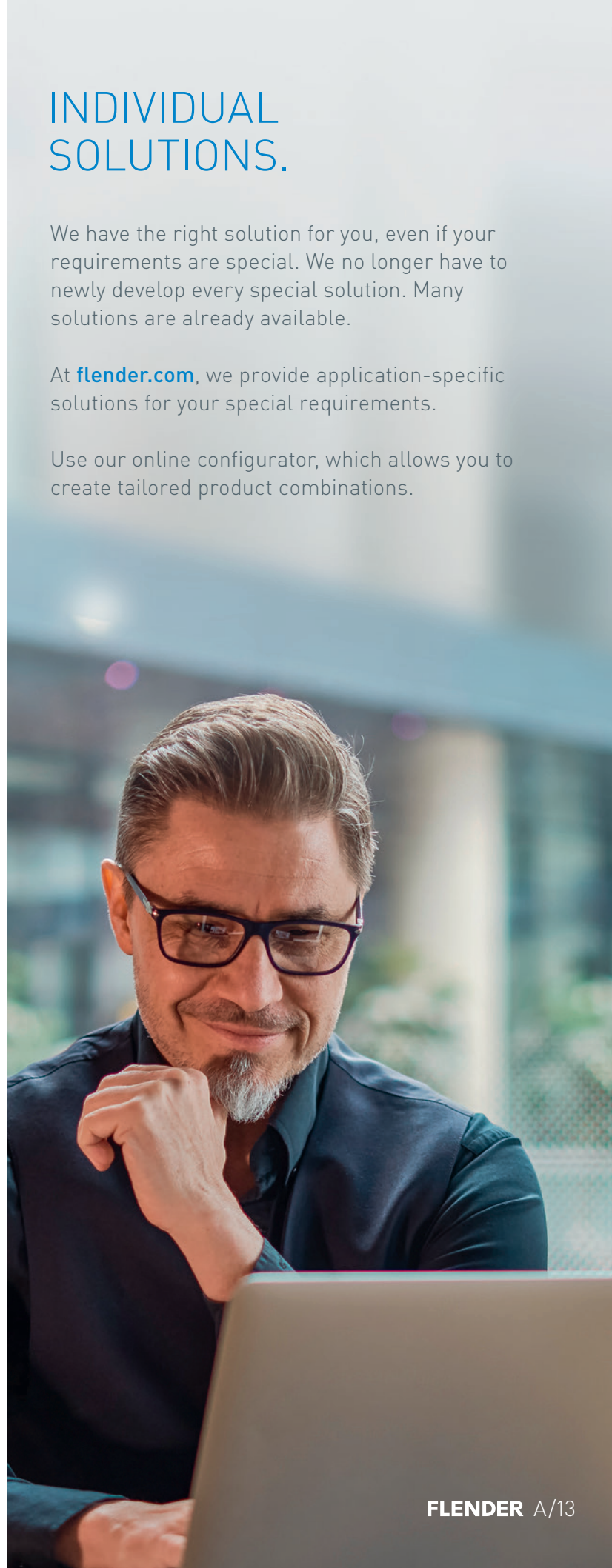

# GREAT EXPERTISE IN YOUR INDUSTRY TOO.

Each industry has its own conditions. Every application has its own specific requirements. We are looking forward to meeting your challenges.

We probably already have the right solution at hand. Here are a few examples:



Minerals and mining

**Requirement:**  
Perfectly coordinated drive system



Cement

**Requirement:**  
Low maintenance effort and cost,  
sealing due to dirt in surroundings



Plastics and rubber

**Requirement:**  
Absorption of high axial forces,  
suitability for explosion protection

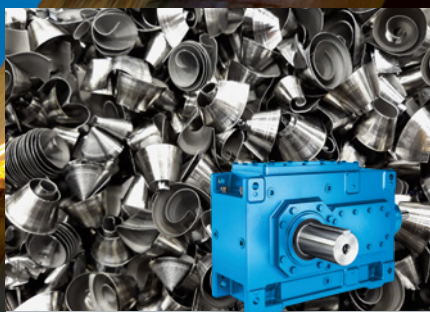

Environmental and recycling

**Requirement:**  
Highest possible reliability, rugged  
design



Pulp and paper

**Requirement:**  
Suitability for centrally located  
lubrication



Industrial cranes

**Requirement:**  
Quick availability, version with  
double drive shaft



### Chemicals

**Requirement:**  
Absorption of forces from the manufacturing process



### Power generation

**Requirement:**  
Effective cooling, speed adjustment for motor to fan



### Metals

**Requirement:**  
Harsh working conditions, high peak loads



### Harbor cranes

**Requirement:**  
Specific axle clearance, frequent start-up



### Oil and gas

**Requirement:**  
Flexible adaptation to speed requirements



### Water and wastewater

**Requirement:**  
Absorption of external forces, oil-retaining pipe required



## AN ORIGINAL FOR THE LONG TERM WITH ORIGINAL FLENDER SERVICES

Ever increasing requirements make it more and more important for industrial plants to work with maximum productivity and efficiency. Flender Services give companies a decisive advantage over the competition in industry, the acquisition of raw materials and energy production. In view of the high cost pressure, increasing energy prices and stricter and stricter environmental stipulations, our services are becoming a decisive factor to success over the competition.

Enjoy the support of our service experts, from planning, development and operation to the modernization of your plant and benefit from our experience and in-depth know-how of your application – in more than 100 countries, seven days a week, 24 hours a day.

Reduce standstills, minimize downtimes due to failure, and increase the productivity, flexibility and cost efficiency of your plant.

# OUR OFFER FOR GEAR UNITS AND COUPLINGS AT A GLANCE.

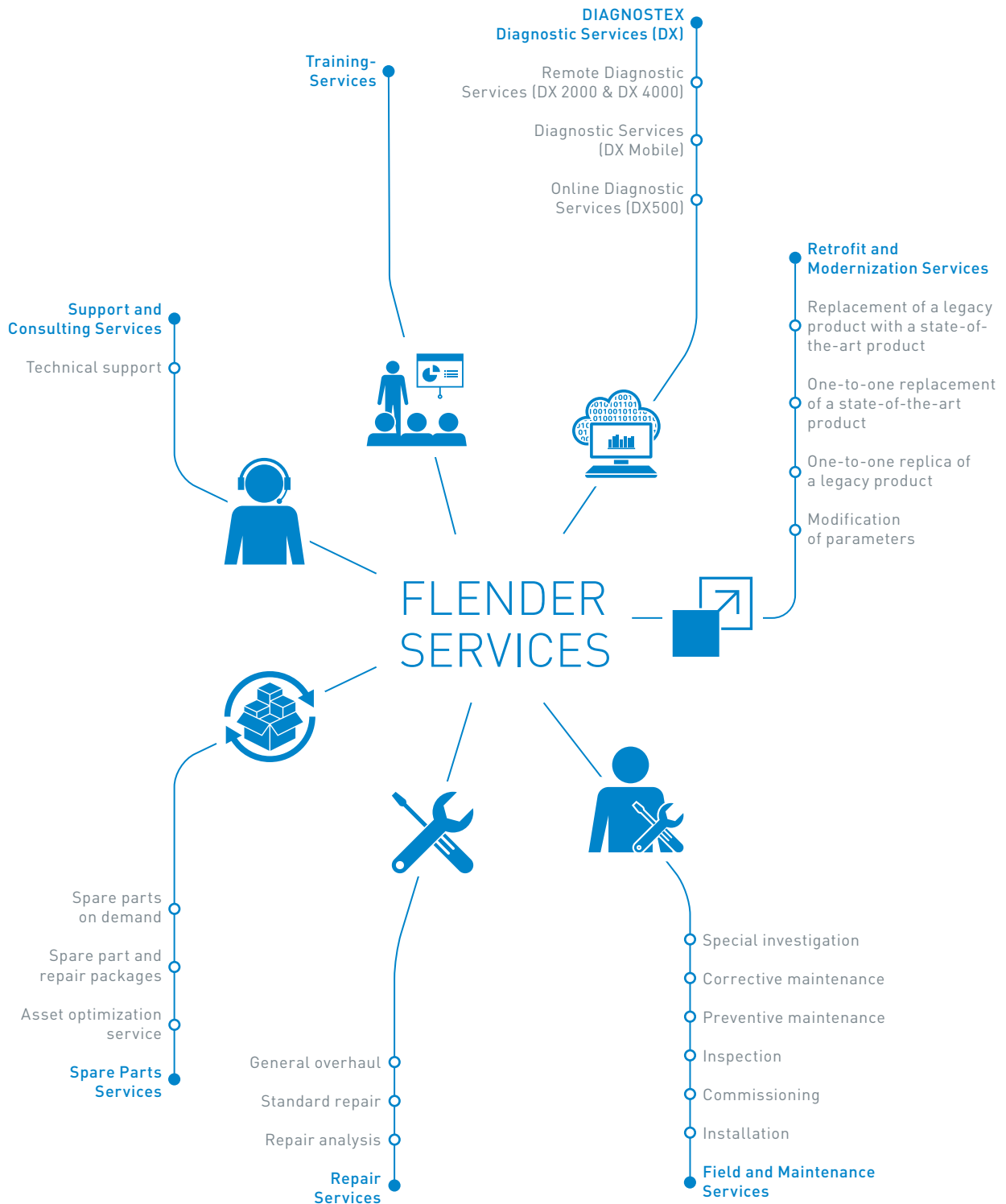





# FLENDER COUPLINGS CATALOG **FLE 10** EDITION 2023 EN

---

**flender.com**

---

Further information on the subject of couplings:

**flender.com/couplings**

---

Further information on the subject of applications:

**flender.com/application-specific-gear-unit**

---

For further information on gears:

**flender.com/gearunits**

---

Further information on the subject of service:

**flender.com/services**

---

## **Flender GmbH**

Alfred-Flender-Straße 77

46395 Bocholt

Germany

Article no.: FLEX-C10000-00-7600

The information given in this product catalog includes descriptions and performance features that in specific applications do not always apply in the form described or may change through further-development of the products. The desired performance features are binding only if they are expressly agreed on conclusion of contract. Subject to availability for delivery and to technical changes.

**flender.com**